

Power capacitors



Power capacitors for reactive current compensation in single-phase and 3-phase versions, developed for the highest requirements. Apart from a long operating life and high current and voltage load capacity, safety in case of overload (all-pole overpressure disconnecter) is a crucial advantage of the compact dry technology components. Other features are good heat dissipation, low self-heating as well as reliable performance at high ambient temperatures.



About us

Basics

Reactive power controllers

Power capacitors

Filter circuit reactors

Capacitor contactors and thyristor switches

KBR system

multicond

rated voltage U_n	280, 440, 480, 525, 690 or 800 V
rated frequency f	50/60 Hz



Power capacitor for reactive current compensation

- Highlights**
- Power from 2.8 to 37 kvar
 - Capacitor rated voltage of 280, 415, 440, 480, 525, 690 or 800 V
 - High level of safety through dry technology and 3-phase internal overpressure disconnector
 - Including compact discharge resistor
 - Long operating life

A **construction diagram** is shown on page 35.

multicond-UHPC power capacitors stand out through their combined safety concept with a self-restoring effect and 3-phase internal overpressure disconnector. In low voltage networks, inadmissibly high voltage peaks of up to 3 times the rated voltage can occur through switching operations. If these loads lead to flashovers in the dielectric, the self-restoring effect is triggered. The capacitor remains fully functional as this happens. The 3-phase internal overpressure disconnector is triggered if the amount of gas released by the many self-restoring procedures causes a spe-

cific internal pressure. The lid of the aluminum casing bends slightly and the fuse disconnects all poles of the capacitor from the network.

Note: Depending on the network voltage and when used in detuned systems, a correspondingly higher capacitor rated voltage must be selected. Beyond this, we recommend using power capacitors of the multicond-premium series in networks with increased harmonic load.

Capacitor rated voltage: **280 V – 3-phase**

FREQUENCY	POWER ON NETWORK VOLTAGE											CURRENT ON MAX. VOLTAGE	RATED CAPACITANCE	CONSTRUCTION TYPE	TYPE	Item no.							
	220 V	230 V	280V	–	–	–	–	–	–	–	–						Hz	kvar	kvar	kvar	–	–	–
50	4.6	5.0	7.4	–	–	–	–	–	–	–	–	15.3	3 x 100.1	2 1	premium UHPC-7.4-280-3P basic UHPC-7.4-280-3P	10279 10284							
60	5.5	6.0	8.9	–	–	–	–	–	–	–	18.4												
50	6.9	7.5	11.1	–	–	–	–	–	–	–	22.9	3 x 150.2	3 2	premium UHPC-11.1-280-3P basic UHPC-11.1-280-3P	10281 10285								
60	8.2	9.0	13.3	–	–	–	–	–	–	–	27.5												
50	9.1	10.0	14.8	–	–	–	–	–	–	–	30.5	3 x 200.3	3 3	premium UHPC-14.8-280-3P basic UHPC-14.8-280-3P	10280 10286								
60	11.0	12.0	17.8	–	–	–	–	–	–	–	36.6												

Capacitor rated voltage: **415 V – 3-phase**

FREQUENCY	POWER ON NETWORK VOLTAGE											CURRENT ON MAX. VOLTAGE	RATED CAPACITANCE	CONSTRUCTION TYPE	TYPE	Item no.									
	220 V	230 V	280V	380V	400V	415V	–	–	–	–	–						Hz	kvar	kvar	kvar	kvar	kvar	kvar	–	–
50	14,1	15,4	22,8	41,9	46,4	50,0	–	–	–	–	–	65.6	3 x 308.0	5	UHPC-50.0-415-3P	23497									
60	16,9	18,4	27,3	50,3	55,7	60,0	–	–	–	–	–	78.7													

Capacitor rated voltage: **440 V – 3-phase**

FREQUENCY	POWER ON NETWORK VOLTAGE											CURRENT ON MAX. VOLTAGE	RATED CAPACITANCE	CONSTRUCTION TYPE	TYPE	Item no.									
	220 V	230 V	280V	380V	400V	415V	440V	–	–	–	–						Hz	kvar	kvar	kvar	kvar	kvar	kvar	–	–
50	0.7	0.8	1.1	2.1	2.3	2.5	2.8	–	–	–	–	4.4	3 x 15.4	4	UHPC-2.8-440-3P replaced by UHPC-4.0-525-3P	– 10516									
60	0.8	0.9	1.4	2.5	2.8	3.0	3.4	–	–	–	–	5.3													
50	1.4	1.5	2.3	4.2	4.6	5.0	5.6	–	–	–	–	8.8	3 x 30.8	4	UHPC-5.6-440-3P replaced by UHPC-8.0-525-3P	– 10517									
60	1.7	1.8	2.7	5.0	5.6	6.0	6.7	–	–	–	–	10.6													
50	2.5	2.7	4.0	7.5	8.3	8.9	10.0	–	–	–	–	13.1	3 x 54.8	1 1	premium UHPC-10.0-440-3P light UHPC-10.0-440-3P	10506 21768									
60	3.0	3.3	4.9	8.9	9.9	10.7	12.0	–	–	–	–	15.7													
50	2.8	3.1	4.5	8.4	9.3	10.0	11.2	–	–	–	–	14.7	3 x 61.4	1 1 1	premium UHPC-11.2-440-3P basic UHPC-11.2-440-3P light UHPC-11.2-440-3P	10312 10318 21776									
60	3.4	3.7	5.4	10.0	11.1	2.0	13.4	–	–	–	–	17.6													

Table continued on next page.

Measurements table on page 35

multicond

Capacitor rated voltage: **440 V – 3-phase**

FREQUENCY	POWER ON NETWORK VOLTAGE											CURRENT ON MAX. VOLTAGE	RATED CAPACITANCE	CONSTRUCTION TYPE	TYPE	Item no.
	220 V	230 V	280 V	380 V	400 V	415 V	440 V	-	-	-	-					
Hz	kvar	kvar	kvar	kvar	kvar	kvar	kvar	-	-	-	-	A	µF			
50	3.0	3.3	4.9	9.0	10.0	10.8	12.1	-	-	-	-	15.9	3 x 66.3	1	premium UHPC-12.1-440-3P	10313
60	3.6	4.0	5.9	10.8	12.0	12.9	14.5	-	-	-	-	19.1		1	basic UHPC-12.1-440-3P	10319
								-	-	-	-			1	light UHPC-12.1-440-3P	21769
50	3.5	3.9	5.7	10.5	11.7	12.5	14.1	-	-	-	-	18.5	3 x 77.3	1	premium UHPC-14.1-440-3P	10314
60	4.2	4.6	6.9	12.6	14.0	15.1	16.9	-	-	-	-	22.2		1	basic UHPC-14.1-440-3P	10320
								-	-	-	-			1	light UHPC-14.1-440-3P	21777
50	3.8	4.1	6.1	11.3	12.5	13.4	15.1	-	-	-	-	19.8	3 x 82.8	1	premium UHPC-15.1-440-3P	10315
60	4.5	5.0	7.3	13.5	15.0	16.1	18.1	-	-	-	-	23.8		1	basic UHPC-15.1-440-3P	10321
								-	-	-	-			1	light UHPC-15.1-440-3P	21778
50	4.3	4.7	6.9	12.8	14.1	15.2	17.1	-	-	-	-	22.4	3 x 93.7	2	premium UHPC-17.1-440-3P	10295
60	5.1	5.6	8.3	15.3	17.0	18.3	20.5	-	-	-	-	26.9		1	basic UHPC-17.1-440-3P	10323
								-	-	-	-			1	light UHPC-17.1-440-3P	21779
50	4.5	5.0	7.4	13.6	15.0	16.2	18.2	-	-	-	-	23.9	3 x 99.7	2	premium UHPC-18.2-440-3P	10296
60	5.5	6.0	8.8	16.3	18.0	19.4	21.8	-	-	-	-	28.7		1	basic UHPC-18.2-440-3P	10324
								-	-	-	-			1	light UHPC-18.2-440-3P	21770
50	5.0	5.5	8.1	14.9	16.5	17.8	20.0	-	-	-	-	26.2	3 x 109.6	2	premium UHPC-20.0-440-3P	10297
60	6.0	6.6	9.7	17.9	19.8	21.3	4.0	-	-	-	-	31.4		2	basic UHPC-20.0-440-3P	10325
								-	-	-	-			1	light UHPC-20.0-440-3P	21412
50	5.3	5.7	8.5	15.7	17.4	19.0	21.0	-	-	-	-	27.6	3 x 115.1	2	premium UHPC-21.0-440-3P	21422
60	6.3	6.9	10.2	18.9	20.8	22.0	25.2	-	-	-	-	33.1		2	basic UHPC-21.0-440-3P	10327
								-	-	-	-			1	light UHPC-21.0-440-3P	21413
50	5.3	5.8	8.6	15.8	17.5	18.9	21.2	-	-	-	-	27.8	3 x 116.2	2	premium UHPC-21.2-440-3P	10298
60	6.4	7.0	10.3	19.0	21.0	22.6	25.4	-	-	-	-	33.4		2	basic UHPC-21.2-440-3P	10328
								-	-	-	-			1	light UHPC-21.2-440-3P	21780
50	5.6	6.1	9.1	16.8	18.6	20.0	22.5	-	-	-	-	29.5	3 x 123.3	2	premium UHPC-22.5-440-3P	22975
60	6.7	7.4	10.9	20.1	22.3	24.0	27.0	-	-	-	-	35.4				
50	6.0	6.6	9.8	18.0	20.0	21.5	24.2	-	-	-	-	31.8	3 x 132.6	2	premium UHPC-24.2-440-3P	10299
60	7.3	7.9	11.8	21.7	24.0	25.8	29.0	-	-	-	-	38.2		2	basic UHPC-24.2-440-3P	10331
								-	-	-	-			2	light UHPC-24.2-440-3P	21772
50	6.2	6.8	10.1	18.6	20.7	22.2	25.0	-	-	-	-	32.8	3x 137.0	2	light UHPC-25.0-440-3P	21781
60	7.5	8.2	12.1	22.4	24.8	26.7	30.0	-	-	-	-	39.4				
50	6.8	7.4	11.0	20.3	22.5	24.2	27.2	-	-	-	-	35.7	3 x 149.1	3	premium UHPC-27.2-440-3P	10308
60	8.2	8.9	13.2	24.3	27.0	29.0	32.6	-	-	-	-	42.8		2	basic UHPC-27.2-440-3P	10334
								-	-	-	-			2	light UHPC-27.2-440-3P	21782
50	7.0	7.7	11.4	21.0	23.2	25.0	28.1	-	-	-	-	36.9	3 x 154.0	3	premium UHPC-28.1-440-3P	10300
60	8.4	9.2	13.7	25.2	27.9	30.0	33.7	-	-	-	-	44.3		2	basic UHPC-28.1-440-3P	10335
								-	-	-	-			2	light UHPC-28.1-440-3P	21783
50	7.6	8.3	12.3	22.6	25.0	27.0	30.3	-	-	-	-	39.8	3 x 166.1	3	premium UHPC-30.3-440-3P	10303
60	9.1	9.9	14.7	27.1	30.1	32.4	36.4	-	-	-	-	47.8		2	basic UHPC-30.3-440-3P	10336
								-	-	-	-			2	light UHPC-30.3-440-3P	21773
50	7.8	8.5	12.6	23.3	25.8	27.8	32.2	-	-	-	-	40.9	3x 171.0	2	light UHPC-31.2-440-3P	21784
60	9.4	10.2	15.2	27.9	30.9	33.3	37.4	-	-	-	-	49.1				
50	9.1	9.9	14.7	27.1	30.0	32.3	36.3	-	-	-	-	47.6	3 x 198.9	3	premium UHPC-36.3-440-3P	10305
60	10.9	11.9	17.6	32.5	36.0	38.7	43.6	-	-	-	-	57.1		3	basic UHPC-36.3-440-3P	10337
								-	-	-	-			3	light UHPC-36.3-440-3P	21774
50	10.0	10.9	16.2	29.8	33.1	35.6	40.0	-	-	-	-	52.5	3x 219.2	3	light UHPC-40.0-440-3P	21785
60	12.0	13.1	19.4	35.8	39.7	42.7	48.0	-	-	-	-	63.0				

Up to a power of 30.3 kvar, 440V capacitors are also available in single-phase version. Other capacitor powers on request.

Version: January 2022. Subject to change.

Capacitor rated voltage: **480 V – 3-phase**

FREQUENCY	POWER ON NETWORK VOLTAGE											CURRENT ON MAX. VOLTAGE	RATED CAPACITANCE	CONSTRUCTION TYPE	TYPE	Item no.
	220 V	230 V	280 V	380 V	400 V	415 V	440 V	480 V	–	–	–					
Hz	kvar	kvar	kvar	kvar	kvar	kvar	kvar	kvar	–	–	–	A	µF			
50	2.3	2.5	3.7	6.8	7.5	8.1	9.1	10.8	–	–	–	13.0	3 x 49.7	1	premium UHPC-10.8-480-3P	10377
60	2.7	3.0	4.4	8.1	9.0	9.7	10.9	13.0	–	–	–	15.6		1	basic UHPC-10.8-480-3P	10386
									–	–	–			1	light UHPC-10.8-480-3P	21786
50	2.5	2.7	4.0	7.5	8.3	8.9	10.0	11.9	–	–	–	14.3	3 x 54.8	1	premium UHPC-11.9-480-3P	10378
60	3.0	3.3	4.9	8.9	9.9	10.7	12.0	14.3	–	–	–	17.2		1	basic UHPC-11.9-480-3P	10387
									–	–	–			1	light UHPC-11.9-480-3P	21787
50	2.6	2.9	4.3	7.8	8.7	9.3	10.5	12.5	–	–	–	15.0	3 x 57.6	1	premium UHPC-12.5-480-3P	10379
60	3.2	3.4	5.1	9.4	10.4	11.2	12.6	15.0	–	–	–	18.0		1	basic UHPC-12.5-480-3P	10388
									–	–	–			1	light UHPC-12.5-480-3P	21788
50	3.0	3.3	4.9	9.0	9.9	10.7	12.0	14.3	–	–	–	17.2	3 x 65.9	1	premium UHPC-14.3-480-3P	10380
60	3.6	3.9	5.8	10.8	11.9	12.8	14.4	17.2	–	–	–	20.6		1	basic UHPC-14.3-480-3P	10389
									–	–	–			1	light UHPC-14.3-480-3P	21789
50	3.5	3.8	5.7	10.5	11.6	12.5	14.0	16.7	–	–	–	20.1	3 x 76.9	2	premium UHPC-16.7-480-3P	10365
60	4.2	4.6	6.8	12.6	13.9	15.0	16.8	20.0	–	–	–	24.1		1	basic UHPC-16.7-480-3P	10390
									–	–	–			1	light UHPC-16.7-480-3P	21790
50	3.8	4.1	6.1	11.2	12.4	13.4	15.0	17.9	–	–	–	21.5	3 x 82.4	2	premium UHPC-17.9-480-3P	10366
60	4.5	4.9	7.3	13.5	14.9	16.1	18.0	21.5	–	–	–	25.8		1	basic UHPC-17.9-480-3P	10391
									–	–	–			1	light UHPC-17.9-480-3P	21791
50	4.4	4.8	7.1	13.0	14.4	16.0	17.5	20.8	–	–	–	25.0	3 x 95.8	2	premium UHPC-20.8-480-3P	21425
60	5.2	5.7	8.5	15.6	17.3	19.0	21.0	25.0	–	–	–	30.0		2	basic UHPC-20.8-480-3P	10392
									–	–	–			1	light UHPC-20.8-480-3P	21414
50	5.0	5.5	8.1	14.9	16.5	17.8	20.0	23.8	–	–	–	28.6	3 x 109.6	2	premium UHPC-23.8-480-3P	10367
60	6.0	6.6	9.7	17.9	19.8	21.3	24.0	28.6	–	–	–	34.3		2	basic UHPC-23.8-480-3P	10393
									–	–	–			2	light UHPC-23.8-480-3P	21792
50	5.3	5.7	8.5	15.7	17.4	18.7	21.0	25.0	–	–	–	30.1	3 x 115.1	2	premium UHPC-25.0-480-3P	10368
60	6.3	6.9	10.2	18.8	20.8	22.4	25.2	30.0	–	–	–	36.1		2	basic UHPC-25.0-480-3P	10394
									–	–	–			2	light UHPC-25.0-480-3P	21794
50	5.8	6.4	9.5	17.4	19.3	20.8	23.4	27.8	–	–	–	33.4	3 x 128.0	2	basic UHPC-27.8-480-3P	20358
60	7.0	7.7	11.3	20.9	23.2	24.9	28.0	33.4	–	–	–	40.2			light UHPC-27.8-480-3P	21795
50	6.3	6.8	10.1	18.7	20.7	22.3	25.0	29.8	–	–	–	35.8	3 x 137.2	3	premium UHPC-29.8-480-3P	10369
60	7.5	8.2	12.2	22.4	24.8	26.7	30.0	35.8	–	–	–	43.0		2	basic UHPC-29.8-480-3P	10395
									–	–	–			2	light UHPC-29.8-480-3P	21797
50	7.0	7.7	11.4	20.9	23.2	25.0	28.1	33.4	–	–	–	40.2	3 x 153.8	3	premium UHPC-33.4-480-3P	10371
60	8.4	9.2	13.6	25.1	27.8	30.0	33.7	40.1	–	–	–	48.2		3	basic UHPC-33.4-480-3P	10396
									–	–	–			2	light UHPC-33.4-480-3P	21415
50	7.5	8.2	12.1	22.4	24.8	26.7	30.0	35.7	–	–	–	42.9	3 x 164.4	3	premium UHPC-35.7-480-3P	10374
60	9.0	9.8	14.6	26.8	29.7	32.0	36.0	42.8	–	–	–	51.5		3	basic UHPC-35.7-480-3P	10397
									–	–	–			2	light UHPC-35.7-480-3P	21416

Up to a power of 33.4 kvar, 480V capacitors are also available in single-phase version.

Other capacitor powers on request.

Measurements table on page 35

multicond

Capacitor rated voltage: **525 V – 3-phase**

FREQUENCY	POWER ON NETWORK VOLTAGE											CURRENT ON MAX. VOLTAGE	RATED CAPACITANCE	CONSTRUCTION TYPE	TYPE	Item no.
	220 V	230 V	280 V	380 V	400 V	415 V	440 V	480 V	525 V	–	–					
Hz	kvar	kvar	kvar	kvar	kvar	kvar	kvar	kvar	kvar	–	–					
50	0.7	0.8	1.1	2.1	2.3	2.5	2.8	3.3	4.0	–	–	4.4				
60	0.8	0.9	1.4	2.5	2.8	3.0	3.4	4.0	4.8	–	–	5.3	3 x 15.4	4	UHPC-4.0-525-3P	10516
50	1.4	1.5	2.3	4.2	4.6	5.0	5.6	6.7	8.0	–	–	8.8				
60	1.7	1.8	2.7	5.0	5.6	6.0	6.7	8.0	9.6	–	–	10.6	3 x 30.8	4	UHPC-8.0-525-3P	10517
50	1.6	1.7	2.5	4.6	5.1	5.5	6.2	7.4	8.8	–	–	9.7				
60	1.9	2.0	3.0	5.6	6.2	6.6	7.4	8.9	10.6	–	–	11.7	3 x 34.0	1	premium UHPC-8.8-525-3P	23728
50	1.8	1.9	2.8	5.2	5.8	6.2	7.0	8.4	10.0	–	–	11.0				
60	2.1	2.3	3.4	6.3	7.0	7.5	8.4	10.0	12.8	–	–	13.2	3 x 38.5	1	premium UHPC-10.0-525-3P	10435
														1	basic UHPC-10.0-525-3P	10444
50	2.0	2.1	3.2	5.9	6.5	7.0	7.9	9.4	11.2	–	–	12.3				
60	2.4	2.6	3.8	7.0	7.8	8.4	9.4	11.2	13.4	–	–	14.7	3 x 43.1	1	premium UHPC-11.2-525-3P	23755
50	2.2	2.4	3.6	6.5	7.3	7.8	8.8	10.4	12.5	–	–	13.7				
60	2.6	2.9	4.3	7.9	8.7	9.4	10.5	12.5	15.0	–	–	16.4	3 x 48.1	1	premium UHPC-12.5-525-3P	10436
														1	basic UHPC-12.5-525-3P	10445
														1	light UHPC-12.5-525-3P	21800
50	2.3	2.5	3.7	6.8	7.5	8.1	9.1	10.9	13.0	–	–	14.3				
60	2.7	3.0	4.4	8.2	9.0	9.7	10.9	13.0	15.6	–	–	17.2	3 x 50.0	1	premium UHPC-13.0-525-3P	10437
														1	basic UHPC-13.0-525-3P	10446
														1	light UHPC-13.0-525-3P	21801
50	2.6	2.9	4.3	7.9	8.7	9.4	10.5	12.5	15.0	–	–	16.5				
60	3.2	3.5	5.1	9.4	10.4	11.2	12.6	15.0	18.0	–	–	19.8	3 x 57.7	1	premium UHPC-15.0-525-3P	10438
														1	basic UHPC-15.0-525-3P	10447
														1	light UHPC-15.0-525-3P	21802
50	3.0	3.3	4.8	8.9	9.9	10.6	11.9	14.2	17.0	–	–	18.7				
60	3.6	3.9	5.8	10.7	11.8	12.7	14.3	17.0	20.4	–	–	22.4	3 x 65.4	2	premium UHPC-17.0-525-3P	10418
														1	basic UHPC-17.0-525-3P	10448
														1	light UHPC-17.0-525-3P	21803
50	3.2	3.5	5.1	9.4	10.5	11.2	12.6	15.0	18.0	–	–	19.8				
60	3.8	4.1	6.1	11.3	12.5	13.5	15.0	18.0	21.6	–	–	23.8	3 x 69.3	2	premium UHPC-18.0-525-3P	10430
														1	basic UHPC-18.0-525-3P	10449
														1	light UHPC-18.0-525-3P	21804
50	3.3	3.6	5.4	9.9	11.0	11.9	13.3	15.9	19.0	–	–	20.9				
60	4.0	4.4	6.5	11.9	13.2	14.2	16.0	19.0	22.8	–	–	25.1	3 x 73.1	2	premium UHPC-19.0-525-3P	19867
														1	basic UHPC-19.0-525-3P	10450
														1	light UHPC-19.0-525-3P	21805
50	3.5	3.8	5.7	10.5	11.6	12.5	14.0	16.7	20.0	–	–	22.0				
60	4.2	4.6	6.8	12.6	13.9	15.0	16.9	20.1	24.0	–	–	26.4	3 x 77.0	2	premium UHPC-20.0-525-3P	10431
														2	basic UHPC-20.0-525-3P	10451
														1	light UHPC-20.0-525-3P	21417
50	3.7	4.0	6.0	11.0	12.2	13.1	14.7	17.5	21.0	–	–	23.1				
60	4.4	4.8	7.2	13.2	14.6	15.7	17.7	21.1	25.2	–	–	27.7	3 x 80.8	2	premium UHPC-21.0-525-3P	10419
														2	basic UHPC-21.0-525-3P	10452
														1	light UHPC-21.0-525-3P	21420
50	4.4	4.8	7.1	13.1	14.5	15.6	17.6	20.9	25.0	–	–	27.5				
60	5.3	5.8	8.5	15.7	17.4	18.7	21.1	25.1	30.0	–	–	33.0	3 x 96.2	2	premium UHPC-25.0-525-3P	10420
														2	basic UHPC-25.0-525-3P	10453
														2	light UHPC-25.0-525-3P	21808
50	5.3	5.8	8.5	15.7	17.4	18.7	21.1	25.1	30.0	–	–	33.0				
60	6.3	6.9	10.2	18.9	20.9	22.5	25.3	30.1	36.0	–	–	39.6	3 x 115.5	3	premium UHPC-30.0-525-3P	10421
														2	basic UHPC-30.0-525-3P	10454
														2	light UHPC-30.0-525-3P	21810
50	6.0	6.5	9.7	17.8	19.7	21.2	23.9	28.4	34.0	–	–	37.4				
60	7.2	7.8	11.6	21.4	23.7	25.5	28.7	34.1	40.8	–	–	44.9	3 x 130.9	3	premium UHPC-34.0-525-3P	21874
50	6.5	7.1	10.5	19.4	21.5	23.1	26.0	30.9	37.0	–	–	40.7				
60	7.8	8.5	12.6	23.3	25.8	27.7	31.2	37.1	44.4	–	–	48.8	3 x 142.4	3	premium UHPC-37.0-525-3P	10422
														3	basic UHPC-37.0-525-3P	10455
														2	light UHPC-37.0-525-3P	21421

Up to a power of 34.0 kvar, 525V capacitors are also available in single-phase version. Other capacitor powers on request

Capacitor rated voltage: **690 V – Basic and Premium Y-circuit**

FREQUENCY	POWER ON NETWORK VOLTAGE											CURRENT ON MAX. VOLTAGE	RATED CAPACITANCE	CONSTRUCTION TYPE	TYPE	Item no.							
	220 V	230 V	280 V	380 V	400 V	415 V	440 V	480 V	525 V	600 V	690 V						Hz	kvar	kvar	kvar	kvar	kvar	kvar
50	1.0	1.1	1.6	3.0	3.4	3.6	4.1	4.8	5.8	7.6	10.0	8.4	3 x 22.3	1	premium UHPC-10.0-690-3S	10481							
60	1.2	1.3	2.0	3.6	4.0	4.3	4.9	5.8	7.0	9.1	12.0	10.		1	basic UHPC-10.0-690-3S	10482							
50	1.3	1.4	2.1	3.8	4.2	4.5	5.1	6.1	7.2	9.5	12.5	10.5	3 x 27.9	1	premium UHPC-12.5-690-3S	10475							
60	1.5	1.7	2.5	4.6	5.0	5.4	6.1	7.3	8.7	11.3	15.0	12.6		1	basic UHPC-12.5-690-3S	10483							
50	1.5	1.7	2.5	4.5	5.0	5.4	6.1	7.3	8.7	11.3	15.0	12.6	3 x 33.4	2	premium UHPC-15.0-690-3S	10468							
60	1.8	2.0	3.0	5.5	6.0	6.5	7.3	8.7	10.4	13.6	18.0	15.1		1	basic UHPC-15.0-690-3S	10484							
50	2.0	2.2	3.3	6.1	6.7	7.2	8.1	9.7	11.6	15.1	20.0	16.7	3 x 44.6	2	premium UHPC-20.0-690-3S	10474							
60	2.4	2.7	4.0	7.3	8.1	8.7	9.8	11.6	13.9	18.1	24.0	20.1		2	basic UHPC-20.0-690-3S	10485							
50	2.1	2.3	3.4	6.3	7.0	7.5	8.5	10.1	12.1	15.7	20.8	17.4	3 x 46.4	2	premium UHPC-20.8-690-3S	10469							
60	2.5	2.8	4.1	7.6	8.4	9.0	10.2	12.1	14.5	18.9	25.0	20.9		2	basic UHPC-20.8-690-3S	10486							
50	2.5	2.8	4.1	7.6	8.4	9.0	10.2	12.1	14.5	18.9	25.0	20.9	3 x 55.7	3	premium UHPC-25.0-690-3S	10470							
60	3.0	3.3	4.9	9.1	10.1	10.8	12.2	14.5	17.4	22.7	30.0	25.1		2	basic UHPC-25.0-690-3S	10487							
50	2.7	2.9	4.3	8.0	8.8	9.5	10.7	12.7	15.2	19.9	26.3	22.0	3 x 58.6	3	premium UHPC-26.3-690-3S	10476							
60	3.2	3.5	5.2	9.6	10.6	11.4	12.8	15.3	18.3	23.9	31.6	26.4		3	basic UHPC-26.3-690-3S	10488							
50	2.8	3.1	4.6	8.4	9.3	10.1	11.3	13.5	16.1	21.0	27.8	23.3	3 x 62.0	3	premium UHPC-27.8-690-3S	10478							
60	3.4	3.7	5.5	10.1	11.2	12.1	13.6	16.1	19.3	25.2	33.4	27.9		3	basic UHPC-27.8-690-3S	10489							
50	3.0	3.3	4.9	9.0	10.0	10.7	12.0	14.3	17.1	22.4	29.6	24.8	3 x 66.0	3	premium UHPC-29.6-690-3S	10477							
60	3.6	4.0	5.9	10.8	11.9	12.9	14.4	17.2	20.6	26.9	35.5	29.7		3	basic UHPC-29.6-690-3S	10490							

Measurements table on page 35

Performance data and sizes deviating from the standard are available on request.
Misprints and printing errors as well as technical changes reserved.

Example for order: Power capacitor, 30.3 kvar to 440 V.

The corresponding order detail is as follows: **Type multicond premium UHPC-30.3-440-3P (3-phase version) = item number 10303**

Type multicond basic UHPC-30.3-440-3P (3-phase version) = product number 10336

multicond

Capacitor rated voltage: **800 V – Basic and Premium Y-circuit**

FREQUENCY												CURRENT ON MAX. VOLTAGE	RATED CAPACITANCE	CONSTRUCTION TYPE	TYPE	Item no.
	280 V	380V	400V	415V	440V	480V	525V	600V	660V	690V	800V					
Hz	kvar	kvar	kvar	kvar	kvar	kvar	kvar	kvar	kvar	kvar	kvar	A	µF		multicond...	
50	-	-	3,3	3,6	4,0	4,8	5,7	7,5	9,1	9,9	13,3	9,6	3 x 22.1	1	premium UHPC-13.3-800-3S	21818
60	-	-	4,0	4,3	4,8	5,8	6,9	9,0	10,9	11,9	16,0	11,5		1	basic UHPC-13.3-800-3S	21806
50	-	-	4,2	4,5	5,0	6,0	7,2	9,4	11,3	12,4	16,6	12,0	3 x 27.6	2	premium UHPC-16.6-800-3S	21819
60	-	-	5,0	5,4	6,0	7,2	8,6	11,2	13,6	14,9	20,0	14,4		1	basic UHPC-16.6-800-3S	21807
50	-	-	5,0	5,4	6,1	7,2	8,6	11,3	13,7	14,9	20,1	14,5	3 x 33.3	2	premium UHPC-20.1-800-3S	21820
60	-	-	6,0	6,5	7,3	8,7	10,4	13,5	16,4	17,9	24,1	17,4		2	basic UHPC-20.1-800-3S	21809
50	-	-	5,7	6,2	6,9	8,2	9,8	12,9	15,6	17,0	22,9	16,5	3 x 37.9	2	premium UHPC-22.9-800-3S	21821
60	-	-	6,9	7,4	8,3	9,9	11,8	15,4	18,7	20,4	27,4	19,8		2	basic UHPC-22.9-800-3S	21811
50	-	-	6,7	7,2	8,1	9,6	11,5	15,0	18,1	19,8	26,7	19,3	3 x 44.2	3	premium UHPC-26.7-800-3S	21822
60	-	-	8,0	8,6	9,7	11,5	13,8	18,0	21,8	23,8	32,0	23,1		2	basic UHPC-26.7-800-3S	21812
50	-	-	7,0	7,5	8,4	10,0	12,0	15,7	19,0	20,7	27,9	20,1	3 x 46.2	3	premium UHPC-27.9-800-3S	21823
60	-	-	8,4	9,0	10,1	12,0	14,4	18,8	22,8	24,9	33,4	24,1		2	basic UHPC-27.9-800-S	21813
50	-	-	7,9	8,5	9,6	11,4	13,6	17,8	21,6	23,6	31,7	22,9	3 x 52.5	3	premium UHPC-31.7-800-3S	21997
60	-	-	9,5	10,2	11,5	13,7	16,4	21,4	25,9	28,3	38,0	27,4		3	basic UHPC-31.7-800-3S	21996
50	-	-	8,3	9,0	10,1	12,0	14,4	18,8	22,7	24,8	33,4	24,1	3 x 55.4	3	premium UHPC-33.4-800-3S	21824
60	-	-	10,0	10,8	12,1	14,4	17,3	22,5	27,3	29,8	40,1	28,9		3	basic UHPC-33.4-800-3S	21814
50	-	-	8,8	9,5	10,7	12,7	15,2	19,9	24,1	26,3	35,4	25,5	3 x 58.6	3	premium UHPC-35.4-800-3S	21825
60	-	-	10,6	11,4	12,8	15,3	18,3	23,9	28,9	31,6	42,4	30,6		3	basic UHPC-35.4-800-3S	21815
50	-	-	9,1	9,8	11,0	13,1	15,6	20,4	24,7	27,0	36,3	26,2	3 x 60.2	3	premium UHPC-36.3-800-3S	21826
60	-	-	10,9	11,7	13,2	15,7	18,8	24,5	29,6	32,4	43,6	31,5				
50	-	-	9,3	10,1	11,3	13,4	16,1	21,0	25,4	27,8	37,4	27,0	3 x 61,9	3	basic UHPC-37.4-800-3S	21816
60	-	-	11,2	12,1	13,6	16,1	19,3	25,2	30,5	33,3	44,8	32,3				
50	-	-	9,9	10,7	12,0	14,3	17,1	22,4	27,1	29,6	39,8	28,7	3 x 66,0	3	basic UHPC-39.8-800-3S	21817
60	-	-	11,9	12,8	14,4	17,2	20,6	26,9	32,5	35,5	47,7	34,4				

Measurements table on page 35

Other capacitor powers on request

On request a 4 pole terminal with lead out neutral wire is available.

(suitable for 3 phase controlled pfc units)

Those capacitors can also be used as 3 one phase capacitors in one can.

Only available with diameter of 136mm.

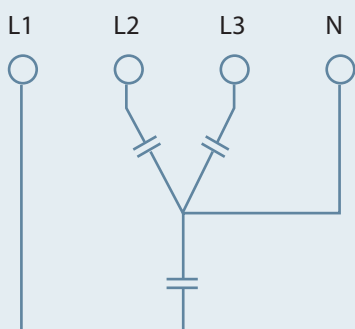

Construction diagram

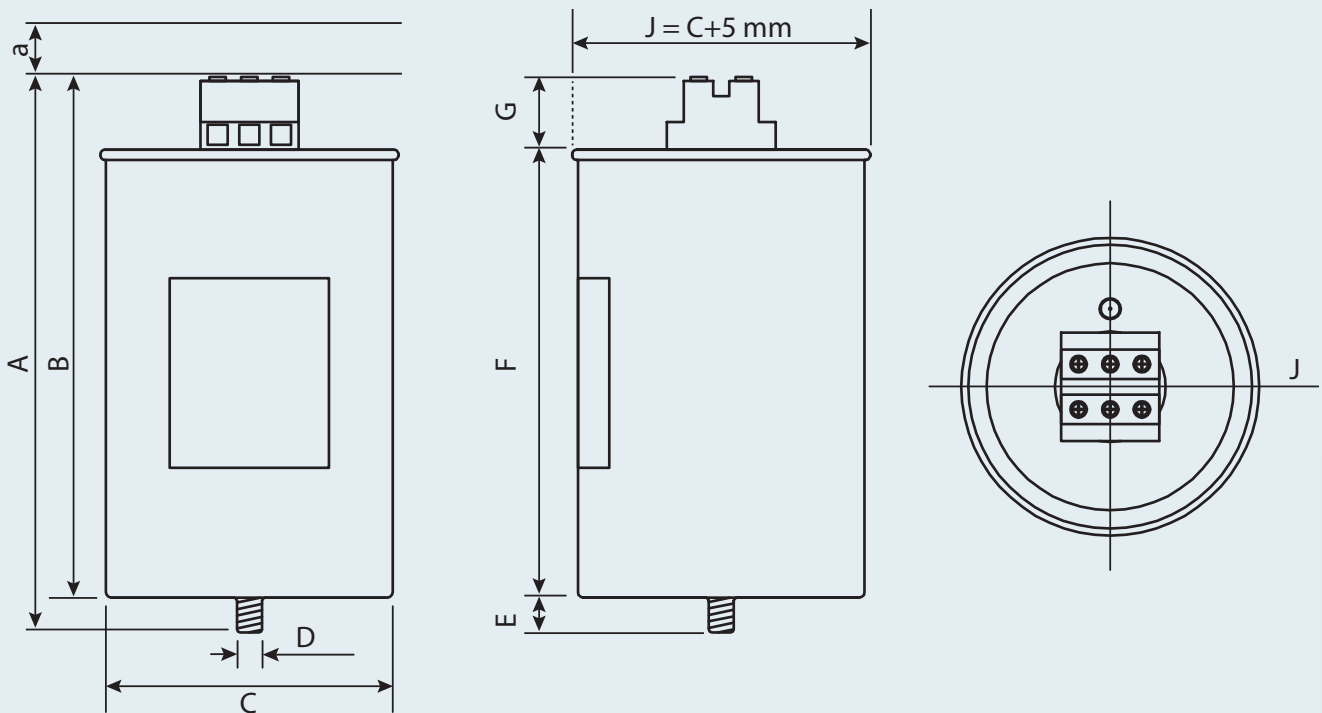

All dimensions are in mm.
Not suitable for measurement purposes.

General:

- Adapter box safe from finger-touch
- Expansion by 12 mm maximum
- Clearance above (a) 13 mm minimum

Installation:

- M12 threaded bolts
- tightening torque $T = 10 \text{ Nm}$
- serrated lock washer J12 DIN 6797
- hexagonal nut BM12 DIN 439

Adapter box:

C 95/116/136 (25 mm²)

- M5 connection screw
- tightening torque $T = 2.5 \text{ Nm}$

C 75 (16 mm²)

- M4 connection screw
- tightening torque $T = 1.3 \text{ Nm}$

Size Chart	A ¹	B ¹	C ¹	D ²	E ¹	F ¹	G ¹	J ^{1,3}	
Construction Type 1	263	246,5	95	11,8 / M12	16,5	212	34,5	100	mm
Construction Type 2	263	246,5	116	11,8 / M12	16,5	212	34,5	121	mm
Construction Type 3	263	246,5	136	11,8 / M12	16,5	212	34,5	141	mm
Construction Type 4	260	243,5	75	11,8 / M12	16,5	212	31,5	79	mm
Construction Type 5	350	334,0	136	11,8 / M12	16,0	290	44,0	141	mm

¹ tolerance +/- 3 mm

² mm / threaded bolts

³J = C + 5 mm

	multicond premium UHPC und multicond UHPC	multicond basic UHPC	multicond light UHPC
Rated voltage	U _n = 280, 415, 440, 480, 525, 690 or 800 V	U _n = 280, 440, 480, 525, 690 or 800 V	U _n = 280, 440, 480, 525 or 690 V
Frequency	50/60 Hz	50/60 Hz	50/60 Hz
Maximum permissible operating voltage	1.0 x U _n continuous 1.1 x U _n 8 hours/day 1.15 x U _n 30 minutes/day 1.2 x U _n 200 x 5 minutes 1.3 x U _n 200 x 1 minute		
Maximum permissible operating current	2.0 x I _n	2.0 x I _n	1.8 x I _n
Maximum inrush current	400 x I _n	400 x I _n	250 x I _n
Capacitance tolerance	+/- 5 %	+/- 5 %	+/- 5 %
Power dissipation	< 0.20 W/kvar, without discharge resistors	< 0.25 W/kvar, without discharge resistors	< 0.25 W/kvar, without discharge resistors
Voltage test (terminal – terminal)	2.15 x U _{rated} (AC), 10 sec	2.15 x U _{rated} (AC), 10 sec	2.15 x U _{rated} (AC), 10 sec
Voltage test (terminal – housing)	≤ 690 V : 3600 V (AC), 2.5 sec > 690 V : 6000 V (AC), 10 sec - acc. to standard		
Cooling	Natural cooling	Natural cooling	Natural cooling
Permissible humidity	95 %	95 %	95 %
Maximum altitude	4000 m above sea level	4000 m above sea level	4000 m above sea level
Installation site, installation position	Indoors, anywhere	Indoors, anywhere	Indoors, anywhere
Attachment	M12 threaded bolts on the ground	M12 threaded bolts on the ground	M12 threaded bolts on the ground
Safety features	→ Dry technology, resin-filled → Self-restoring → Overpressure disconnecter (all-pole) → SF6-free, PCB-free	→ Dry technology, resin-filled → Self-restoring → Overpressure disconnecter (all-pole) → SF6-free, PCB-free	→ Dry technology, resin-filled → Self-restoring → Overpressure disconnecter (all-pole) → SF6-free, PCB-free
Housing	Aluminum		
Protection type	IP 20		
Dielectric	Polypropylene		
Terminal strips	double-sided terminal strip, safe from finger-touch		
Discharge	Discharge resistors on the outside of the strip		
Standards	IEC 60831-1 + 2, EN 60831-1 + 2, VDE 0560-46 + 47		



The discharge of the capacitors takes place via discharge resistors or discharge reactors.

The standard requires a discharge of the capacitor that, as a rule, is realized via discharge resistors.

If faster discharge is necessary, the capacitor can be discharged with a discharge reactor within a very short time.

The capacitor is thus available again for compensation after a short time.

Type	Item no.	Power	Dimensions (H x W x D) in mm	Connection
multidis-EW 120k-3P-5W	17141	5 W	4 x 39 x 30	Terminal lugs
multidis-EW 120k-3P-9W	19410	9 W	4 x 39 x 46	Terminal lugs
multidis-EW 300k-3P	17142	5W	4 x 39 x 30	Terminal lugs
multidis-EW 400k-3P	17143	9W	4 x 39 x 46	Terminal lugs
multidis-ED 100-900V	15464		35 x 60 x 90	cable 600 mm

	multicond premium UHPC und multicond UHPC	multicond basic UHPC	multicond light UHPC
<p>Temperature class D+5:</p> <p>Operating life* > 150,000 h</p> <p>max. ambient temperature: 60 °C max. average over 24 hours: 50 °C max. average over 1 year: 40 °C</p>	<p>Temperature class D+5</p> <p>Life expectancy 150000h</p>		
<p>Temperature class D:</p> <p>Operating life* > 250,000 h</p> <p>max. ambient temperature: 55 °C max. average over 24 hours: 45 °C max. average over 1 year: 35 °C</p>	<p>Temperature class D</p> <p>Life expectancy 250000h</p>	<p>Temperature class D</p> <p>Life expectancy 130000h</p>	<p>Temperature class D</p> <p>Operating Life 100000h</p>
<p>Temperature class C:</p> <p>Operating life* > 150,000 h</p> <p>max. ambient temperature: 50 °C max. average over 24 hours: 40 °C max. average over 1 year: 30 °C</p>	<p>Temperature class C</p> <p>Life expectancy 150000h</p>	<p>Temperature class C</p> <p>Life expectancy 130000h</p>	

***The maximum operating life depends on the type of the application and the temperature class**

Storage conditions for capacitors:

- min. / max. temp.: -40 - + 85 °C
- max. air humidity: <95% without condensation

Do not store in corrosive atmosphere containing aerosols, especially if chloride gas, sulfur compounds, salts (marine air) or similar is present.