



## User manual Technical parameters

**multisio**

**6D6-ESBDS-5DI6RO1DO**



**Your partner for  
network analysis**

© KBR GmbH  
Subject to change

# Table of contents

1	Introduction .....	6
1.1	User manual .....	6
1.2	Intended use .....	6
1.3	Explanation of safety relevant symbols .....	7
1.4	Safety notes .....	7
1.5	Product liability .....	9
1.6	Disposal .....	9
1.7	Serial interface .....	9
1.8	Overvoltage and lightning protection .....	10
1.9	Definition of terms .....	10
2	Installation .....	11
2.1	Device assembly .....	11
2.2	Connection chart .....	12
2.3	Terminal assignment .....	13
2.4	Inserting or replacing backup battery: .....	14
3	Range of functions .....	16
3.1	multisiso 6D6 basic module .....	16
3.2	Expansion modules available .....	17
3.2.1	multisiso 2D2-4DI .....	17
3.2.2	multisiso 2D2-4TI .....	17
3.2.3	multisiso 2D2-4AI .....	17
3.2.4	multisiso 1D2-4CI .....	17
3.2.5	multisiso 2D2-1TI2RO .....	18
3.2.6	multisiso 2D2-4RO .....	18
3.2.7	multisiso 2D2-4DO .....	18
3.2.8	multimes 1D4 energy measuring module .....	19
3.3	Two-tariff counter function (HT / LT) .....	19
3.4	Configurable pulse inputs .....	19
3.5	Configurable pulse output (pulse totalizer) .....	20
3.6	Serial interface for connection to the KBR eBus .....	21
3.7	Extensive memory functions .....	21
3.8	Synchronization .....	22
3.9	Tariff switching .....	22
3.10	Software (required for configuring or reading out memories) .....	22

4	System operation .....	23
4.1	Start-up .....	23
4.1.1	Enabling the scan mode on the device .....	23
4.1.2	LEDs .....	24
4.1.3	Reset .....	24
4.1.5	Basic configuration when delivered .....	25
4.2	Storage .....	25
4.2.1	Device settings .....	25
4.2.2	Long-term memory .....	26
4.2.3	Cycle memory .....	26
4.2.4	Event memory .....	27
4.3	Measuring period synchronization .....	27
4.3.1	Synchronization only by internal clock .....	27
4.3.2	Synchronization by the energy supplier's synchronous pulse .....	28
4.3.3	Synchronization by the KBR eBus .....	28
4.3.4	Synchronization at tariff change .....	29
5	Menu overview .....	30
5.1	Main menus .....	30
5.2	Pulse counter inputs .....	31
5.3	Digital outputs .....	31
5.4	Digital inputs .....	32
5.5	Analog inputs .....	32
5.6	Power measurement inputs .....	32
5.7	Input / output status .....	33
5.8	Error messages .....	33
5.9	Settings .....	33
6	Technical data .....	42
6.1	Technical data multisio 6D6 .....	42
6.1.1	Operating and display elements .....	42
6.1.2	Device memory .....	42
6.1.3	Power supply .....	42
6.1.4	Hardware inputs .....	42
6.1.5	Electrical connection .....	43
6.1.6	Hardware outputs .....	43
6.1.7	Mechanical data .....	44
6.1.8	Dimensioned drawing .....	44
6.1.9	Ambient conditions / electrical safety .....	44

---

6.1.10	Error detection .....	45
6.2	Technical data of display .....	45
6.2.1	Power supply .....	45
6.2.2	Hardware inputs and outputs.....	45
6.2.3	Electrical connection.....	45
6.2.4	Mechanical data.....	45
6.2.5	Ambient conditions / electrical safety.....	46

# 1 Introduction

Thank you for choosing this KBR quality product.

In order to familiarize yourself with the operation and configuration of the device, we recommend that you read this manual thoroughly, so that you are able to make use of the entire range of functions of this high-quality product.

The individual chapters serve to explain the technical details of the device and show how to avoid damage by means of proper installation and commissioning.

## 1.1 User manual

This user manual describes the device version multisio 6D6. This user manual must be accessible for the user at all times (e.g. in the switchgear cabinet). Even when the device is resold to third parties, the manual remains part of the device.

Although we used the utmost care in assembling this user manual, we would like to thank you in advance for notifying us about any errors or ambiguous descriptions you might notice.

## 1.2 Intended use

multisio is a modular system for signal recording and processing. Depending on the input or output type, a wide range of functions can be selected. The device enables you to record the pulses of consumption meters and record them both as a continuous meter count and a standard-compliant load profile.

Alternatively, a digital input can also be used for summarization (switching protocol) or to record the operating hours.

Up to five expansion modules for a wide range of signal forms can be connected to a system center via ready-made RJ45 cables .

### 1.3 Explanation of safety relevant symbols

This user manual contains notes that must be observed for your personal safety and to avoid damage to equipment. These notes are identified by a warning sign or information symbol, depending on the degree of hazard they represent.



#### Warning

"Warning" means that death, major injuries or damage may occur in case the appropriate safety measures are not taken.



#### Caution

"Caution" means that minor injuries or damage may occur in case the appropriate safety measures are not taken.



#### Note

"Note" is an important information on the product, its operation or the respective part of the user manual to which special reference is made.

#### Disclaimer

The content of this user manual has been carefully reviewed in terms of the hardware and software described. Certain deviations, however, cannot be excluded, and the manufacturer is not liable for complete conformity. The specifications made in this user manual are checked on a regular basis, necessary corrections will be included in the next revision.

### 1.4 Safety notes

In order to prevent operating errors, operation of this device is kept as simple as possible. This way, you will be able to quickly start working with the device.

In your own interest, however, you should read the following safety notes carefully.

During assembly, the applicable DIN / VDE regulations must be observed!

Power supply connection, setup and operation of the device must only be performed by qualified personnel. Qualified personnel in accordance with the safety notes in this user manual are persons authorized to set up, ground and mark devices, systems and circuits in accordance with applicable standards and regulations.

To avoid fire and electrical shock, the device must not be exposed to rain or humidity!

Before connecting the device to the power supply, check whether the local power supply conditions comply with the specifications on the nameplate.



### Caution

A faulty connection can lead to the destruction of the device!

When connecting the device, observe the connection chart (see chapter "Connection chart") and make sure that no voltage is applied to the connection lines. Only use proper wiring material and observe the correct polarity when wiring!

In order to ensure proper and safe operation of the product, it must be transported, stored, installed and assembled in accordance with the specifications and operated and maintained carefully.

A visibly damaged device must generally be considered unfit for use and disconnected from the power supply!

Error detection, repair and maintenance work may only be carried out in our facilities or after contacting the service team. Unauthorized opening of the device voids any warranty. Correct operation can no longer be guaranteed!

Opening the device may expose live parts. Capacitors in the device may still be loaded, even if the device has been disconnected from all voltage sources. It is generally not allowed to operate an open device!

In systems subject to hazard of lightning, lightning protection must be provided for all input and output lines!



## 1.5 Product liability

You have acquired a high-quality product. In its production, KBR only uses components of the highest reliability and quality.

Each device is subject to long-term testing before it is delivered.

Regarding product liability, we refer you to our general terms and conditions for electronic equipment, which you can find at [www.kbr.de](http://www.kbr.de)

The warranted characteristics of the device only apply for operation in accordance with its intended use!

## 1.6 Disposal

Defective, outdated or no longer used devices must be properly disposed of.

At your request, we will dispose of the devices for you.

## 1.7 Serial interface

### RS 485 Bus operation

The RS485 interface of the **multisio 6D6** is designed for operation at the KBR eBus. You can operate one or several **multisio 6D6** devices together with the KBR eBus across great distances. Typically, the bus is connected to the computer via the KBR eBus TCP gateway. All bus devices can be configured and displayed with the corresponding KBR® software. We will be glad to provide information on which other devices you can connect to the KBR eBus as well as on the functionality of our software.

Information on the structure and technical parameters of the KBR eBus can be gathered from our installation guide for the KBR eBus. Just send a request for this installation guide.

## 1.8 Overvoltage and lightning protection

It is recommended to install overvoltage protection measures to protect our high-quality devices from damage. We also recommend to protect control voltage inputs and pulse lines, if required.

## 1.9 Definition of terms

Below, you will find brief explanations of the terminology used in this manual.

<b>Firmware:</b>	Operating software implemented in the microcontroller of the <b>multisiso 6D6</b> .
<b>Load profile memory:</b>	Saves the actual values of the measuring periods with timestamp.
<b>Measuring period maximum value:</b>	The measuring period containing the highest (maximum) value that occurred.
<b>Period value:</b>	Cumulated value within a measuring period.
<b>Measuring period:</b>	Refers to the period of time used to form average values. Typical intervals are e.g. 15, 30 or 60 minutes.
<b>DIN rail</b>	Busbar in accordance with DIN EN 50022

## 2 Installation

In this chapter, you will find a description of:

- "Device assembly" on Page 11
- "Connection chart" on Page 12
- "Terminal assignment" on Page 13
- "Inserting or replacing backup battery" on Page 14

### 2.1 Device assembly

The housing of the multisio 6D6 has been designed for wall mounting on a 35 mm DIN rail. The module is assembled to the mounted DIN rail.



#### Caution

The control voltage of the device must be protected by means of a backup fuse.

---

During installation, please also observe our notes on safety measures against overvoltage and lightning in the chapter "Overvoltage and lightning protection" on Page 10.

## 2.2 Connection chart

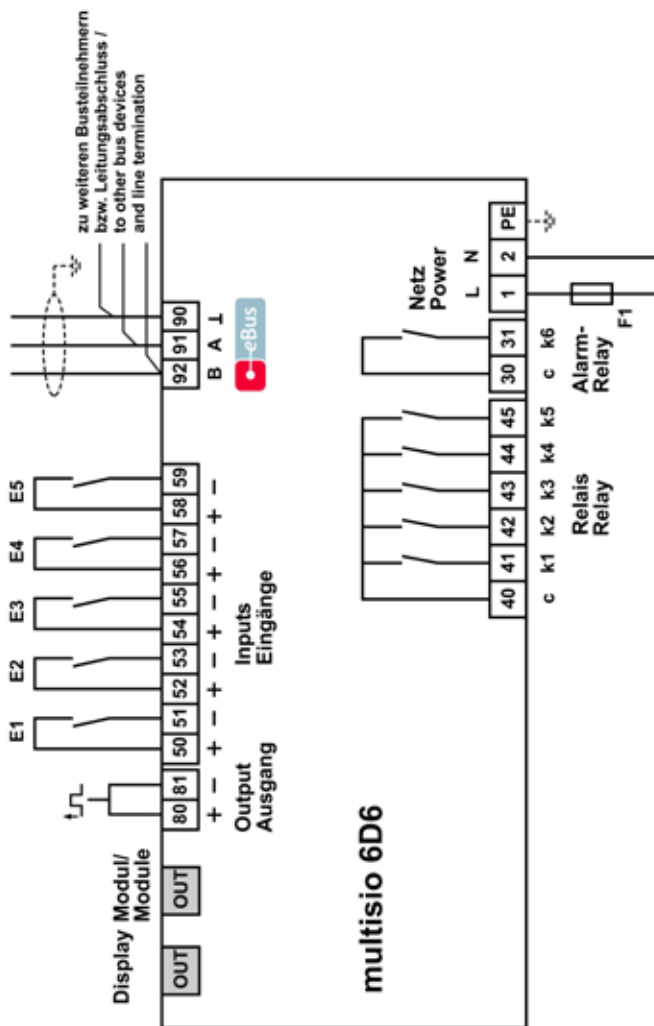

## 2.3 Terminal assignment

Terminals 40 and 41 :	Relay contact, switching capacity 250 V (AC) / 2A
Terminals 40 and 42 :	Relay contact, switching capacity 250 V (AC) / 2A
Terminals 40 and 43 :	Relay contact, switching capacity 250 V (AC) / 2A
Terminals 40 and 44 :	Relay contact, switching capacity 250 V (AC) / 2A
Terminals 40 and 45 :	Relay contact, switching capacity 250 V (AC) / 2A
Terminals 30 and 31:	Floating relay contact, switching capacity 250 V (AC) / 2 A

For error message transmission, e.g. to a master central process control.

Terminal 1 (L) / 2 (N) and PE:	Power supply connection The device can be operated with a voltage from 85 V to 265 V AC/DC 50/60 Hz.
--------------------------------	--

Terminals 80 (+) and 81 (-): Pulse output for pulse totalizer

Terminals 50 (+) and 51 (-): Counter input 1

Terminals 52 (+) and 53 (-): Counter input 2

Terminals 54 (+) and 55 (-): Counter input 3

Terminals 56 (+) and 57 (-): Counter input 4

Terminals 58 (+) and 59 (-): Counter input 5

To these inputs, a pulse generator floating contact can be connected.

Terminal	92 (B)	Bus connection
	91 (A)	For communication on the KBR eBus
	90 (earth):	
Out		Module bus connection For communication with expansion modules
Display		Display connection For communication with the display

## 2.4 Inserting or replacing backup battery:

The device is equipped with an internal data memory, which is battery buffered to preserve long-term data. To prevent it from being discharged, this backup battery (e.g. Varta CR 2032) is not built in when the device is delivered, but included separately in the delivery.



### Caution

Before initial commissioning of the device, please insert the backup battery first (as described in the following), as otherwise all storage data would be lost in case of a power failure.

1. Disconnect the device from the supply voltage.
2. Lift the upper housing cover with a suitable tool (e.g. a small screwdriver).
3. When replacing a battery, remove the empty battery from the clamping bracket with the tool.
4. Push the new battery into the clamping bracket and make sure that it is inserted correctly and has the right polarity.
5. Put the upper housing cover back on and click it into place by pushing.
6. Reconnect the device to the supply voltage.



### Caution

As, when the battery is empty or removed and there is no supply voltage, not only the storage data are lost but the time is not correct anymore either, the time has to be reset in visual energy with the corresponding command!

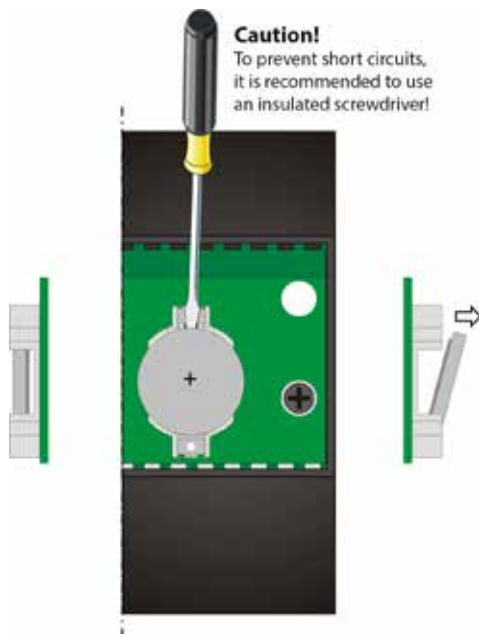

## 3 Range of functions

### 3.1 multisiso 6D6 basic module

**multisiso 6D6** is the central storage module for the multisiso signal recording system. For recording pulses from different pulse generators, the module disposes of five  $S_0$  compatible inputs. The input pulses of each input are added together and divided into measuring periods, given a timestamp and stored in an internal ring buffer. For a measuring period duration of 15 minutes, this results in a recording time of 40 days. A synchronous pulse input can be set up for direct synchronization, and addressed via a floating contact. The floating error message contact of the **multisiso 6D6** can be used to monitor errors and for transmission to a central process control, for example (selectable via a KBR eBus NC or NO contact). The additional five non-floating relay outputs can be assigned to KBR eBus relay groups and used as NC or NO contacts (selectable via KBR eBus).

The **multisiso 6D6** is equipped with a display interface for connection of the multisiso 6F6-DS display via a ready-made RJ12 modular cable. This provides for convenient start-up and configuration of the **multisiso 6D6**. Additionally, momentary values and messages can be displayed.

**The following limits are defined for:**

Energy meter	- Operating hours
Current measurement	- Momentary current - Operating hours
Digital input	- Operating hours
Temperature input	- Momentary temperature - Operating hours
Analog input mA / V	- Momentary value - Operating hours

#### Energy measuring module multimes 1D4:

Parameters:	- Limit 1 momentary power - Limit 2 momentary power - Operating hours counter - Limit Iavg (average current) - Limit Imom (momentary current) - Limit Uph-n (measuring voltage phase-N)
The following can be programmed: limiting values, the address of the message output, as well as values for the limit being exceeded or undercut.	



## 3.2 Expansion modules available

For greater functionality, the device is equipped with a module bus interface for connection of up to five additional modules:

### 3.2.1 multisio 2D2-4DI

The hardware of the **multisio 2D2-4DI** supports four  $S_0$  compatible digital inputs.

With **multisio 2D2 4DI**, you can select between two methods of digital input management. Each input can be configured individually as a pulse counter input or state controlled input.

### 3.2.2 multisio 2D2-4TI

The hardware of the multisio 2D2-4TI supports four PT-1000 temperature inputs.

The module evaluates the measured values of the temperature sensors connected to terminals 70 and 71 etc.

### 3.2.3 multisio 2D2-4AI

The hardware of the multisio 2D2-4AI supports four analog inputs.

With its four analog measuring inputs, current values from 0 to 20 mA and voltage values from 0 to 10 V can be measured. The 4 input LEDs indicate the state of the analog inputs (for operation at the multisio 5D6, the module is always set up for 0-20 mA / 0-10 V, meaning that the LEDs of inputs 1 - 4 are always active).

### 3.2.4 multisio 1D2-4CI

The hardware of the multisio 1D2-4CI supports four analog current measuring inputs and one LED. Currents of up to 6 A can be measured. The device LED displays different device states by flashing or continuous illumination.



#### Caution

The multisio 1D2-4CI may only be operated with series-connected current transformers!

The transformers may not be secondarily grounded. Up to the 690 V network (phase to phase voltage), the connected current transformers have to be designed for a test voltage of at least 2500 VAC for 1 minute.

### 3.2.5 multisio 2D2-1TI2RO

The hardware of the multisio 2D2-1TI2RO supports one PT-1000 temperature input and two floating relay outputs.

The module evaluates the values measured by the temperature sensor connected to terminals 51 and 52 and switches the relays in accordance with the limits transmitted by the master device.

The relay outputs serve for fan control or as an alarm relay.

**Example:**

Operating point fan = 28 °C / hysteresis = 5 °C

Fan relay switches on at 28 °C and off at 23 °C

Operating point alarm = 50 °C / hysteresis = 5 °C

Alarm relay switches on at 50 °C and off at 45 °C

### 3.2.6 multisio 2D2-4RO

The hardware of the multisio 2D2-4RO supports one non-floating control voltage input and four non-floating relay outputs.

Each relay output can be used individually as alarm output, message output for limit violations or digital output.

Optionally, it can be assigned to a KBR eBus relay group.

### 3.2.7 multisio 2D2-4DO

The hardware of the multisio 2D2-4DO supports four digital outputs.

At its outputs, the module provides digital pulses, in accordance with the configuration made by the multisio 6D6 master device via module bus.

For each hardware output, a maximum voltage of 35 V is to be applied to the + input. When in "On" state, the digital output transfers this voltage to the corresponding - terminal. To ensure that the current applied does not exceed 50mA, external wiring is necessary. Fulfilling these parameters, the digital output is S<sub>0</sub> compatible in accordance with DIN 43864.

**Observe correct polarity when connecting.**

### 3.2.8 multimes 1D4 energy measuring module

The hardware of the multimes 1D4 supports four current measuring inputs, four measuring voltage inputs (L1 - L2 - L3 - N) and one status LED. Current measurements are possible up to a maximum of 6 A AC and voltage measurements up to 230 VAC Ph-N. The LED displays different device states by flashing or continuous illumination.

Power supply of the measuring device is provided by the measuring voltage. The operating voltage of the bus interface is supplied via the module bus interface.

#### Limits can be configured for:

- Momentary power limit 1
- Momentary power limit 2
- Operating hours counter
- Average apparent current  $I_m$
- Momentary apparent current  $I$
- Momentary voltage  $U_{ph-n}$

The parameter to be monitored can be selected for each measuring module.

If the set limit is exceeded or undercut, the specified limit relay will issue a message to this effect.

### 3.3 Two-tariff counter function (HT / LT)

Consumption is recorded separately for the different tariff periods. Tariff switching can either be controlled via a digital input, by the KBR eBus (centrally from the multimaster or the computer) or via internal clock.

### 3.4 Configurable pulse inputs

The five configurable pulse inputs, implemented as S0 interfaces, can process pulses from pulse generators up to an input frequency of 16 hertz (minimum pulse length 30 ms, pulse/idle time ratio 1:1). All five pulse inputs can be configured independently. This applies to the configuration of their pulse value (number of pulses per unit) as well as unit (e.g. pulses/kWh). These functions are available via the KBR eBus.

Each pulse is visualized by a flashing LED.

The pulse inputs can optionally be used as:

- Pulse counter
- Heat meter (when using expansion modules with temperature inputs, like the multisio 2D2 4T1 or multisio 2D2 1T12RO)
- Digital input (status display)
- Synchronous pulse input
- Tariff switching input
- Operating hours counter

### 3.5 Configurable pulse output (pulse totalizer)

The configurable pulse output can optionally be used as:

- Alarm output
- Digital output
- Limit message output
- Pulse generator
- Pulse totalizer, with the output, implemented as an S0 interface, able to process pulses up to an output frequency of 16 hertz (minimum pulse length 30 ms, pulse/idle time ratio 1:1).
- Up to 9 pulse inputs can be totaled or subtracted (5 at the basic module + 4 at an expansion module). If the module bus is extended via multisys gateway, even remote counters can be totaled. If only one pulse input is selected as source, this at the same time enables pulse extension via Energy Bus. In this case, observe the following: Input pulses are recorded up to a maximum frequency of 20 Hz. However, output pulses are emitted with a maximum of 16 Hz. Due to the pulse value adaptation, this is however no real limitation in practice.

### 3.6 Serial interface for connection to the KBR eBus

In its default configuration, the **multisio 6D6** has a serial interface (RS485) for operation with the KBR eBus.

Configuration of the unit, as well as reading out the momentary (= instantaneous) or storage data, is possible only via the KBR eBus.

### 3.7 Extensive memory functions

The **multisio 6D6** provides extensive memory functions:

- Cycle memory for recording cumulated input pulses (separately for each input). 5 x 3840 cycle entries, depending on the connected expansion modules up to 25 x 3840 cycle entries.
- Event memory (4096 entries), for logging different actions of the **multisio 6D6** such as power failure, tariff switching actions, delete functions and many more.
- Operation logbook for logging events caused by the device operation (with timestamp).

In detail:

- Each address assignment (date and new address)
- Each parameter change (date and "parameter change")
- Enabling and disabling the project parameter protection (date and "PPP activated" / "PPP deactivated")
- Each supply voltage loss and return (date and event)

User and device specific events (limit violations, switching operations, errors etc.) are not recorded in the operation logbook, but in the event memory.

These memory functions are only available via KBR eBus.

### 3.8 Synchronization

For synchronization of the load profile memory, each digital input can be optionally configured in the **multisio 6D6**. Here, you can for example connect the synchronization signal of the energy supplier. Synchronization can also be controlled centrally via the KBR eBus.

### 3.9 Tariff switching

For tariff switching, each digital input can be optionally configured in the **multisio 6D6**. Here, you can for example connect the tariff switching signal of the energy supplier. Tariff switching can also be controlled centrally via the KBR eBus or via internal clock (refer to chapter "Two-tariff counter function").

### 3.10 Software (required for configuring or reading out memories)

For the convenient configuration and storage of long-term data, make use of the **visual energy** product line.

For questions on this device or on our software products, please do not hesitate to contact us. We will be glad to assist you.

For contact details, please see the cover sheet of this manual.

## 4 System operation

### 4.1 Start-up

#### 4.1.1 Enabling the scan mode on the device

Remove the cover using a suitable screwdriver on the four indentations provided.

Through the opening in the display board, press the button on the upper right of the storage battery for about three seconds.

The LEDs start flashing.

In this phase, an address can be assigned via the KBR eBus computer software. Details of this can be found in the user manual for the corresponding computer software.

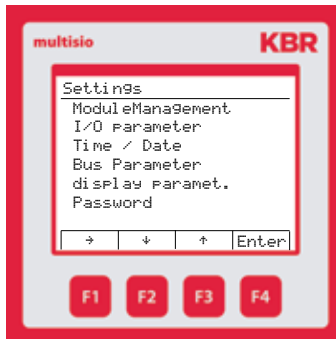

After the address has been assigned successfully, the device enters normal operation. You can also start the scan mode via the display (window: Settings, menu item: Bus parameters):

Bus operation is configured using the Bus parameters item (KBR eBus). Via the KBR energy bus, you can set the bus address here.

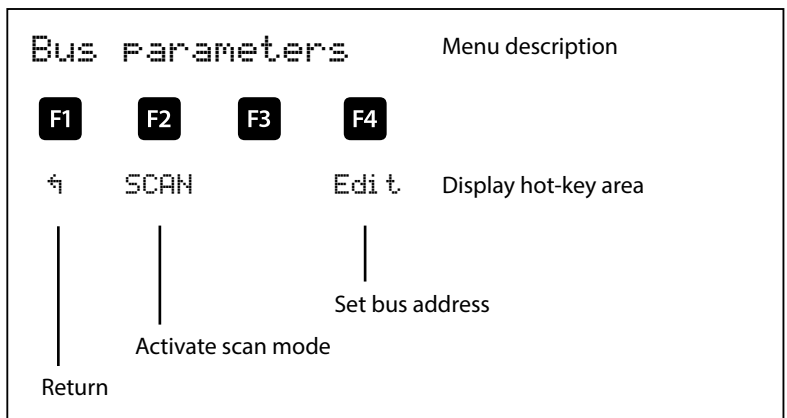

Parameters: Bus address 0 to 9999

### 4.1.2 LEDs

- LED "Power" This LED lights up when the power supply of the device is connected. The device can be operated with a voltage from 85 V to 265 V.
- LED "1 - 5" This LED **flashes** whenever the corresponding **pulse input** is active.

### 4.1.3 Reset



#### Caution

#### Reset procedure:

Disconnect the device from the supply voltage. Remove the cover using a suitable screwdriver on the four indentations provided.

Through the opening in the display board, press the button on the upper right of the storage battery and keep it depressed.

Switch on the supply voltage again.

The LEDs remain lit up.

As soon as you release the button, the device returns to its default state; data and parameter memory are deleted.

You can also perform a reset via the display (window: Settings, menu item: Password).

### 4.1.4 Default settings after reset

Pulse value counter channels 1 to 5	1 pulse / unit
Energy form counter channels 1 to 5	Current
Measuring period duration counter channels 1 to 5	15 min.
Assignment of counter channels 1 to 5	Main module, lines 1 to 5
Synchronization type counter channels 1 to 5	via KBR eBus
Operating hours counter counter channels 1 to 5	No assignment, make contact logic
Inputs channels 1 to 5	No assignment, make contact logic



Relay outputs 1 to 5	Main module, lines 1 to 5, NO contact logic, no relay group assignment
Daylight saving time	from months 03 to 10
Energy form of the ext. synchronous input	Current
Logic of the ext. synchronous input	NO contact logic
Tariff switching	via KBR eBus
Tariff	HT
Default setting for tariff switching triggered by time of internal clock.	Start time: 12:00 AM for LT start End time: 12:00 AM for LT end
All measurements	Restart
Data storage	Deleting all data memories
Measuring period memory	Deleting all entries
Alarm relay	Error message dialog completely set, NC contact logic
Password	Basic setting 9999 device can be accessed

### Unaffected by a RESET:

Bus address and time

#### 4.1.5 Basic configuration when delivered

Bus address	0000
-------------	------

## 4.2 Storage

### 4.2.1 Device settings

All device settings and parameters for the memory function are stored in the device.

## 4.2.2 Long-term memory

With the **multisiso 6D6**, the user can draw upon the long-term memory functionality described in the following section.

## 4.2.3 Cycle memory

The **multisiso 6D6** is equipped with a cycle memory, which can store a maximum of 5 x 3840 entries, depending on the measuring period selected by the user (possible period values are 60 / 30 / 15 / 1 minutes).

This means that a period of 60 minutes results in a maximum storage duration of 160 days.

The measuring period can be configured via the computer, with optionally available software.

When all 5 additional modules are connected, the cycle memory is increased to a total of 25 x 3840.



### Caution

#### Setting the internal clock:

If the device time of the multisiso 6D6 is adjusted by less than the duration of one period, the measurement for the current period is finished and saved at the next synchronization event.

If the time of the multisiso 6D6 is moved back by more than the duration of one period, the load profile memory is deleted and restarted. In both cases, a clock adjustment event is created and saved in the event memory.



### Caution

#### Adjusting the period duration:

If the period duration is adjusted, the load profile memory is deleted and restarted.

An adjustment event (adjustment of the period duration) is created and entered in the event memory.

#### 4.2.4 Event memory

The event memory saves 4096 events with date, time and status in a ring buffer.

**The following events are recorded:**

Event	Acquisition
Tariff switching (via KBR eBus)	Switchover signal => HT with date and time Switchover signal => NT with date and time
Sync input	Missing synchronous pulse with date and time
Mains failures	with date, time and duration of the mains failure
Error	Error type with date and time
Changed settings / deletions	e.g. reset via KBR eBus / set clock / deletions / general parameter changes



#### Caution

The described memories can only be read out or configured via the KBR eBus by means of optionally available software (e.g. visual energy).

### 4.3 Measuring period synchronization

Measuring period synchronization of the multisiso 6D6 can be performed in four different ways. The measuring period synchronization is dependent on the energy form of the sync input on the multisiso 6D6 and on the energy form of the individual inputs. This means that, for example, only inputs with the same energy form as the device's sync input are synchronized.

**The following 4 types of synchronization are possible:**

#### 4.3.1 Synchronization only by internal clock

Synchronization by internal clock is started with the initial reset. From this start time on, the clock synchronizes the measuring period every 15 minutes, depending on the measuring period duration set. Provided the period duration corresponds to the 60 minute schedule, the synchronization time is always 00:00 am (hh:mm).

### 4.3.2 Synchronization by the energy supplier's synchronous pulse

If the synchronous pulse is available as a floating contact from the energy supplier, it may be connected to an input configured as a synchronous pulse input. If the contact closes for at least 250 ms, it is detected as a synchronous pulse, which triggers a restart of the measuring period of the input with the same energy form as the synchronization input.

Under certain operating conditions, the energy supplier may carry out an intermediate synchronization while a measuring period is still running. The **multisiso 6D6** will terminate the running period measurement and save the period value with a timestamp.

#### Example:

Period duration is set to 15 minutes.

I.e. 20 kW input power results in a period value of 20 kW (15 minute period).

If an intermediate synchronization is performed 3 minutes after period start and this 3 minute period is saved, the period value to be recorded is 4 kW.

If no synchronous pulse from the energy supplier is detected, the error message **External synchronous pulse missing** will be displayed and the internal clock will continue the time pattern.

### 4.3.3 Synchronization by the KBR eBus

Synchronization is carried out via a telegram either created by the computer or the MULTIMASTER and sent to the selected recipients via the KBR eBus. This telegram contains the energy form of the input to be synchronized.

Under certain operating conditions, an intermediate synchronization may be carried out while a measuring period is still running.

The **multisiso 6D6** will terminate the running period measurement and save the period value with a timestamp.

#### Example:

Period duration is set to 15 minutes.

I.e. 20 kW input power results in a period value of 20 kW (15 minute period).

If an intermediate synchronization is performed 3 minutes after period start and this 3 minute period is saved, the period value to be recorded is 4 kW.

If no BUS synchronous pulse is detected, the error message **External synchronous pulse missing** will be displayed and the internal clock will continue the time pattern.

#### 4.3.4 Synchronization at tariff change

The internal clock synchronizes the measuring period. Depending on the configuration of the inputs, the measuring period is synchronized in case of a tariff change.

Under certain operating conditions, the synchronization pulse and the internal measuring period synchronization may not be in accordance with the same time pattern. The multisiso 6D6 will terminate the running period measurement and save the period value with a timestamp.

**Example:**

Period duration is set to 15 minutes.

I.e. 20 kW input power results in a period value of 20 kW (15 minute period).

If a synchronization is performed 3 minutes after period start and this 3 minute period is saved, the period value to be recorded is 4 kW.

# 5 Menu overview

## 5.1 Main menus

<p>pulse counter</p> <p>Name Momentary power Cumulative power Tariff Remaining period time continuous energy meter HT continuous energy meter NT</p>	<p>digital output</p> <p>Name Status Output type</p>	<p>digital input</p> <p>Name Status Operating hours Input type</p>	<p>analog input</p> <p>Name Measured value Remaining period time Operating hours Input type</p>
--	--	--	---



Next  
pulse counter



Next  
dig  output



Next  
dig  input



Next  
ana  input

<p>power input</p> <p>Name Momentary power Data point Selectet tariff Remaining period time Continuous meter HT Continuous meter NT Momentary values</p>	<p>I/O status</p> <p>Module number Module type Input status Output status</p>	<p>error messages</p> <p>Current error message Error status Clear error status</p>	<p>settings</p> <p>Module management I/O parameters Time / Date Bus parameters Display parameters Password / Reset to factory settings</p>
--	---	--	--



Next  
power input

Menu  
settings:

<p>Module management</p> <p>Module number Module type Scanmode Firmware version Modulscan bus timeout Flashing Removal</p>	<p>I/O parameters</p> <p>I/O funktions  I/O parameters for: Digital outputs Digital inputs Analog inputs Power measurement</p>	<p>Clock time / Date</p> <p>Time Date Activating daylight saving time Start month End month Device operating time since power failure</p>
<p>Bus parameters</p> <p>Bus type Bus adress Baud rate Scan mode</p>	<p>Display parameters</p> <p>Contrast Brightness Inverted display Display language Dimmer brightness Dimmer delay Display firmware version Display test</p>	<p>Password</p> <p>Enter password Status Delivery reset</p>

Operation of the device is not only possible with the visual energy software, you can also use the multisio 6F6-D5 display for your entries.

The following section provides you with an overview of the display windows and their menu items.

## 5.2 Pulse counter inputs

### Window 1

Counter designation  
 Momentary power  
 Cumulative power  
 Tariff  
 Remaining period time  
 Continuous energy meter:  
 High tariff  
 Continuous energy meter:  
 Low tariff

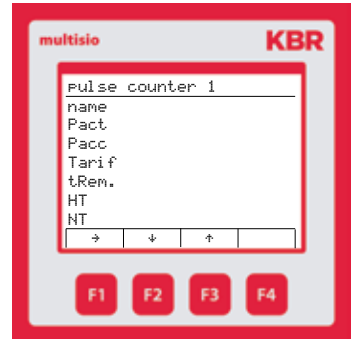

## 5.3 Digital outputs

### Window 2

Counter designation  
 Status  
 Output type

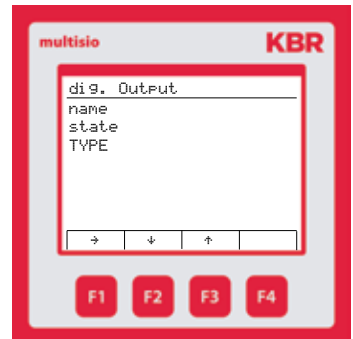

## 5.4 Digital inputs

### Window 3

Input name

Status

Operating hours

Input type

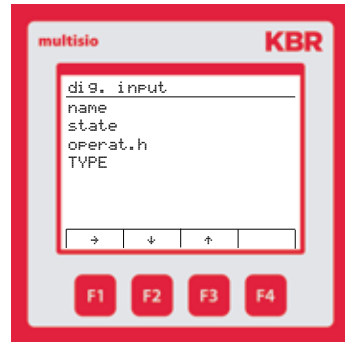

## 5.5 Analog inputs

### Window 4

Input name

Measured value

Remaining period time

Operating hours

Input type

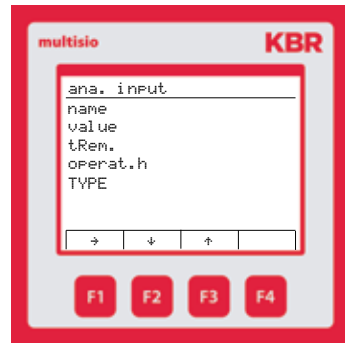

## 5.6 Power measurement inputs

### Window 5

Input name

Momentary power

Data point

Selected tariff

Remaining period time

Continuous meter HT

Continuous meter LT

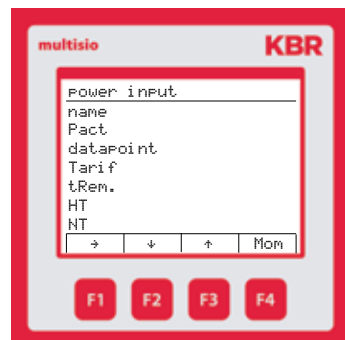



**5.7 Input / output status**

**Window 6**

Module number / type / state

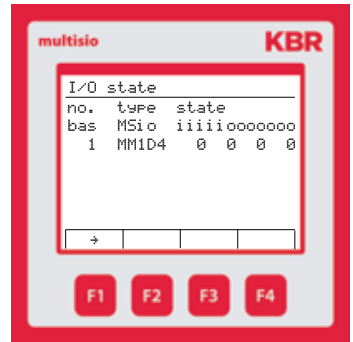

**5.8 Error messages**

**Window 7**

Current error message

Reset error state



**5.9 Settings**

**Window 8**

Sub menus

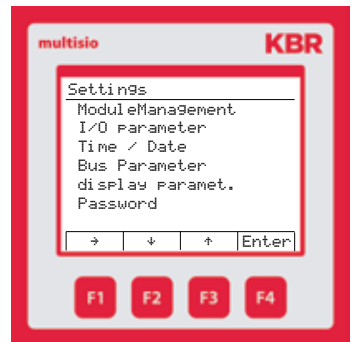

**Status messages (must be acknowledged)**

E01	Mains failure has occurred
E02	A limit has been violated
E03	Counter pulse missing
E04	External synchronous pulse missing
E05	Reset has been performed
E07	Error message

**Active error messages (error state is reset automatically)**

E18	Error module 1 (cannot be reached)
E19	Error module 2 (cannot be reached)
E20	Error module 3 (cannot be reached)
E21	Error module 4 (cannot be reached)
E22	Error module 5 (cannot be reached)

Main menu	Sub menus	Input/ output	Functions	Menu items	Parameter
Settings					
	Module management				
	I/O parameters		Module type		
	Clock time / date		Firmware version		
	Bus parameters		Module bus timeout		
	Display parameters		Flashing		
	Password		Removal		
	I/O parameters				
	Clock time / date	Digital input	Pulse counter		
	Bus parameters			Counter parameters	
	Display parameters				Counter designation
	Password				Inversion
					Pulse value
					Primary transformer voltage
					Secondary transformer voltage
					Primary transformer current
					Secondary transformer current
					t Pmom => 0
					Activate counter failure message

Main menu	Sub menu	Input/output	Functions	Menu items	Parameter
Settings					
	I/O parameters				
	Clock time / date	Digital input	Pulse counter		
	Bus parameters			Cycle memory parameters	
	Display parameters				Tariff switching type
	Password				Start LT time at "internal"
					Stop LT time at "internal"
					Energy type
					period length
					Synchronization type

Main menu	Sub menu	Input/output	Functions	Menu items	Parameters
	I/O parameters				
	Clock time / date	Digital input		Operating hours parameters	
	Bus parameters				Trigger count
	Display parameters				over/below threshold value Pnom
	Password				Threshold value Pnom
					Limit value in hours
					Message output

Main menu	Sub menu	Input/ output	Functions	Menu items	Parameter
	I/O parameters	Digital input			
	Clock time / date		Digital input		
	Bus parameters				Input name
	Display parameters				Activate operating hours counter
	Password				Count for active / passive
					Activate limit message output
					Limit value in hours
					Message output
			Synchronous input		
					Input name
					Inversion
					Energy type
			Tariff switching		
					Input name
					Inversion
					Tariff if activated
					Energy type

Main menu	Sub menu	Input/ output	Functions	Menu items	Parameter
	I/O parameters	Digital input	Heat meter		
	Clock time / date				Input name
	Bus parameters				Inversion
	Display parameters				Pulse value
	Password				Specific heat
					Supply flow temperature input
					Return flow temperature input
					t Pmom => 0
					Activate counter failure message
			Operating hours counter		
					Input name
					Inversion
					Activate limit message output
					Time limit in hours
					Message output
			Cycle memory parameters		
					Tariff switching type
					Start LT time at "internal"
					Stop LT time at "internal"
					Energy type
					Synchronization type
			disabled		

EDEBDA0202-2814-1\_EN

Main menu	Sub menu	Input/output	Functions	Menu items	Parameter
	I/O parameters	Relay output	Alarm relay		
	Clock time / date				Output name
	Bus parameters				Inversion
	Display parameters				active in case of message
	Password	Digital output relay			
					Output name
					Inversion
					Relay group
		Relay output	Limit message output		
					Output name
					Inversion
					ON delay
					OFF delay
		Temperature alarm			
					Output name
					Inversion
					active if value falls below
					Threshold value
					Hysteresis
		disabled			

Main menu	Sub menu	Input/ output	Functions	Menu items	Parameter
	I/O parameters	Digital output	Digital output pulse		
					Output name
					Inversion
					Relay group
			Pulse totalizer		
					Output name
					Pulse length
					Pulse value
					Selection of meter inputs 1 to 9
			Pulse generator		
					Output name
					Pulse length
					Pulse break
					Pulse delay
			disabled		



Main menu	Sub menu	Input / output	Functions	Menu items	Parameter
Settings					
	Clock time / date				Time
	Bus parameters				Date
	Display parameters				Activating daylight saving time
	Password				Start month
					End month
					Device operating time since power failure
	Bus parameters				
	Display parameters				Bus type
	Password				Bus address
					Baud rate
					Scan mode
	Display parameters				
	Password				Contrast
					Brightness
					Inverted display
					Display language
					Dimmer brightness
					Dimmer delay
					Display firmware version
					Display test
	Password				
					Enter password
					Status
					Delivery reset

## 6 Technical data

### 6.1 Technical data multisiso 6D6

#### 6.1.1 Operating and display elements

Operation	Pushbutton for reset and scan mode (accessible after removal of cover)
Control display	6 green LEDs: 5 x input status, 1 x operating status

#### 6.1.2 Device memory

Energy, data and program memory	Pushbutton for reset and scan mode (accessible after removal of cover)
Memory type	Ring buffer
Long-term memory for max. 160 days, min. 64 hours, depending on memory configuration	Load profile memory: Maximum of 5*3840 entries; 60 / 30 / 15 / 1 period duration configurable via operating software!
Event memory	Maximum of 4096 entries for logging tariff switching commands, power failures, error messages etc.
Parameter memory	non volatile
Password memory	4-digit code

#### 6.1.3 Power supply

Power supply	85 to 265V AC/DC; 50/60Hz
Power consumption	15 VA

#### 6.1.4 Hardware inputs

Digital inputs	As pulse counter input 1 to 5	Digital input for floating contact, $S_0$ compatible, pulse duration $\geq 30$ ms
	As status input	Digital input for floating contact, $S_0$ compatible, e.g. for synchronization of the measuring period; pulse duration $\geq 250$ ms

### 6.1.5 Electrical connection

Connection elements		Screw terminals
Max. permissible cross section of the connection lines		2.5 mm <sup>2</sup>
Input Power supply	Fuse protection	F1: Recommended: 1 AT < fuse < 4 AT
KBR eBus connection	Connection material	For proper operation, please only use shielded twisted-pair cables; e.g. I-Y-St-Y 2x2x0.8
Pulse inputs	Connections and cables	ensure proper polarity!
Synchronous input	Connections and cables	ensure proper polarity!
KBR eBus Connection	via RS485	Terminal 90 (L) Terminal 91 (A) Terminal 92 (B)

### 6.1.6 Hardware outputs

Interface	Serial interface	RS 485 for connection to the KBR eBus; a maximum of 32 devices per bus segment, up to 1000 m without bus repeater if placed accordingly, for additional information see installation guide KBR eBus.
	Transmission speed	38400 baud
	Bus protocol	KBR eBus
	KBR eBus Addressing	Can be addressed up to address 9999; via software, scan mode can be activated on the device
Module bus interface	Serial interface	RS 485 (RJ12) for ready-made KBR system cable (6 pole modular cable, unshielded), max. length 30 m when placed accordingly.
Display and configuration interface	Serial interface	RS485 (RJ12)
Relay outputs	Switching stages	5 relays
	Switching capacity	250V (AC) / 2A per relay, potential depending on shared connection
Alarm relay	Switching capacity	250V (AC) / 2A potential-free

EDEBDA0202-2814-1\_EN

### 6.1.7 Mechanical data

Top hat rail device	Housing dimensions	90 x 106 x 61 mm (H x W x D),
	Mounting type	Wall mounting on DIN rail 7.5 mm deep, in accordance with DIN EN 50022
	Weight	approx. 650g

### 6.1.8 Dimensioned drawing

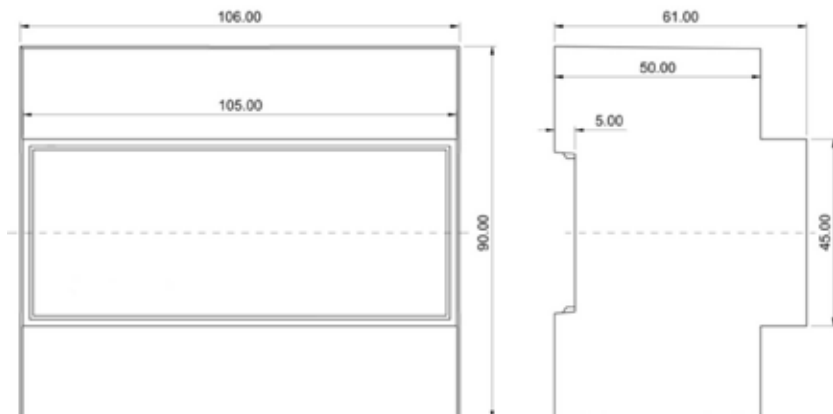

### 6.1.9 Ambient conditions / electrical safety

Ambient conditions	Standards	DIN EN 60721-3-3/A2: 1997-07; 3K5+3Z11; (IEC721-3-3; 3K5+3Z11)
	Operating temperature	-5 °C ... +55 °C
	Humidity	5 % ... 95 %, non-condensing
	Storage temperature	-25 °C ... +70 °C
Electrical safety	Standards and amendments	DIN EN 61010-1: Aug. 2002 (IEC1010-1/A2)
	Protection class	I, in accordance with DIN EN 61010-/ Aug. 2002
	Overvoltage category	CAT III: $U_{PH-PH}$ up to 400V
	Degree of protection	IP20 in accordance with DIN EN 40050 part 9: 1993-05
	Electromagnetic compatibility	DIN EN 61000-6-2: 2000-03; (IEC 61000-6-2) DIN EN 61000-6-3: 2000-03; (IEC 61000-6-3); 2005 - 06

### 6.1.10 Error detection

**No function.**

Check power supply, backup fuse and supply line.

**No display of pulse inputs (LEDs flash)**

Check supply line. Observe correct polarity of inputs.

## 6.2 Technical data of display

### 6.2.1 Power supply

Power supply	ext. 24VDC, 1W, via RJ12 module bus connector
--------------	---

### 6.2.2 Hardware inputs and outputs

Serial interface	Module bus	RS485 via RJ12 interface
	Baud rate	38400

### 6.2.3 Electrical connection

Module bus connection	Connection material	ready-made KBR system cable (6 pole modular cable, unshielded), max. length 30m if placed accordingly
-----------------------	---------------------	---

### 6.2.4 Mechanical data

Flush-mounted device	Housing dimensions	96 x 96 x 46 mm (H x W x D)
	Assembly cut-out	92 x 92 mm
	Degree of protection	Front IP 51
	Weight	approx. 175 g

## 6.2.5 Ambient conditions / electrical safety

Ambient conditions	Standards and amendments	DIN EN 60721-3-3/A2: 1997; 3K5+3Z11; (IEC721-3-3; 3K5+3Z11)
	Operating temperature	-5 °C ... +55 °C
	Humidity	5% ... 95%, non-condensing
	Storage temperature	-25 °C ... +70 °C
Electrical safety	Standards and amendments	DIN EN 61010-1/A2: 1996-05; (IEC1010-1/A2)
	Degree of protection	IP20 in accordance with DIN EN 40050 part 9: 1993-05
	Electromagnetic compatibility	DIN EN 61000-6-3: 2005-06; (IEC 61000-6-3) DIN EN 61000-6-2: 2000-03; (IEC 61000-6-2)



**ERKLÄRUNG DER KONFORMITÄT  
DECLARATION OF CONFORMITY  
DÉCLARATION DE CONFORMITÉ**

**Wir** **KBR GmbH Schwabach**

Wir/Vous (Name des Anbieters / supplier's name / nom du fournisseur)

**Am Kieferschlag 7  
D-91126 Schwabach**

(Anschrift / address / adresse)

**erklären in alleiniger Verantwortung, dass das (die) Produkt(e) /**  
declare under our sole responsibility that the product(s) / Déclarons sous notre seule responsabilité, que le(s) produit(s)

**multisiso 6D6-ESB SDS-5DI6RO1DO**

(Bezeichnung, Typ oder Modell oder Seriennummer / name, type or model or serial number / nom, type ou modèle, N° de lot ou de série)

**mit folgenden Europäischen Richtlinien übereinstimmt (übereinstimmen)**  
is (are) in conformity with the following directives / Répond(s)ert aux directives suivantes

**Niederspannungsrichtlinie Nr.**  
Low Voltage Directive No.  
Directive Basse Tension N°

**EMV-Richtlinie Nr.**  
EMV Directive No.  
EMV Directive N°

**2006/95/EG**  
2006/95/EC  
2006/95/CE

**2004/108/EG**  
2004/108/EC  
2004/108/CE

**Dies wird nachgewiesen durch die Einhaltung folgender Norm(en)**  
This is documented by the accordance with the following standard(s) / Justifié par le respect de la (des) norme(s) suivante(s)

**DIN EN 61010-1:2001;**

**DIN EN 61010-1/BL1:2002**

**DIN EN 61010-1/BL2:2004**

**DIN EN 61000-6-1:2007**

**DIN EN 61000-6-2:2005**

**DIN EN 61000-6-3:2007**

**DIN EN 61000-6-4:2007**

(Titel und/oder Nr. sowie Ausgabedatum der Norm(en)  
Title and/or number and date of issue of the standard(s)  
Titre et/ou numéro et date d'édition de la (des) norme(s)



**Schwabach, 28.03.2012**

(Ort und Datum der Ausstellung  
Place and date of issue  
Lieu et date de l'édition)

Geschäftsführer  
General manager

**KBR GmbH · Am Kieferschlag 7 · D-91126 Schwabach · T +49 (0) 9122 6373-0 · F +49 (0) 9122 6373-83 · E info@kbr.de · www.kbr.de**

EDEBDA0202-2814-1\_EN

## **KBR Kompensationsanlagenbau GmbH**

Am Kiefernschlag 7  
D-91126 Schwabach,  
Germany

Phone +49 9122 6373 -0  
Fax +49 9122 6373 -83  
E-mail [info@kbr.de](mailto:info@kbr.de)

[www.kbr.de](http://www.kbr.de)