



User Manual Technical Parameters



multimes F96 TFT-xxx-5

Table of contents

1	Introduction	6
1.1	User manual	6
1.2	Intended use	6
1.4	Safety notes	9
1.5	Product liability	10
1.6	Disposal	10
2	Range of functions.....	10
2.1	Note for devices with TCP / IP - LAN port	11
3	Device overview	13
3.1	Operating structure.....	13
4	Installation	16
4.1	Device assembly	16
4.1.1	Rotary field.....	17
4.1.2	Asymmetry	17
4.1.3	Current transformer connection.....	18
4.2	Connection diagram	19
4.3	Terminal assignment.....	20
4.4	Buffered long-term memory	21

KBR Kompensationsanlagenbau GmbH does not accept any liability for any loss or damage resulting from printing errors in or changes to this manual.

In addition, **KBR Kompensationsanlagenbau GmbH** does not accept any liability for any loss or damage caused by defective devices or devices manipulated by the user.

Copyright 2021 by **KBR Kompensationsanlagenbau GmbH**
Subject to change.

5	System operation	22
5.1	Control and display panel	22
5.1.1	Description of buttons and displays	23
5.2	Setting range	24
5.3	Basic device configuration	25
5.3.1	Setting the limits	25
6	Menu overview	28
6.1	Main menu Uph-n voltage.....	28
6.2	Main menu Uph-ph voltage.....	28
6.3	Main menu I current.....	29
6.3.1	Submenu Im current average.....	29
6.3.2	Submenu In neutral conductor current.....	29
6.3.3	Submenu Inm average neutral conductor current.....	30
6.4	Main menu S apparent power.....	30
6.4.1	Submenu PQS display of totals for active, reactive and apparent power.....	30
6.5	Main menu P active power:	31
6.5.1	Submenu PQS display of totals for apparent, active and reactive power	31
6.6	Main menu Q reactive power (fundamental).....	31
6.6.1	Submenu PQS display of totals for apparent, active and reactive power	31
6.7	Instantaneous value Cos Phi	32
6.7.1	Submenu power factor	32
6.7.2	Submenu totals of power factors	32
6.8	Main menu F frequency.....	33
6.9	Main menu U_n voltage distortion factor	34
6.9.1	Submenu 3rd harm. U	34
6.11	Main menu W - active and reactive energy / consumption and recovery Menu: W active and reactive energy	36
6.11.1	Submenu W active energy low tariff consumption	36
6.11.2	Submenu W reactive energy high tariff consumption	36
6.11.3	Submenu W reactive energy low tariff consumption	37
6.11.4	Submenu W active energy high tariff recovery.....	37
6.11.5	Submenu W active energy low tariff recovery.....	37
6.11.6	Submenu W reactive energy high tariff recovery.....	38
6.11.8	Submenu W maximum active energy of the period	38
6.12.1	Setting transformer ratio.....	40

6.12.2	Time and bus communication.....	40
6.12.3	Set display and attenuation coefficient	40
6.12.4	Set language and pulse output	41
6.12.5	Configure relay outputs	41
6.12.6	Password and reset.....	41
6.12.7	Zero-point creator.....	42
6.13	Reset to default settings.....	43
7	Technical data in multimess F96 TFT-...-5.....	44
7.1	Measuring and display values	44
7.2	Measurement accuracy class (in accordance with DIN EN 61557-12).....	46
7.5	Power supply	47
7.6	Hardware inputs and outputs.....	48
7.6.1	Hardware inputs	48
7.6.2	Hardware outputs	48
7.7	Electrical connection.....	49
7.8	Mechanical data.....	49
7.9	Standards and miscellaneous.....	50
7.10	Default settings after a reset (delivery state)	51
8	Modbus interface.....	52
8.1	Description Modbus interface for Modbus RTU or ASCII.....	52
8.1.1	Change bus protocol	52
8.2	Ethernet interface for Modbus TCP.....	55
8.2.1	Change bus parameters	55
8.3	Modbus TCP configuration via Ethernet interface (Telnet).....	56
9	Ethernet interface for eBus TCP.....	58
9.1.1	Change bus protocol	58
9.2	KBR eBus TCP configuration using the display	60
9.3	KBR eBus TCP configuration (software configuration).....	61
9.3.1	Assigning an IP Address to a Device of which the Address is Not in the Address Range of the Network.	62
9.3.2	E-port Configuration for eBus TCP	64
10	Data point description for the Modbus protocol	66
10.1	Supported Modbus commands.....	66
10.2	Data formats.....	66

10.3	Interface parameters.....	70
10.4	Optional boards.....	70
10.5	Device settings	71
10.6	Commands	78
10.7	Limit violations.....	80
10.8	Data points	87
10.9	Device information	103

1 Introduction

Thank you for choosing this KBR quality product.

To become familiar with the operation and programming of the device and to use the full range of functions of this high-quality product at all times, you should read this user manual carefully.

The individual chapters explain the technical details of the device and show how damage can be avoided through proper installation and commissioning.

1.1 User manual

This user manual describes the device version multimes F96 TFT-xxx-5. This user manual must be accessible to the user at all times (e.g. in the switchgear cabinet). Even if the device is resold to third parties, the manual remains an inherent part of the device.

Although the utmost care has been taken in writing this user manual, errors may still occur. We would be very grateful if you would notify us of any errors or unclear descriptions you may notice.

1.2 Intended use

This device serves for the monitoring of all important parameters in a three-phase network.

In addition to the Basic version multimes F96-TFT-0-xxx-5, you can choose from additional device versions with extended interface and storage capacity. For a detailed description, see the following section.

Note that the device does not replace close monitoring of the respective parameters by the operator.

**NOTE**

The multimess F96-TFT-xxx-5 is available with different optional boards. Thus, this user manual describes all options possible. To see which device version you have, please refer to the nameplate.

- **Option 0:**
no optional board
- **Option 1:**
optional board with Modbus RS485, 2x relay outputs
- **Option 2:**
not in use
- **Option 3:**
optional board with KBR eBus RS485, Modbus RS485
- **Option 4:**
optional board with Modbus Ethernet, 2x relay outputs
- **Option 5:**
optional board with Profibus DP (unavailable)
- **Option 6:**
optional board with KBR eBus Ethernet, 2x relay outputs
- **Option 7:**
optional board with KBR eBus RS485, Modbus RS485, 2x relay outputs
- **Option 8:**
optional board with KBR eBus RS485, KBR eBus TCP/IP, 2x relay outputs

1.3 Safety keys

This manual contains instructions that you must follow for your personal safety and to avoid material damage. These instructions are identified by a warning sign or information symbol, depending on the degree of hazard they warn about.



DANGEROUS VOLTAGE

"Warning" means that death, major injuries or damage may occur if suitable safety precautions are not taken.



CAUTION

"Caution" means that minor injuries or damage may occur if the appropriate safety precautions are not taken.



NOTE

"Note" is an important piece of information on the product, its operation or the respective part of the user manual to which special reference is being made.

Disclaimer

The contents of these user manual have been carefully reviewed in terms of the hardware and software described. However, deviations cannot be excluded and therefore complete conformity cannot be guaranteed. The specifications made in this user manual are reviewed on a regular basis; any corrections required will be included in the next revision.

1.4 Safety notes

In order to prevent operating errors, device operation is kept as simple as possible. This will enable you to start your device up quickly.

It is in your own interest to read the following safety instructions carefully. The applicable DIN/VDE regulations must be observed during installation!

Power supply connection, setup and operation of the device must be performed by qualified personnel only. Qualified personnel as defined in the safety notes in this user manual are those authorized to set up, ground and mark devices, systems and circuits in accordance with applicable standards and regulations.

To prevent fire and electric shock, do not expose the device to rain or moisture!

Before connecting the device to the power supply, check whether the local power supply conditions comply with the specifications on the device nameplate.



CAUTION

Incorrectly connecting the device can damage it.

For device connection, the data given in the connection diagram must be complied with (see chapter “Connection diagram”) and the connection lines must be voltage-free. When wiring, always ensure that all wiring material used is neither damaged nor defective and that the polarity is correct!

Proper and safe operation of the product requires correct transport, storage, installation and assembly as well as careful operation and maintenance.

If the device has any visible damage it is considered unfit for use and must be disconnected from the mains!

Troubleshooting, repairs and maintenance work may only be carried out at our plant or after contacting our customer service team. If the device is opened without authorization, any warranty or guarantee claim is forfeited. Correct functioning can no longer be guaranteed!

Opening the device may expose live parts. Capacitors in the device may still be charged, even if the device has been disconnected from all power sources. Do not operate open devices under any circumstances!

Systems that are at risk from lightning strikes must feature lightning protection for all input and output lines.

1.5 Product liability

You have purchased a high-quality product. Only top-quality components with exceptional reliability are used.

Each device undergoes a long-term test before delivery.

With regard to product liability, please see our general terms and conditions for electronic devices, which you can read at www.kbr.de.

The warranty on device characteristics only applies if the device is operated in accordance with its intended use!

1.6 Disposal

Please dispose of defective, out-of-date or no longer used devices properly. If required, we will dispose of the device for you.

2 Range of functions

The electronic network measuring devices of the multimes F96 TFT-xxx-5 measure and monitor all important parameters in a three-phase network and are available in different versions. All device versions are equipped with a pulse output.

Aside from the F96 TFT-0-xxx-5 entry level model, the load profile (P+ P- / Q+ Q-) can be saved with all device versions and later read out via KBR eBus. Network voltage can be monitored in accordance with EN 61000-T4-30. In case of a violation, the voltage and current history is saved and can be analyzed on the LCD display. Different optional interfaces and protocols allow various applications.

2.1 Note for devices with TCP / IP - LAN port

This device is also available in a version with a LAN port.

For this version, two options are provided for parameterizing the LAN port:

1. Using the IOT program www.hi-flying.com/download-center-1/applications-1/download-item-iotservice (source of supply).

First the IOT service tool should be installed. After starting the IOT service tool, the connected network is scanned and the reports found are displayed.

2. Using a web browser and the web interface in the LAN port.

The connected device then reports under the factory-set IP address **192.168.0.1**:



HINWEIS

For security reasons, the IP address of the device should be changed immediately to prevent unauthorized access to the device from outside.

In addition, the device should be password-protected (for devices of the multimess series).

The device then reports with the following dialog window, in which the first parameterizations can be made:

Status	
System running status overview	
System State	
Product Name E88	MAC 9896B8A3D42
DHCP Disable	IP 192.168.0.1
Subnet Mask 255.255.255.0	Gateway 0.0.0.0
DNS 0.0.0.0	Firmware Version 3.26
System Time NTP Disabled	Total Running Time 0 Day 3:53
Remaining RAM 27576	Max Block Size 26208
Configuration Protected Disable	
Serial Port State	
Received Bytes 1	Received Frames 1
Sent Bytes 0	Sent Frames 0
Failed Bytes 0	Failed Frames 0
Config 00000,1,2076	
Communication State - 'telnet'	
Received Bytes 0	Received Frames 0
Sent Bytes 0	Sent Frames 0
Failed Bytes 0	Failed Frames 0
Protocol TCP 65535	State Socket Created
Client Ip	

The device then reports with the following dialog window, in which the first parameterizations can be made:

Further settings can then be made on the following pages.

The screenshot displays a configuration interface with the following sections and fields:

- User Name:** admin
- Password:** *****
- Basic Settings:**
 - Host Name:** mmess et. BA1042
 - Network Mode:** Router
- WiFi Settings:** (Empty section)
- WAN Settings:**
 - DHCP:** Off
 - WAN IP:** 192.168.0.1
 - Subnet Mask:** 255.255.255.0
 - Gateway:** 0.0.0.0
 - DNS:** 0.0.0.0
- LAN Settings:**
 - LAN IP:** (Empty field, error: "The LAN IP field is required.")
 - Mask:** (Empty field, error: "The Mask field is required.")
 - DHCP Server:** Off
- Telnet Settings:**
 - Enable:** On
 - Telnet Port:** 23
 - Echo:** Off
- Web Settings:**
 - Enable:** On
 - Web Port:** 80
- NTP Settings:**
 - Enable:** Off

The user name (User) and the password for System Settings are factory-set to:

- Username: admin
- Password: admin
- "Flow Control: Half-Duplex" controls the switching of the RS485 module.
- The web port must be set to 8000.
- Gap Time should be set to 10 (ms)
(Waiting time after serial reception until telex is sent over the network).
- Cli Waiting Time should be set to a maximum of 15 (seconds).

3 Device overview

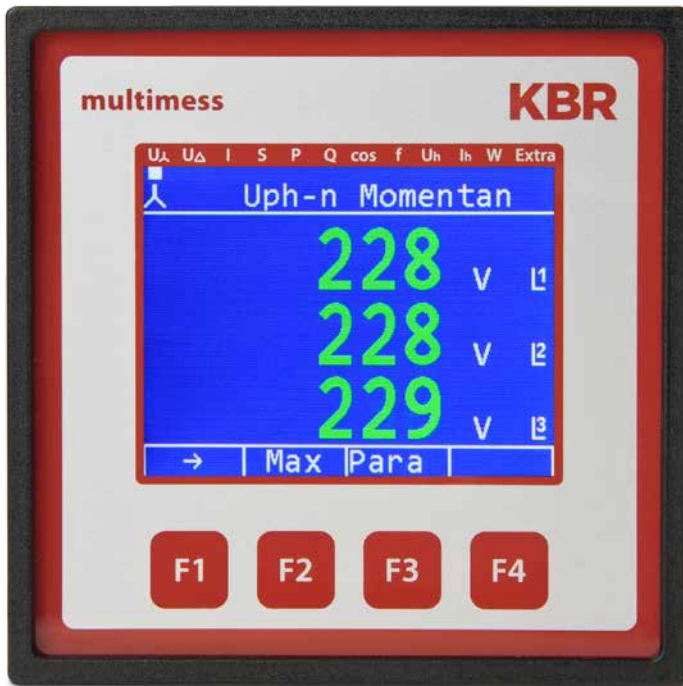

3.1 Operating structure

The following gives you an overview of the entire operating structure at a glance. For a detailed description, please refer to "Menu overview".

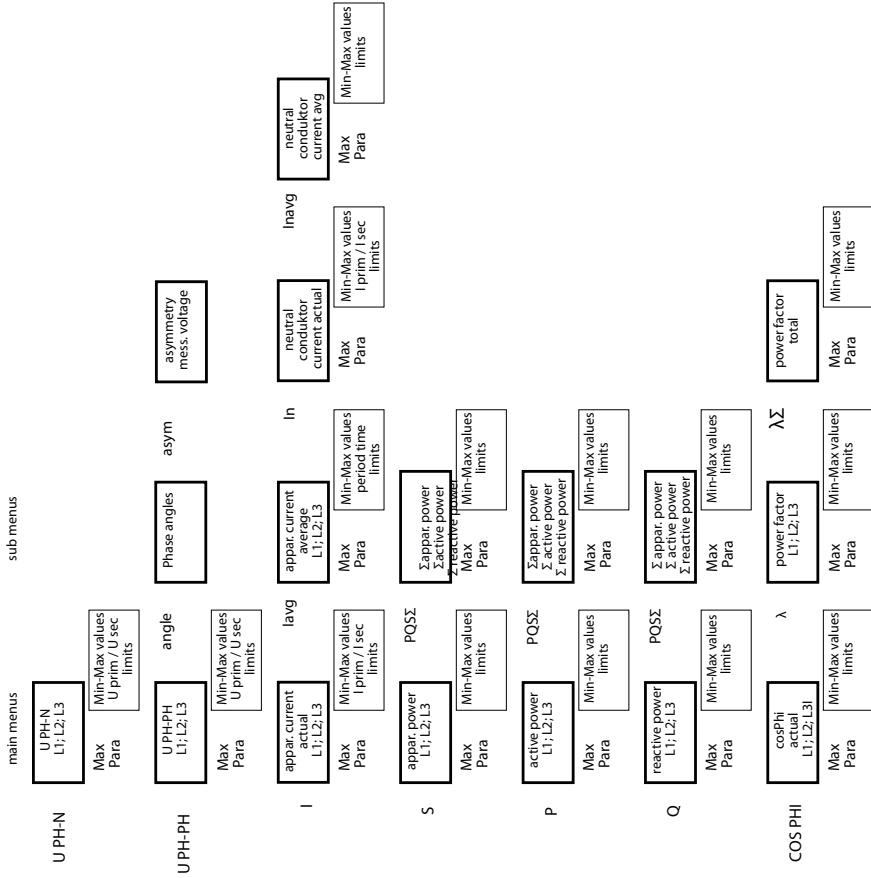

26195_EDEBD A0297-0921-1_EN

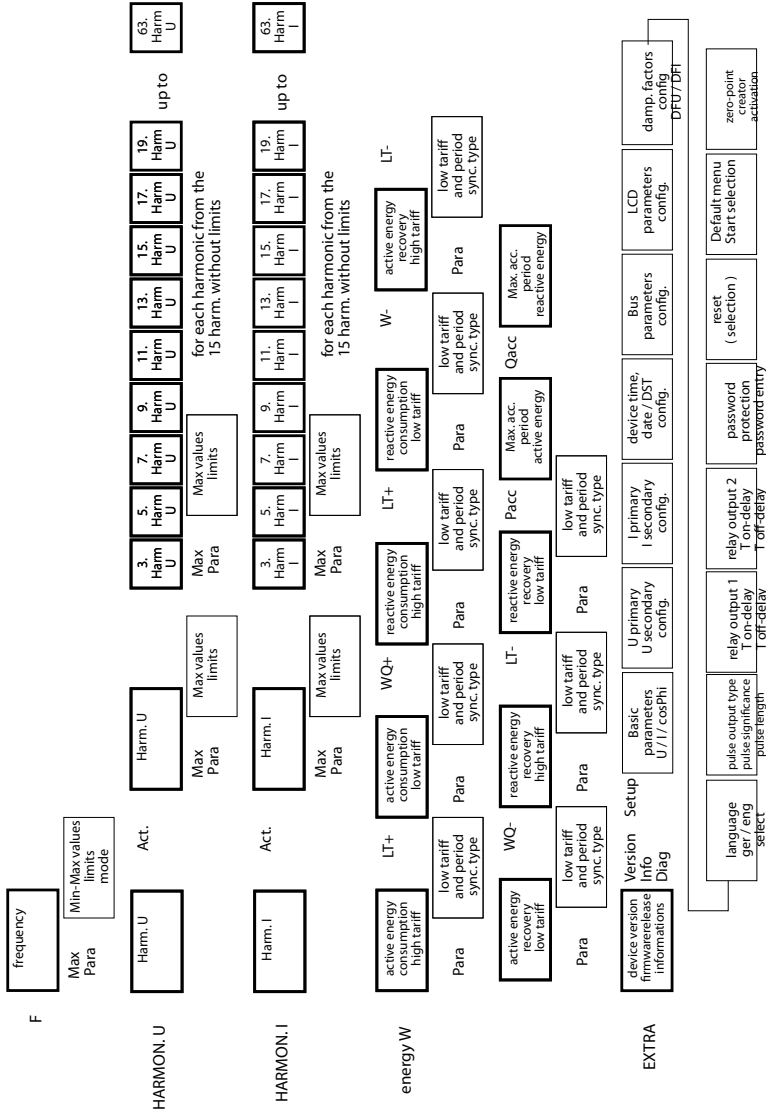

4 Installation

This chapter describes:

- "Device assembly"
- "Connection diagram"
- "Terminal assignment"
- "Buffered long-term memory"

4.1 Device assembly

The applicable VDE regulations must be observed during installation! Before the device is connected to the power supply, check whether the local power supply conditions comply with the specifications on the nameplate. Incorrect connection may result in the destruction of the device. A different mains frequency can also affect the measurement.

The device must be connected in accordance with the connection diagram.

The power supply input of systems that are at risk from lightning strikes must be equipped with suitable lightning protection.



CAUTION

The control voltage as well as the applied measuring voltage of the device must be protected using a back-up fuse. When connecting the current transformer, the energy flow direction and the correct assignment to the voltage path must be observed.

For the wiring of the pulse output, we recommend to exclusively use shielded twisted pair material, to avoid disturbance (e.g. installation line I-Y(ST) Y 2x2x0.8mm, whereas the shielding may only be connected on one side).

During installation, please also observe our safety instructions to protect against over-voltage and lightning in the "Protective measures" chapter of this manual.



NOTE

The following points must be taken into account when connecting the device to the three-phase network you want to be measured:

- Direction of energy flow
- Assignment of measuring voltage input/current transformer input

4.1.1 Rotary field

The device can be operated with a clockwise or anti-clockwise rotary field. When mains to the device is switched on, the multimeter F96 TFT-xxx-5 automatically checks the direction of rotation. Rotary field check:

1. Connect only the measuring voltage to the device (U_{meas} see nameplate).
2. Switch the device on by connecting the power supply cable voltage to the power supply connections (L and N). The device checks the mains direction of rotation immediately after being switched on.
3. The rotary field is displayed in the menu UPH-PH, submenu Angle.
4. For a clockwise rotary field, the display shows L1 0, L2 120 and L3 240 degrees.
5. If you want to change the direction of rotation from clockwise to anti-clockwise, simply swap two terminals, i.e. two phases, then switch the device OFF and ON again. The display now shows the correct voltage and the device starts measuring automatically.
6. Then, check again whether the assignment of voltage path L1 and current path L1, as well as for all other phases, is still correct.

4.1.2 Asymmetry

The rotary field is displayed in the menu $U_{\text{PH-PH}}$, submenu Angle / A_{sym} .

The voltage asymmetry is displayed according to standard EN 6100-4-30:2003.

Shows the asymmetric load of the three phase network.

The display Asymmetry is shown and the value is displayed in %.

4.1.3 Current transformer connection

■ Direction of energy flow

When mounting the transformer, observe the current flow or energy flow direction. If the current transformer is mounted the wrong way, the measured value will be negative. A prerequisite for this is that energy is supplied to the device.

■ Assigning the measuring voltage input/current transformer input

The current transformer on terminal 20/21 (k1/l1) must be installed in the phase in which the measuring voltage for terminal 10 (L1) is measured. The same applies to the other transformer and measuring voltage connections.

You can check the phase sequence as follows using the multimes F96 TFT-xxx-5:

1. Go to the main menu "I".
2. Connect the current transformer to the corresponding wires.
3. If the connection and direction of energy flow are correct, the device will only display positive currents. 4. If the device is connected incorrectly, all currents displayed will be negative. Interchange the connections until the display shows correct values.



CAUTION

Before any interchanging, the current transformers must be shorted out!

4.2 Connection diagram

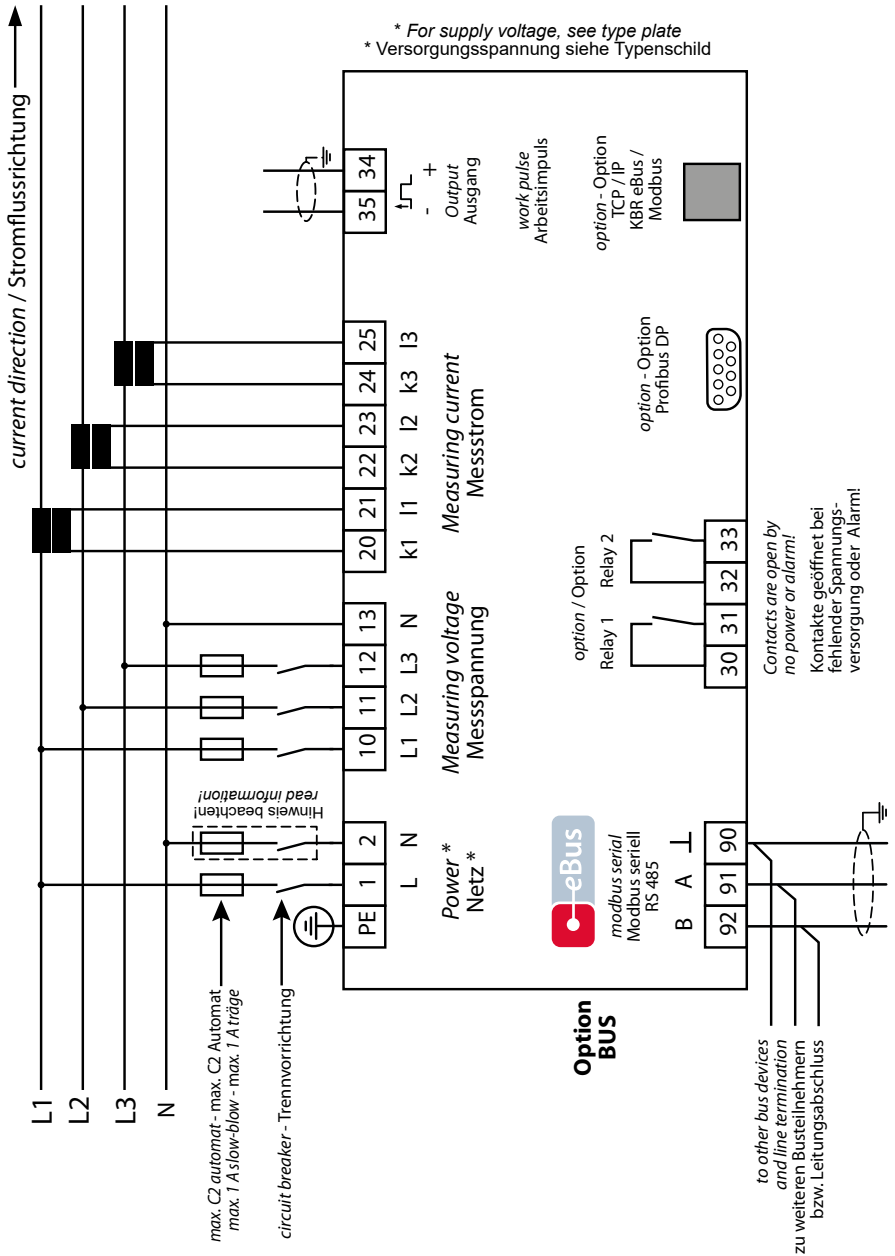

4.3 Terminal assignment

Terminals 1 (L) and 2 (N):	<p>Power supply connection</p> <p>A control voltage is required to supply the device with power. The device has a multi-range power supply unit and can be supplied with different selectable voltages (see nameplate).</p>
Terminal 10 (L1): Terminal 11 (L2): Terminal 12 (L3): Terminal 13 (N):	<p>Voltage measuring input</p> <p>Three-phase voltage measurement in three-wire as well as four-wire rotary current networks. Direct measurement for 3x5...100...120V or 3x20...500...600V AC. The measuring range is configurable. If the measuring range is exceeded, an error message is displayed. For higher voltages, the device needs to be connected via a voltage transformer. For IT networks, a zero-point creator is required.</p>
Terminal 20 (k1) and 21 (l1): Terminal 22 (k2) and 23 (l2) Terminal 24 (k3) and 25 (l3)	<p>Current measurement inputs</p> <p>The measuring inputs for current must be connected via current transformers x/1A AC or x/5A AC.</p> <p>When connecting transformers, pay attention to the direction of energy flow and the correct assignment of measuring voltage inputs to the current transformers.</p>
Terminal 30 and 31:	<p>Floating relay contact relay 1</p> <p>This contact serves as a message or alarm output. During operation, an acoustic or visual message can be activated or a consumer switched off using this relay. The contact is open as long as the device is dead as well as when there is an active message. Maximum switching capacity 2A at 250V AC.</p>
Terminal 32 and 33:	<p>Floating relay contact relay 2</p> <p>Refer to the description of the floating relay contact relay 1</p>

Terminal 34 (+) and 35 (-):	<p>Pulse output</p> <p>Output of energy-proportional pulses via a digital contact (S0 interface in accordance with DIN 43864). Ensure that the output has the right polarity. The output signals can be processed by a maximum demand monitor or a master central process control, for example.</p>
Terminal 90 (ground): Terminal 91 (A): Terminal 92 (B):	<p>Interface connection</p> <p>For communication on the KBR eBus or Modbus</p>

4.4 Buffered long-term memory

The device is equipped with internal data memory (flash). After an uninterrupted charging time (device connected to the supply voltage) of approx. 100 hours, the buffer capacitor will have a sufficient charge to protect the internal clock from failure due to lack of operating voltage for approx. 7 days.



CAUTION

If the buffer capacitor is discharged and it is not connected to a power source, the time settings will be lost and will need to be reset!

5 System operation

In this chapter, you will find instructions on how to operate the multimes F96 TFT-xxx-5 in daily use. Furthermore, it contains references to the complete range of functions.

5.1 Control and display panel

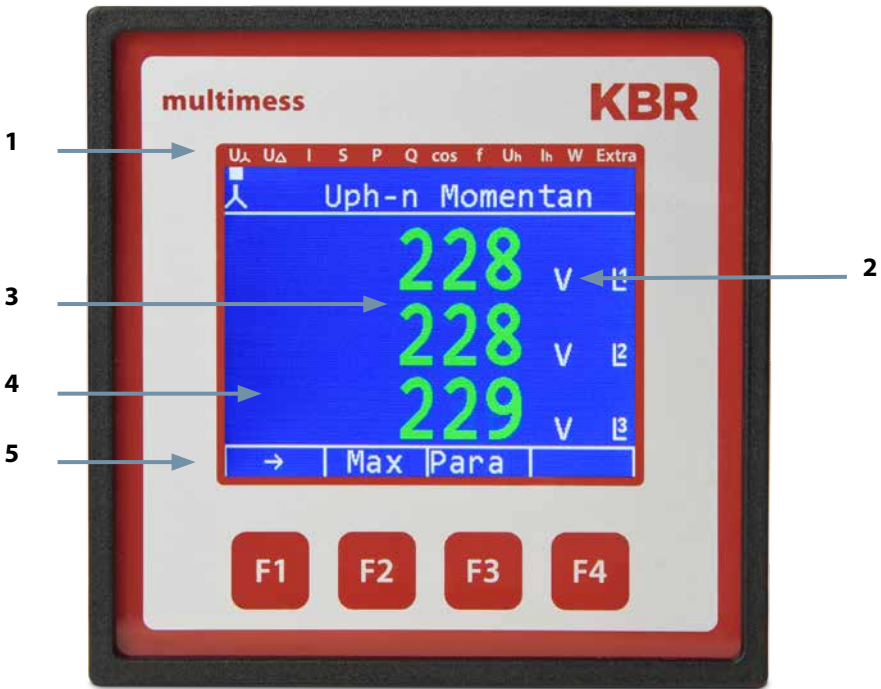

5.1.1 Description of buttons and displays

1 Display navigation panel

The navigation panel shows the main menu selected, considerably simplifying operation of the device. The operator can immediately see what menu he is in.

2 Unit display

The unit display is normally used to show measured values. Each phase has its own display. In some submenus, this display area is used to show additional information to assist operation.

3 Measuring range

These displays are used to represent measured, stored and programmed values. In some submenus, they are also used to simplify configuration with simple text output.

4 Additional information area

Additional information is conveyed with simple and self-explanatory icons. This additional information makes it easier for the operator to interpret the recorded values.

5 Hot key area

The text line corresponds to the button keys lying below it and is used to issue messages and text. The interaction between key and corresponding display ensures user-friendly and self-explanatory operation.

5.2 Setting range

The following setting ranges are available for configuration of the unit:

Measuring voltage, primary	1 V to 9999 kV
Measuring voltage, secondary	100 V to 500 V
Measuring current, primary	1A to 99.99 kA
Measuring current, secondary	1A to 5 A
Limits	depending on the configured transformer values
Current average time	1 to 15 minutes
Limits Cosφ	inductive 0.00 to capacitive 0.00
Frequency correction	Automatic - 50 Hz - 60 Hz
Limits frequency	00.00 Hz to 65 Hz
Limits voltage harmonics	00.0% to 99.9%
Limits current harmonics	0 to 300 A
Attenuation coefficient voltage (display)	0 to 6
Attenuation coefficient current (display)	0 to 6
Working pulse output	Active and reactive energy 0.001 to 9990 pulses per KWH or kvar
Energy pulse duration	30 to 990 milliseconds
Signaling relay ON-delay	0 to 254 seconds
Signaling relay shutdown delay	0 to 254 seconds
Measurement period synchronization	Internal, KBR eBus, for tariff switching
Tariff switching	Internal, KBR eBus

5.3 Basic device configuration

The menu navigation of the multimess F96 TFT-xxx-5 is self-explanatory.

The operator is guided and supported by the device through operating instructions displayed for the respective situation.

As an example of the basic procedure of programming, the functions in the U Phase - N menu will be looked at more closely.

The screenshot shows a menu with a red border. At the top, a navigation bar contains icons for U_A, U_Δ, I, S, P, Q, cos, f, U_h, I_h, W, and Extra. The main display shows 'Uph-n actual' with a 'menu headline' below it. A 'hotkey area' below that contains '→ Max Para' and a note 'after pressing a key see on the right'. Below the hotkey area are four function buttons: F1, F2, F3, and F4.

- F1** Scroll through main menu
- F2** Display and processing of minimum and maximum values
- F3** Entry for configuration => limits and voltage transformer

5.3.1 Setting the limits

After pressing the **F3** (Para) button, the following is displayed in the hot key area:

Menu: U phase - N

The screenshot shows a menu with a red border. At the top, a navigation bar contains icons for U_A, U_Δ, I, S, P, Q, cos, f, U_h, I_h, W, and Extra. The main display shows 'Uph-n Parameter' with a 'menu headline' below it. A 'hotkey area' below that contains '← JHEU Lim1 Lim2' and a note 'after pressing a key see on the right'. Below the hotkey area are four function buttons: F1, F2, F3, and F4.

- F1** Return
- F2** Display and processing for voltage transformer
- F3** Configuration limit 1
- F4** Configuration limit 2

After pressing the **F3** (GW1) button, the following display appears in the hot key area of the display:

Menu: U phase - N

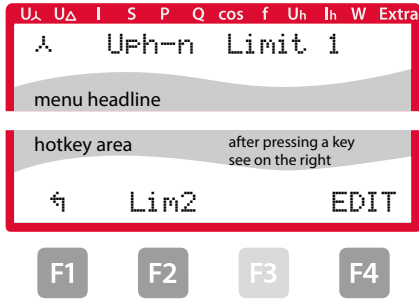

- F1** Return
- F2** Change to processing of limit 2
- F3** Hysteresis for limit 1 or 2
- F4** Configuration limit 1

After pressing the **F4** **↵** button, the following is displayed in the hot key area:

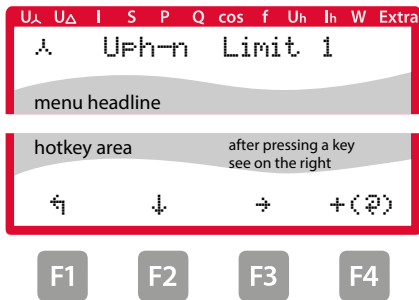

- F1** Return
- F2** Scroll through lines in the value range
- F3** Continue to next digit
- F4** + Value input (Ⓜ function selection)

If the setting was changed, the following display appears after the third line in the hot key area of the display if the **↓** key (scrolling function) is pressed:

Menu: U phase - N

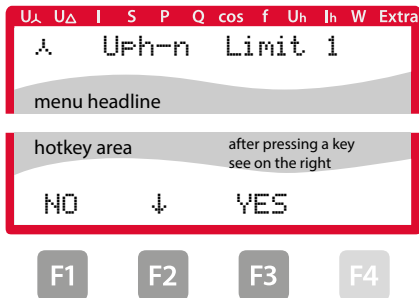

- F1** Leave setting menu without saving
- F2** Scroll through lines in the value range
- F3** Leave settings menu and save

After pressing the **F3** (EDIT) button, the following is displayed in the hot key area:

Menu: U phase - N

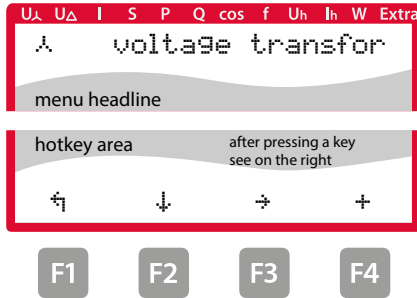

- F1** Return
- F2** Scroll through lines in the value range
- F3** Continue to next digit
- F4** + Value input

If the setting was changed, the following display appears after the third line in the hot key area of the display if the **↓** key (scrolling function) is pressed:

Menu: U phase - N

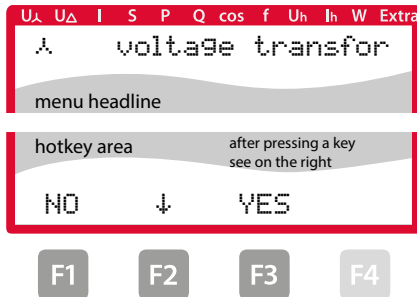

- F1** Leave setting menu without saving
- F2** Scroll through lines in the value range
- F3** Leave settings menu and save

6 Menu overview

In this chapter, you will find a complete overview of all menus and menu items of the multimess.

6.1 Main menu Uph-n voltage

Menu: U phase - N

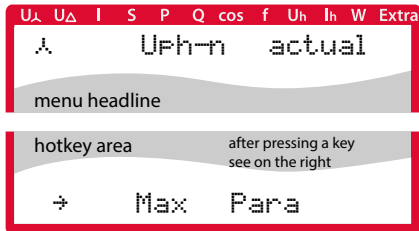

- F1 Scroll through main menu
- F2 Display and processing of minimum and maximum values
- F3 Entry for configuration => limits and voltage transformer

6.2 Main menu Uph-ph voltage

Menu: U phase - phase

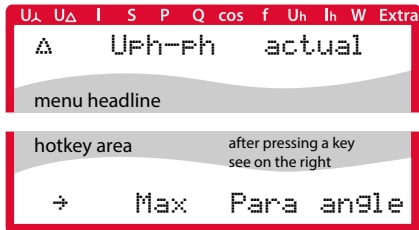

- F1 Scroll through main menu
- F2 Display and processing of minimum and maximum values
- F3 Configuration => limits and voltage transformer
- F4 Display of phase angle and measuring voltage asymmetry

6.3 Main menu I current

Menu: I instantaneous

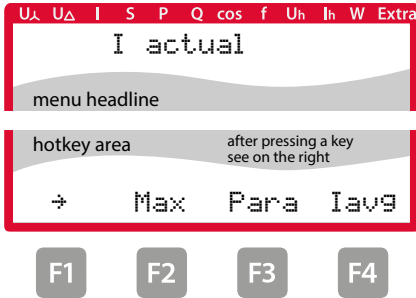

- F1 Scroll through main menu
- F2 Display and processing of minimum and maximum values
- F3 Configuration => limits and current transformer and voltage transformer
- F4 Continue to submenu current – average

6.3.1 Submenu Im current average

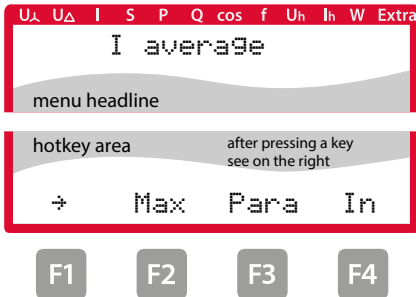

- F1 Scroll through main menu
- F2 Display and processing of minimum and maximum values
- F3 Configuration of limits and Im average value time
- F4 Continue to neutral conductor current menu

6.3.2 Submenu In neutral conductor current

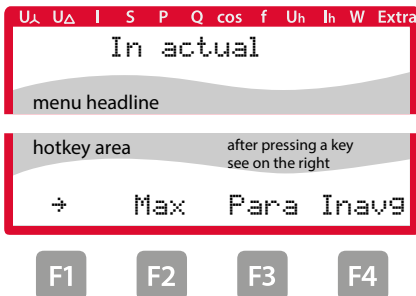

- F1 Scroll through main menu
- F2 Display and processing of minimum and maximum values
- F3 Configuration of limits and current transformer
- F4 Continue to submenu neutral conductor current – average

6.3.3 Submenu Inm average neutral conductor current

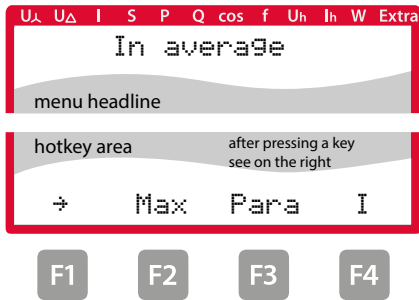

- F1 Scroll through main menu
- F2 Display and processing of minimum and maximum values
- F3 Configuration of limits
- F4 Return to main menu

6.4 Main menu S apparent power

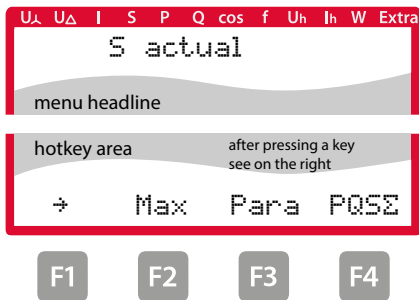

- F1 Scroll through main menu
- F2 Display and processing of minimum and maximum values
- F3 Entry for configuration => limits
- F4 Submenu totals for active, reactive and apparent power

6.4.1 Submenu PQS display of totals for active, reactive and apparent power

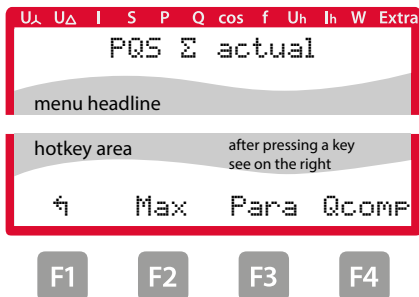

- F1 Return
- F2 Display and processing of minimum and maximum values
- F3 Configuration of limits

6.5 Main menu P active power:

Menu: P instantaneous value

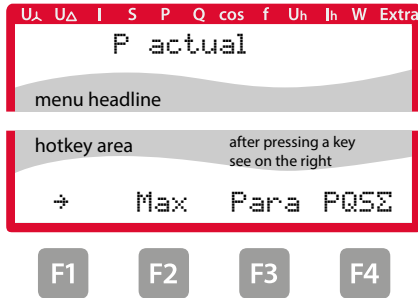

- F1 Scroll through main menu
- F2 Display and processing of minimum and maximum values
- F3 Configuration => limits
- F4 Submenu totals for apparent, active and reactive power

6.5.1 Submenu PQS display of totals for apparent, active and reactive power

For a description, see limit “Submenu PQS display of totals for apparent, active and reactive power”.

6.6 Main menu Q reactive power (fundamental)

Menu: Q1 instantaneous value

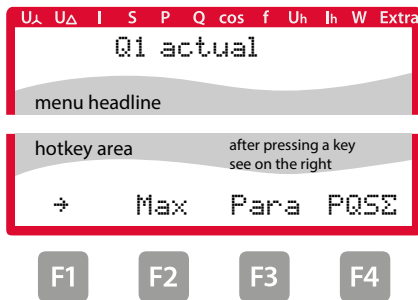

- F1 Scroll through main menu
- F2 Display and processing of minimum and maximum values
- F3 Entry for configuration => limits
- F4 Submenu totals for apparent, active and reactive power

6.6.1 Submenu PQS display of totals for apparent, active and reactive power

For a description, see limit “Submenu PQS display of totals for apparent, active and reactive power:”

6.7 Instantaneous value Cos Phi

Menu: $\cos\varphi$ instantaneous value

- F1 Scroll through main menu
- F2 Display and processing of minimum and maximum values
- F3 Entry for configuration => limits
- F4 Submenu power factor

6.7.1 Submenu power factor

- F1 Return
- F2 Display and processing of minimum and maximum values
- F3 Configuration of limits
- F4 Submenu power factor, total

6.7.2 Submenu totals of power factors

- F1 Return
- F2 Display and processing of minimum and maximum values
- F3 Configuration of limits
- F4 Return to main menu

6.8 Main menu F frequency

Menu: F instantaneous value

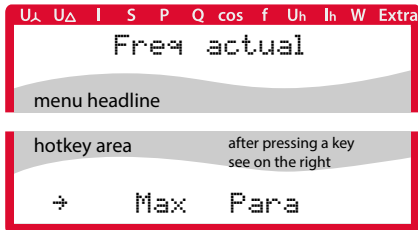

- F1** Scroll through main menu
- F2** Display and processing of minimum and maximum values
- F3** Entry for configuration => limits



6.9 Main menu U_h voltage distortion factor

Menu: U_h instantaneous value as a graphic



F1 Scroll through main menu

F4 Continue to values and individual harmonics

6.9.1 Submenu 3rd harm. U

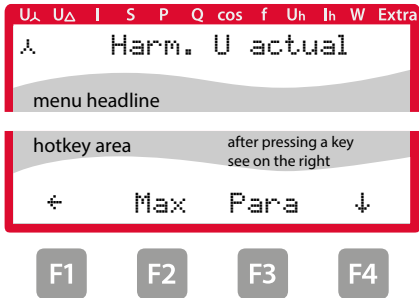

F1 Back to main menu

F2 Display and processing of maximum values

F3 Entry for configuration => limits

F4 Continue to next harmonic oscillation



NOTE

Display up to 19th harmonic same as for 3rd harmonic.
13. harm. to 19th harm. without limits, 21th to 63th harm. only instantaneous values

6.10 Main menu I_h distortion current strength

Menu: I_h instantaneous value as a graphic



F1 Scroll through main menu

F4 Continue to values and individual harmonics

6.10.1 Submenu 3rd harm. I

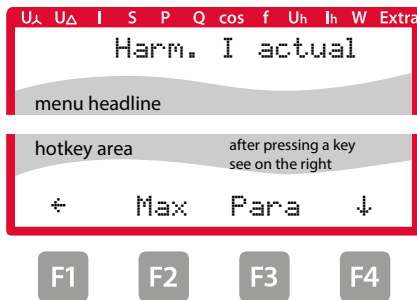

F1 Back to main menu

F2 Display and processing of maximum values

F3 Entry for configuration => limits

F4 Continue to next harmonic oscillation



NOTE

Display up to 19th harmonic same as for 3rd harmonic.
13. harm. to 19th harm. without limits, 21th to 63th harm. only instantaneous values

6.11 Main menu W - active and reactive energy / consumption and recovery

Menu: W active and reactive energy



F1 Scroll through main menu



F3 Entry for configuration
=> tariff and synchronization

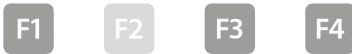

F4 Submenu active energy
low tariff consumption

6.11.1 Submenu W active energy low tariff consumption

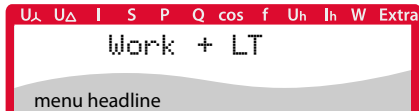

F1 Return



F3 Entry for configuration
=> limits

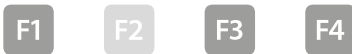

F4 Submenu reactive energy
high tariff consumption

6.11.2 Submenu W reactive energy high tariff consumption

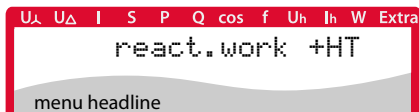

F1 Return



F3 Entry for configuration
=> tariff and synchronization

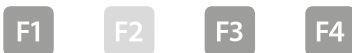

F4 Submenu reactive energy
low tariff consumption

6.11.3 Submenu W reactive energy low tariff consumption

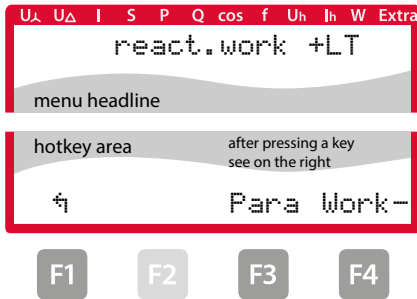

F1 Return

F3 Entry for configuration
=> tariff and synchronization

F4 Submenu active energy
high tariff recovery

6.11.4 Submenu W active energy high tariff recovery

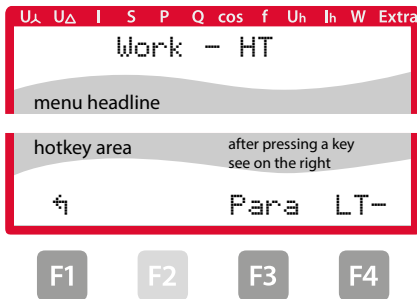

F1 Return

F3 Entry for configuration
=> tariff and synchronization

F4 Submenu active energy
low tariff recovery

6.11.5 Submenu W active energy low tariff recovery

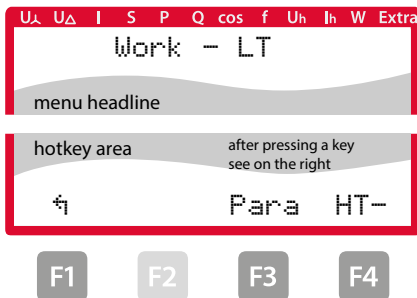

F1 Return

F3 Entry for configuration
=> tariff and synchronization

F4 Submenu reactive energy
high tariff recovery

6.11.6 Submenu W reactive energy high tariff recovery

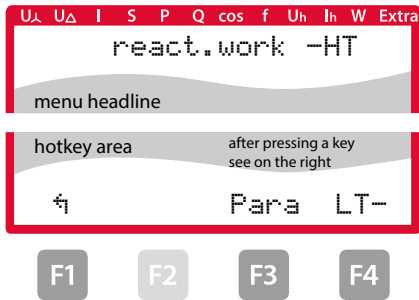

F1 Return

F3 Entry for configuration
=> tariff and synchronization

F4 Submenu reactive energy
low tariff recovery

6.11.7 Submenu W reactive energy low tariff recovery

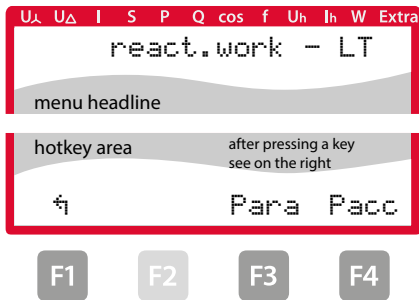

F1 Return

F3 Entry for configuration
=> tariff and synchronization

F4 Display of maximum
active energy of the period consumption

6.11.8 Submenu W maximum active energy of the period

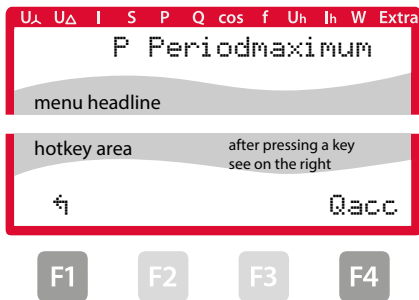

F1 Return

F4 Display of maximum
reactive energy of the period consumption

6.11.9 Submenu Q maximum reactive energy of the period

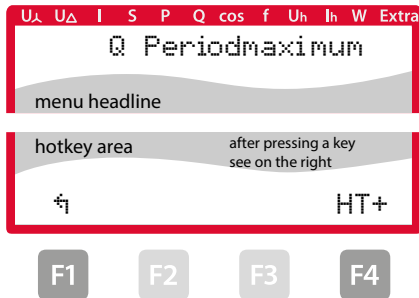

F1 Return

F4 Return to main menu

6.12 Main menu Extras

Firmware information

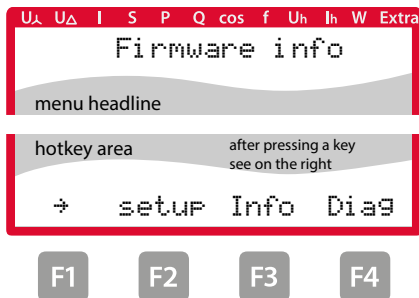

F1 Scroll through main menu

F2 Device configuration

F3 Message

F4 Diagnosis for measuring voltage dip, available after voltage dip only

In versions option 6 and 7, the device can record measuring voltage dips. They can be displayed calling up the Diag (F4) menu item in the Extras window.

Configuration of this function is only possible with the visual energy computer software.

The measuring voltage dips recorded are not saved and are deleted in case of a power failure.

6.12.1 Setting transformer ratio

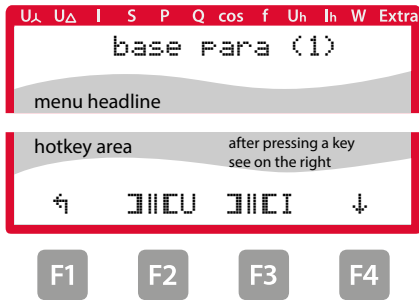

- F1 Return
- F2 Voltage transformer ratio configuration
- F3 Current transformer ratio configuration
- F4 Continue with basic para (2)

6.12.2 Time and bus communication

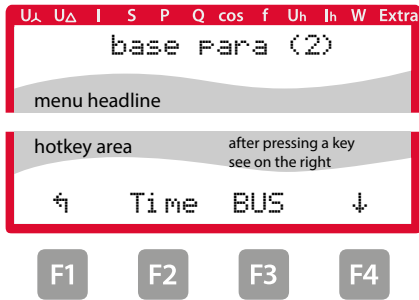

- F1 Return
- F2 Set time (time, date, daylight saving time)
- F3 Set bus parameters (baud rate, address, protocol etc.), see attachment
- F4 Continue with basic para (3)

6.12.3 Set display and attenuation coefficient

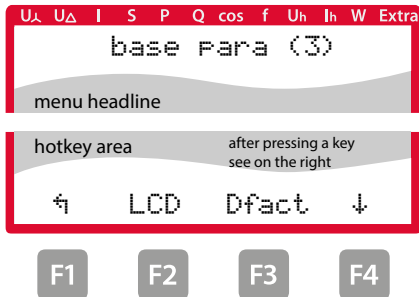

- F1 Return
- F2 Brightness, color adjustment, display test, dimmer
- F3 Set attenuation coefficient for current and voltage
- F4 Continue with basic para (4)

6.12.4 Set language and pulse output

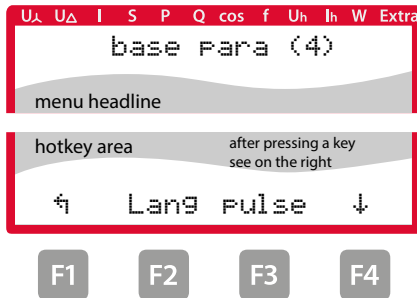

- F1 Return
- F2 Set user language (German / English)
- F3 Configure pulse output
- F4 Continue with basic para (5)

6.12.5 Configure relay outputs

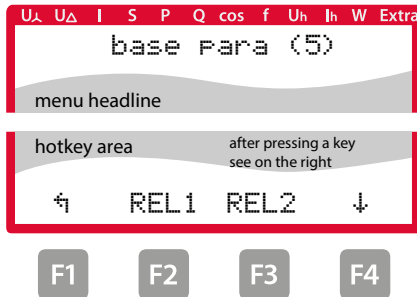

- F1 Return
- F2 Configure relay output 1
- F3 Configure relay output 1
- F4 Continue with basic para (6)

6.12.6 Password and reset

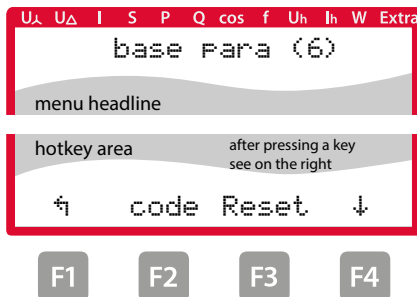

- F1 Return
- F2 Password entry / password protection
- F3 Reset limits, extreme values, meters or reset to default settings
- F4 Continue with basic para (7)

6.12.7 Zero-point creator

Configuration as described below:

U_Δ U_Δ | S P Q cos f U_h I_h W Extra

base Para (7)

menu headline

hotkey area after pressing a key see on the right

← Zero. ↓

F1 F2 F3 F4

- F1 Return
- F2 Default menu Start (selection)
- F3 Activate/deactivate zero-point creator:
- F4 Continue with basic para (1)

After pressing the **F3** (EDIT) button, the following is displayed in the hot key area:

U_Δ U_Δ | S P Q cos f U_h I_h W Extra

zero Point creat

menu headline

hotkey area after pressing a key see on the right

← EDIT

F1 F2 F3 F4

- F1 Return
- F4 Activation and selection zero-point creator on/off

After pressing the **F4** (EDIT) button, the following is displayed in the hot key area:

U_Δ U_Δ | S P Q cos f U_h I_h W Extra

Zero Point creat

menu headline

hotkey area after pressing a key see on the right

NO YES ?

F1 F2 F3 F4

- F1 Discard changes
- F2 Confirm and save settings
- F4 Selection off / on

After confirming to save your settings by pressing **F2** and returning with the **F1** (↶) button, the following is displayed in the hot key area:

The screenshot shows a menu interface with a red border. At the top, a row of characters is visible: U_Δ, U_Δ, I, S, P, Q, cos, f, U_h, I_h, W, Extra. Below this, the text 'base para (7)' is displayed. A grey bar below contains the text 'menu headline'. The next section is labeled 'hotkey area' and contains the text 'after pressing a key see on the right'. Below this, the text 'Zero.' is shown with a left arrow (↶) and a right arrow (↷). At the bottom, four function key buttons are shown: F1, F2, F3, and F4.

- F1** Return
- F2** Default menu Start (selection)
- F3** Activate/deactivate zero-point creator:
- F4** Continue with basic para (1)

6.13 Reset to default settings

Reset should only be carried out during setup and when the device is completely reprogrammed.



CAUTION

Reset will reset all programmed values to their default settings!!!

Reset is carried out in the menu **Extras - sub menu Reset / Default settings**.

The device is reset to its default settings, i.e. all stored data is lost!

This includes all operating parameters, limits and extreme values as well as the off-delay of the signaling relays.

The memory for limit violations is deleted.

The settings for time, date and bus address are not affected by a reset.



CAUTION

Check all operating parameters for correctness!

7 Technical data in multimes F96 TFT-...-5

7.1 Measuring and display values

Wave form for U and I		any
Voltage	RMS value of a measurement interval	Phase - N: $U_{L1-N}; U_{L2-N}; U_{L3-N}$ / phase - phase: $U_{L1-2}; U_{L2-3}; U_{L3-1}$
	Units	[V, kV] display switches automatically
	Measuring range	0.00kV to 999.9 kV
Current (apparent current)	RMS value of a measuring interval	$I_{L1 Inst}; I_{L2 Inst}; I_{L3 Inst}$ instantaneous value for each phase
	Average value determination	$I_{L1 Av}; I_{L2 Av}; I_{L3 Av}$; floating average value from RMS values over a configurable period of time
	Units	[A;kA;MA]; display switches automatically
	Measuring range	0.00A to 999.9 kA
Neutral conductor	RMS value of a measuring interval	$I_{N Inst} / I_{N Avg}$ instantaneous and average value
	Units	[A;kA;MA]; display switches automatically
	Measuring range	0.00A to 1.2 MA
Frequency	Power frequency measurement	f_{mains} ; measured with power supply correction
	Units	[Hz]
	Measuring range	45 ... 65 Hz
Apparent power	Calculation	$S_{L1}, S_{L2}, S_{L3}, S_{tot}$
	Units	[VA; kVA; MVA] display switches automatically
	Measuring range	0.00VA to 999MVA
Active power	Calculation	$P_{L1}, P_{L2}, P_{L3}, P_{total}$
	Units	[W; kW; MW] display switches automatically
	Measuring range	0.00W to 999MW

Reactive power	Calculation -> ind. and cap.	$Q_{L1}, Q_{L2}, Q_{L3}, Q_{total}$; distinction between ind./cap.
	Units	[Var; kvar; Mvar]; display is switched automatically.
	Measuring range	0.00VAR to 999Mvar
Power factor	Calculation -> ind. and cap.	$\cos\varphi_{L1}; \cos\varphi_{L2}; \cos\varphi_{L3}; LF_{L1}; LF_{L2}; LF_{L3}; LF_{tot.}$; distinction between ind./cap. $\cos\varphi$ in the display
	Measuring range	CosPhi 0.1 ind. $\leftarrow 1 \rightarrow$ 0.1 cap., LF 0.1 - 1
Active energy	Calculation	W (HT/LT); $P_{average}$ max. of a measurement period
	Units	[Wh; kWh; MWh]; display is switched automatically
	Measuring range	0.0kWh to 9999999999.9kWh
Reactive energy	Calculation	Wq (HT/LT) ind. or cap.; $Q_{average}$ max. of a measuring period
	Units	[varh; kvarh; Mvarh]; display switches automatically
	Measuring range	0.0kvarh to 9999999999.9kvarh
Harmonics	Distortion factor (THD) for voltage	Voltage: DF- U_{L1} ; DF- U_{L2} ; DF- U_{L3} ;
	Partial distortion factors	3 rd ; 5 th ; 7 th ; 9 th ; 11 th ; 13 th ; 15 th ; 17 th to 63 rd Harmonics of the voltage
	Units	[%]
	Measuring range	0.00% to 100%
harm. Harmonics of the current	Current harmonics	3 rd ; 5 th ; 7 th ; 9 th ; 11 th ; 13 th ; 15 th ; 17 th to 63 rd harmonic for each phase
	Total of current harmonics	Current: I_{L1} ; I_{L2} ; I_{L3} ; for each phase separately
	Units	[A]
	Measuring range	0.00A to 999.9kA

7.2 Measurement accuracy class (in accordance with DIN EN 61557-12)

Measured value	Symbol	Accuracy class
Voltage	U_{PHN}	0.5 / ± 1 digit
Voltage	U_{PHPH}	0.5 / ± 1 digit
Phase current	I	0.5 / ± 1 digit
Neutral conductor current calculated	I_{NC}	2 / ± 1 digit
Power factor	PF_A	1 / ± 1 digit
CosPhi of the fundamental components		1 / ± 1 digit
Frequency	f	0.02 / ± 1 digit
Total apparent power	S_A	1 / ± 1 digit
Total active power	P	1 / ± 1 digit
Total reactive power	E_a	1 / ± 1 digit
Total reactive power fundamental components	Q_a	1 / ± 1 digit
Total reactive energy consumption and recovery	Q_a	1 / ± 1 digit
Voltage harmonics	U_h	1 / ± 1 digit
THD of the voltage	THD- R_U	1 / ± 1 digit
Current harmonics	I_h	1 / ± 1 digit

7.3 Measuring principle

Sampling	205 measuring points per period (50 Hz) 170 measuring points per period (60 Hz)
A/D converter	16 bit
Measurement of U and I	simultaneous recording of measured values for U and I;
Update speed	Display ~ 500 ms
Harmonics calculation	FFT with 2048 points over 10 periods (50 Hz) FFT with 2048 points over 12 periods (60 Hz)
Frequency measurement	Consumption: Voltage measured between phase L1, L2, L3 - N;

7.4 Device memory

Work, data & parameter memory		2 MB flash
Program memory		512 kB flash
Memory type		Ring buffer
Long-term memory (1 year)		Daily values for active and reactive energy (HT and LT) for consumption and recovery
Period memory for 1464 / 732 / 366 / 24 days		60 / 30 / 15 / 1 minute - values of: Active energy, reactive energy (each consumption and recovery)
Extreme values (max./min.)		Extreme values that occurred after connection to the power supply or after the extreme value memory has been deleted manually including date and time
Event memory	Memory size	1500 events including date and time of their occurrence
Operation logbook	Memory size	500 events including date and time of their occurrence
Limit violations:	Recording time	≥ 200 ms
Measuring voltage dips:	Recording time	≥ 20 ms; threshold can be set using the computer, value after reset 85% of rated voltage (according to EN 61000-4-30).

7.5 Power supply

Power supply	US1: 100 to 240V +/- 10% AC/DC 50/60 Hz; 8VA, 4W US5: 22.5 to 64V +/- 10% AC/DC 50/60 Hz; 8VA, 4W
--------------	--



NOTE

To protect your purchased high-quality devices from damage, we strongly recommend that you take overvoltage protection measures. Protect control voltage inputs, pulse and bus lines.

Systems that are at risk from lightning strikes must feature lightning protection for all input and output lines.

7.6 Hardware inputs and outputs

7.6.1 Hardware inputs

Voltage measurement inputs	$U_{L1-L2}; U_{L2-L3}; U_{L3-L1}$	3 x 5V... 100V ...120V AC (measuring range 1) 3 x 20V... 500V ...600V AC (measuring range 2)
	Input impedance	1.2 MOhm (Ph-Ph)
	Measuring range	Can be configured using voltage transformers
Current measuring input		3 x 0.01A... 1A ...1.2A AC (measuring range 1) 3 x 0.05A... 5A ...6A AC (measuring range 2)
	Power consumption	≤ 0.3VA per input at 6A
	Measuring range	Can be configured using current transformers

7.6.2 Hardware outputs

Signaling relay for limit violations (optional)	Number	2
	Contact	floating
	Reaction speed	programmable, 0 to 254 seconds
	Switching capacity	250V AC / 2A;
Pulse output	Output type	Active and reactive energy 0.001 to 9990 pulses per KWH or kvar
	Optocoupler output	15 mA at max. 35 V; S_0 -compatible
	Accuracy class	2
	Pulse length	Programmable, 30 to 990 ms
	Power supply	external
Interface (option)	BUS	RS485 for connection to the KBR eBus or Modbus; max. 32 devices, up to 1000 devices with bus repeater
	Baud rate	38400 fixed at KBR eBus, configurable with Modbus
	Address assignment	Can be addressed automatically with software or manually on the device up to address 9999. For Modbus: 1 to 247 manually on the device.
	LAN	IEEE 802.3
	speed	10 Mbit / 100 Mbit
	Connection	IEEE 802.3 10base-t / 10base-TX, cable CAT5

7.7 Electrical connection

Connection elements		Screw terminals
Permissible cross-section of the connecting cables		2.5 mm ²
Measurement voltage inputs	Fuse	max. 1 A slow-blow max. C2 automatic isolating switch UL/IEC-approved
Measuring current inputs	Fuse	NONE!!! Always short-circuit current transformer terminals k and l before opening the circuit!
Input control voltage	Fuse	max. 1 A slow-blow max. C2 automatic isolating switch UL/IEC-approved
Relay output	Fuse	max 2A medium time-lag
BUS connection	Connection material	For proper operation, please only use shielded twisted-pair cables; e.g. I-Y-St-Y 2x2x0.8
Pulse output	Connection and cables	Observe correct polarity! For proper operation, please only use shielded twisted-pair cables; e.g. I-Y-St-Y 2x2x0.8
Transformer connection	Connections	See connection diagram
Interfaces Connection	RS485 BUS connector pins	Terminal 90 (L) Terminal 91 (A) Terminal 92 (B)

7.8 Mechanical data

Switch-board installation	Housing dimensions	96 x 96 x 65 mm (H x W x D)
	Installation cut-out	92 x 92 mm
	Weight	min. 300g, max. 350g, depending on optional board

26195_EDBD0A0297-0921-1_EN

7.9 Standards and miscellaneous

Ambient conditions	Standards	DIN EN 60721-3-3:1995-09 + DIN EN 60721-3-3/A2:1997-07; 3K5+3Z11; (IEC721-3-3;3K5+3Z11)	
	Operating temperature	K55 (-5°C +55 °C)	
	Air humidity	5% 95% non-condensing	
	Storage temperature	K55 (-25°C +70°C)	
	Operating height	0...2,000 m above sea level	
Electrical safety	Standards	DIN EN 61010-1:2011-07; DIN EN 61010-2-030:2011-07	
	Protection class	I	
	Overvoltage category, measurement category	Voltage measurement: Current measurement: Power supply:	CAT III: 300 V; CAT II: 400 V CAT III: 300V CAT III: 300V
	Rated surge voltage	4kV	
Protection type	Standards	DIN EN 60529:2014-09	
	Front	IP 40, with IP 51 seal	
	Terminals	IP 20	
EMC	Standards	DIN EN 61000-6-2:2006-03 + amendment 1:2011-03 DIN EN 611326-1:2013-07 Devices without Profibus DP DIN EN 61000-6-3:2011-09 + amendment 1:2012-11 Devices with Profibus DP DIN EN 61000-6-4:2011-09	
Synchronization	Type	internal, tariff switching or by KBR eBus	
Synchronization time		With internal synchronization based on the full hour	

7.10 Default settings after a reset (delivery state)

Primary voltage/secondary voltage	400 V/400 V
Primary current/secondary current	5 A/5 A
Zero-point creator	off
Measurement period time	15 minutes
Current average time	10 minutes
Daylight saving time	from month 03 to 10
Frequency correction	automatic
Tariff switching	via KBR eBus
Low tariff time	programmed time for internal switching of HT and LT: 22:00 - 6:00 (10pm to 6am)
Language	Germ. (German text display)
Attenuation coefficient for current and voltage	DF 0 (no attenuation)
Energy pulse	P (active power for consumption), 1 (1,000) pulse /kWh, pulse length 100 ms
Alarm relay	On delay tON = 0 sec Off delay tOFF = 0 sec
Measurement period synchronization	Internal
Password	9999/all functions can be accessed
Button buzzer (volume)	activated, 50%
Limit hysteresis	01 %
Default menu Start selection	Deactivated

Unaffected by a RESET:

1. Bus communication
2. Time
3. Language

8 Modbus interface



NOTE

Availability of data points depends on the device version.

8.1 Description Modbus interface for Modbus RTU or ASCII

The multimes F96 TFT-xxx-5 is optionally available with a Modbus RTU or ASCII interface. In order to use these, the device has to be converted from the KBR eBus to the Modbus RTU or ASCII bus protocol.

To do so, proceed as follows:

Main menu Extra

Firmware information				Menu heading
F1	F2	F3	F4	
→	Setup	Mes.		Display hot-key area
		Messages about limit violations		
	Device configuration menu			
Scroll through main menu				

Press the **F2** and then the **F4** button.

8.1.1 Change bus protocol

Basic para (2)				Menu heading
F1	F2	F3	F4	
←	Time	Bus	+	Display hot-key area
		Other basic para (3)		
	Set bus parameters (baud rate, address, protocol etc.)			
	Set time (time, date, daylight saving time)			
Return				

After confirmation with the **F3** button, the following display appears:

Bus parameters				Menu heading
F1	F2	F3	F4	
↵		eBus	EDIT	Display hot-key area
				Change bus protocol (Modbus, eBus)
		Set Ebus parameters (address)		
Return				

Start the entry with the **F4** button and then change the bus protocol with **F3** by switching from KBR eBus to Modbus.

Basic para (2)				Menu heading
F1	F2	F3	F4	
NO	YES	Lösch	EDIT	Display hot-key area
				Selecting the Modbus bus protocol
		Delete entry		
	Save changes			
Discard changes				

Subsequently, save the changes with **F2** or discard them with **F1**. The device reboots and accepts the new configuration.

Bus parameters				Menu heading
F1	F2	F3	F4	
↵		ModB	EDIT	Display hot-key area
				Selecting the bus protocol (eBus or Modbus)
		Call up Modbus settings		
Return				

Use the **F3** button to call up the Modbus settings.

ModBus settings				Menu heading
F1	F2	F3	F4	
↩			EDIT	Display hot-key area
			Configuring the Modbus bus protocol	
Return				

By pressing **F4**, call up the settings menu for the Modbus address and bus protocol.

The following protocols can be set:

4.8k Baud, 9.6k Baud, 19.2k Baud with the respective parity even / odd or no Parity in Modus RTU or ASCII.



NOTE

The default setting of the Modbus transmission in mode RTU and ASCII is 19.2 kBaud, even parity, 8 data bits, 1 stop bit.

8.2 Ethernet interface for Modbus TCP

The multimess F96 TFT-xxx-5 is optionally available with an interface for Modbus TCP.

Main menu Extra

Firmware information				Menu heading
F1	F2	F3	F4	
→	Setup	Mes- sage		Display hot-key area
				Messages about limit violations
				Device configuration menu
Scroll through main menu				

Press the **F2** and then the **F4** button.

8.2.1 Change bus paramters

Basic para (2)				Menu heading
F1	F2	F3	F4	
←	Time	Bus	↓	Display hot-key area
				Other basic para (3)
				Set bus parameters (IP address, netmask (host))
				Set time (time, date, daylight saving time)
Return				

Press the key **F3**.

Bus parameters				Menu heading
F1	F2	F3	F4	
←		IPadr		Display hot-key area
				Display / entry IP address and netmask (host)
Return				

By pressing **F3**, call up the settings menu for the IP address and netmask. When entering the netmask, observe the following chart:

Network class	Host bits	Netmask
A	24	255.0.0.0
B	16	255.255.0.0
C	8	255,255,255.0

The default setting is 8 bit (255.255.255.0)

8.3 Modbus TCP configuration via Ethernet interface (Telnet)

The Modbus TCP interface of the multimes F96 TFT-xxx-5 can be set up using the Ethernet interface via Telnet.

Start the Telnet program:

telnet <IP address> <port number>

with the known device IP address as <IP address>

and the configuration port number of the device (always 9999) as <port number>.

Example: telnet 10.66.22.98 9999

If device and computer are part of the same network, the device displays the following text:

```
Modbus/TCP to RTU Bridge
MAC address 00204A840B45
Software version 02.2b1 (040728) XPTEX
Press Enter to go into Setup Mode
```

With the return key, open the configuration menu.

Model: Device Server Plus+! (firmware code:XA)

Modbus/TCP to RTU Bridge Setup

1) Network/IP Settings:

IP Address 10.66.22.98

Default Gateway --- not set ---

Netmask 255,255,255,000

2) Serial & Mode Settings:

Protocol Modbus/RTU, Slave(s) attached

Serial Interface 19200,8,E,1,RS485

3) Modem/Configurable Pin Settings:

CP1 RS485 Output Enable

CP2 Not Used

CP3 Not used

4) Advanced Modbus Protocol settings:

Slave Addr/Unit Id Source .. Modbus/TCP header

Modbus Serial Broadcasts ... Enabled (Id=0 used as broadcast)

MB/TCP Exception Codes Yes (return 00AH and 00BH)

Char, message Time-out 00010msec, 00200msec

D)efault settings, S)ave, Q)uit without save

Select Command or parameter set (1..4) to change:

You can change the settings and save them by pressing S. The device can now be operated using the new parameters.

9 Ethernet interface for eBus TCP

The multimess F96 TFT-xxx-5 is optionally available with an interface for eBus TCP.

Main menu Extra

Firmware information				Menu heading
F1	F2	F3	F4	
→	Setup	Mes- sage		Display hot-key area
		Messages about limit violations		
	Device configuration menu			
Scroll through main menu				

Press the **F2** and then the **F4** button.

9.1.1 Change bus protocol

Basic Para (2)				Menu heading
F1	F2	F3	F4	
←	Time	Bus	→	Display hot-key area
		Other basic para (3)		
	Set bus parameters			
	Set time (time, date, daylight saving time)			
Return				

After confirmation with the **F3** button, the following display appears:

Basic para (2)				Menu heading
F1	F2	F3	F4	
↶	Time	LAN	↷	Display hot-key area
		Call up LAN settings		

Use the **F3** button to call up the LAN settings.

LAN settings				Menu heading
F1	F2	F3	F4	
↶	SCAN	IPadr	EDIT	Display hot-key area
		Selecting the bus address		
		Display / entry IP address and netmask (host)		
	SCAN address is activated (for automatic eBus address assignment)			
Return				

By pressing **F3**, call up the settings menu for the IP address and netmask.

9.2 KBR eBus TCP configuration using the display

On the display, you can display and change the IP address in the menu item LAN and the subnet mask in the menu item Host.

On delivery, the devices are set to the IP address 192.168.0.1. This IP address is also shown in the display.

For this reason, it is recommended to check whether the device can be reached using this IP address.

When entering the netmask, observe the following chart:

Network class	Host bits	Netmask
A	24	255.0.0.0
B	16	255.255.0.0
C	8	255,255,255.0

The default setting is **8** bit (255.255.255.0)

9.3 KBR eBus TCP configuration (software configuration)

After installing and starting the IOT Service Tool, the connected network is scanned and the e-ports found are displayed, and can be further processed.

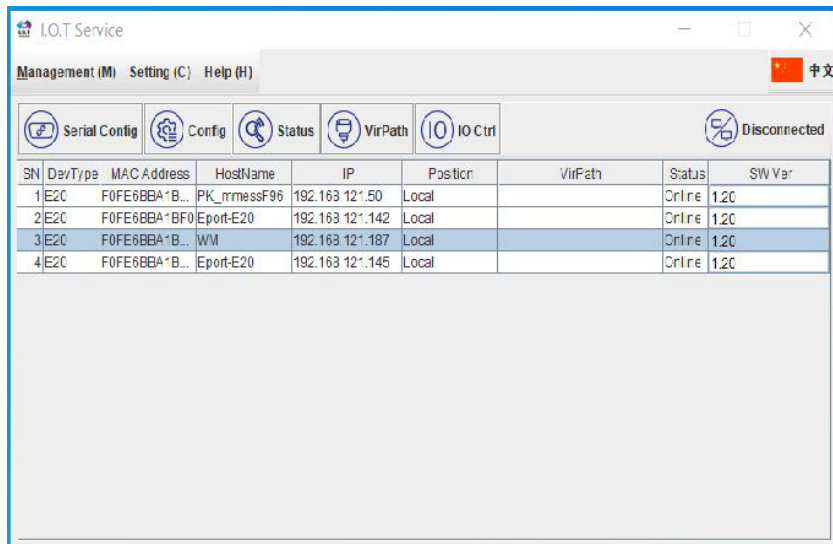

After selecting the e-port, click on "Config" to access the configuration settings.



NOT

The default settings are configured on the KBR eBus. If Modbus is used, proceed as described in item 8.3.

9.3.1 Assigning an IP Address to a Device of which the Address is Not in the Address Range of the Network.

In the main window of the IOT Service Tool, open the 'BroadCast Scan' window via **Setting (C) -> BroadCast**.

SN	DevType	MAC Address	IP
1	E20	F0FE6BBA1BEB	192.168.0.1

E-port devices that are in the network but do not have a valid network address are listed here.

Double-click on the row with the device in it to open the "Fast Setting" window:



NOTE

A valid IP address and the subnet mask can be entered here. Click "Confirm" to apply the settings.

The device should then appear in the list in the main 'IOT Service' window.

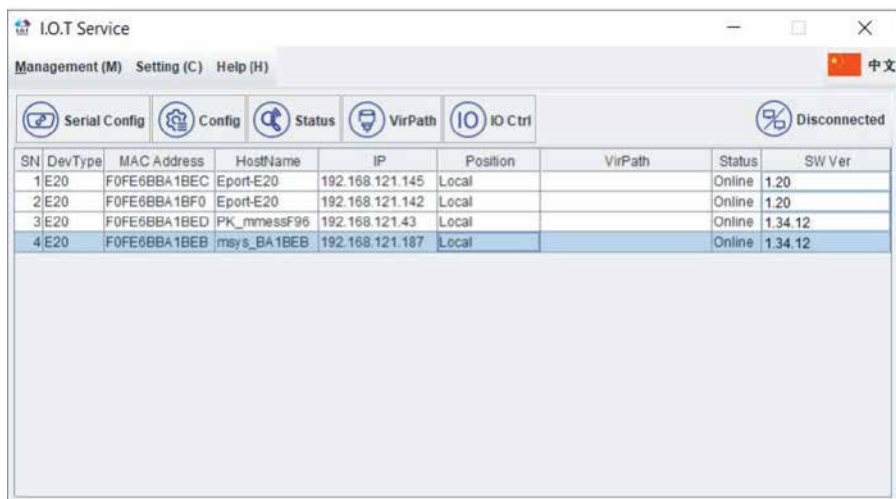

After selecting the e-port, click on "Config" to access the configuration settings.

9.3.2 E-port Configuration for eBus TCP

For eBus TCP, the parameters must be set as shown in the figure below. The network parameters (IP address, mask, gateway, DNS) must be adapted to local circumstances.



NOTE

“Flow Control: Half Duplex” controls the changeover of the RS485 component. The web port must be set to 8000. Click „Confirm” to apply the parameters

When “Detail” is selected, this window appears:

The screenshot shows the 'Setup Detail' window with the following configuration:

- System:**
 - Telnet: **Enable**
 - Telnet Port: 23
 - Telnet Echo: **Enable**
 - Embedded Web: **Enable**
 - Web Port: 80
 - NTP: **Disable**
 - NTP Server: (empty)
 - NTP Port: 123
 - NTP GMT: 0
- WiFi Roaming:**
 - WiFi Roaming: **Disable**
 - Scan RSSI Threshold: 50
 - Connect RSSI Threshold: 70
- UART:**
 - UART No: **UART 1**
 - UART Protocol: **NONE**
 - Frame Length: 16
 - Frame Time: 100
 - Tag Enable: **Disable**
 - Tag Start: 0
 - Tag End: 0
 - SWFlow Control: **Disable**
 - Xon: 11
 - Xoff: 13
 - Cli Get: **Serial-String**
 - Serial-String: +++
 - Cli Wait Time: 15
 - Gap Time: 10
- SOCKET:**
 - SOCKET Name: **netp**
 - Security: **Disable**
 - Security Key: (empty)
 - Connect Mode: **Always**
 - Stop Serial: (empty)
 - HeartBeat: **Disable**
 - HeartBeat Time: (empty)
 - HeartBeat Serial: ... (empty)
 - Regist Mode: **Disable**
 - Regist Code: ... (empty)
 - Max Client NumMax C...: 5

Buttons at the bottom: Edit Script, Confirm, Cancel.



HINWEIS

- For eBus TCP, the UART protocol must be set to “NONE”
- The gap time should be set to 10 (ms).
(This is the waiting time after serial reception, until a telex message is sent via the network).
- Cli waiting time should be set to max. 15 (seconds).

10 Data point description for the Modbus protocol

10.1 Supported Modbus commands

0x02	Read Discrete Inputs
0x04	Read Input Registers
0x06	Write Single Input Register
0x10	Write Multiple Registers
0x2B	Read Device Identification

The Multimes Comfort does not support broadcast commands. All Modbus commands described are device-specific commands.

10.2 Data formats

(unsigned) short: 0x1234

Address	+0	+1
Contents	0x12	0x34

Rule for byte sequence: MSB before LSB

(unsigned) long: 0x12345678

Address	+0	+1	+2	+3
Contents	0x12	0x34	0x56	0x78

Rule for byte sequence: MSB before LSB

float:

Format	Complies with the IEEE 754 standard
Representation	4 bytes
Accuracy	24 bits (➤ represent >7 decimal points)
Composition	24-bit mantissa; 8-bit exponent
Mantissa	24 bits (M) + 1 bit (S) The MSB of the mantissa is always 1 => it is not saved separately! S = sign of the mantissa: S = 1 ➤ negative number; S = 0 ➤ positive number
Exponent	8 bits (0-255); is saved relatively to 127, i.e. the current value of the exponent is calculated by subtracting the number 127 from the saved value. Curr. exp. = saved exp value. - 127 => range of numbers from 128 to -127!

Example 1: -12.5 decimal = 0xC1480000 hex

M: 24 bit-mantissa

E: Exponent with offset of 127

S: Sign for mantissa (S=1 neg.; S=0 pos.)

Address	+0	+1	+2	+3
Format	SEEEEEEE	EMMMMMMM	MMMMMMMM	MMMMMMMM
Binary	1 1 0 0 0 0 0 1	0 1 0 0 1 0 0 0	0 0 0 0 0 0 0 0	0 0 0 0 0 0 0 0
Hex	C1	48	00	00

The byte sequence is defined as follows:

The byte with the "S sign bit" is transmitted over the bus as the first byte.

The sequence of the float bytes of the bus can be reversed, if necessary, using the device parameter 0xD02C (see table 1).

The register value 0xD02C in this case means:

- with 1 -> sign bit S in 1st byte (sequence according to definition)
- with 0 -> sign bit S in 4th byte (sequence reversed)

The following information can be derived from this:

The sign bit is 1 => negative mantissa

The value of the exponent amounts to 10000010 bin or 130 dec.

This results in an exponent value of: $130 - 127 = 3$

The mantissa has the following value: 1001000000000000000000

The decimal point can be found at the left end of the mantissa, preceded by a 1. This position does not appear in the hexadecimal numeric notation. If you add 1 and set the decimal point at the beginning of the mantissa, the following value is obtained:

1.1001000000000000000000

Now, the mantissa needs to be adjusted to the exponent. A negative exponent shifts the decimal point to the left, a positive exponent shifts it to the right. Since the exponent is 3, this is represented as: 1100.10000000000000000000

The number obtained corresponds to the binary floating-point number.

Binary digits to the left of the decimal point result in values > 1. In this example, 1100 bin results in the number 12 dec. $\{(1 \times 2^3) + (1 \times 2^2) + (0 \times 2^1) + (0 \times 2^0)\}$

Binary digits to the right of the decimal point result in values < 1. In this example, .100..... bin results in the number 0.5 dec. $\{(1 \times 2^{-1}) + (0 \times 2^{-2}) + (0 \times 2^{-3}) + (0 \times 2^{-4})\}$

By adding the individual values, 12.5 is obtained. As the sign bit was set, it is a negative value, -12.5. The hexadecimal number 0xC1480000 thus corresponds to -12.5.

Example 2: -12.55155 decimal = 0xC148D325 hex

Address	+0	+1	+2	+3
Format	SEEEEEEE	EMMMMMMMM	MMMMMMMMMM	MMMMMMMMMM
Binary	1 1 0 0 0 0 0 1	0 1 0 0 1 0 0 0	1 1 0 1 0 0 1 1	0 0 1 0 0 1 0 1
Hex	C1	48	D3	25

Example 3: 45.354 decimal = 0x42356A7F hex

Address	+0	+1	+2	+3
Format	SEEEEEEE	EMMMMMMMM	MMMMMMMMMM	MMMMMMMMMM
Binary	0 1 0 0 0 0 1 0	0 0 1 1 0 1 0 1	0 1 1 0 1 0 1 0	0 1 1 1 1 1 1 1
Hex	42	35	6A	7F

Exponent: 10000100 bin = 132 dec.
 ➤ Exp.= 132-127=5

Mantissa: S=0
 ➤ Sign=positive
 01101010110101001111111 bin
 Decimal point added to the first position of the mantissa
 ➤ .0110101011010100111111
 Leading 1 in front of decimal point
 ➤ 1.0110101011010100111111
 Taking exponent into account (=5)
 ➤ 101101.01011010100111111
 To the left of the decimal point: 101101 bin = 25+ 23+ 22+20 =
 45 dec.

To the right of the decimal point: 010110101001111111 bin =
 2-2 + 2-4 + 2-5 + 2-7 + 2-9 + 2-12 + 2-13 + 2-14 + 2-15 + 2-16 + 2-17 +
 2-18 = 0.3540001 dec.
Final result: +45.03540001 dec.

Timestamp time_t (is transmitted as unsigned long)

The timestamp describes a point in time. The value is defined as follows: Seconds since 1/1/1970 0^{oo} hours (with respect to the corresponding time zone)

The values are transmitted over the bus as unsigned long (for byte sequence, see above). All values are to be interpreted as standard time (winter time), i.e. if you want to set the device clock in Germany to 11 o'clock in May, then the setting command via the bus must be done, by definition, with winter time 10 o'clock.

The following applies:

All timestamps which are transmitted via the bus are to be interpreted as standard time (winter time).

The device itself must be parametrized according to country-specific parameters. Possible settings here are:

e.g. Germany -> daylight saving time from end of March to end of October

e.g. China -> daylight saving time not activated

10.3 Interface parameters

Setting options for Modbus RTU

Baud rate (baud)	Parity	Data bits	Stop bits
4800, 9600, 19200	even, odd, none	8	2 for parity none otherwise 1

Setting options for Modbus ASCII

Baud rate (baud)	Parity	Data bits	Stop bits
4800, 9600, 19200	even, odd, none	7	2 for parity none otherwise 1

The number of data bits and stop bits is defined in the Modbus definition.

Baud rates smaller than 4800 baud are possible by definition, but not implemented at the moment. The interface parameters can only be set on the device. (not via the bus).

10.4 Optional boards

Depending on the optional board (Opt.), the device has the following functions:

- **Option 0:** no optional board
- **Option 1:** optional board with Modbus RS485, real-time clock, buffer capacitor, 2x relay outputs
- **Option 2:** optional board with Modbus RS485
- **Option 3:** optional board with KBR eBus RS485, Modbus RS485
- **Option 4:** optional board with Modbus Ethernet, real-time clock, buffer capacitor, 2x relay outputs
- **Option 5:** optional board with Profibus DP, real-time clock, buffer capacitor (unavailable)
- **Option 6:** optional board with KBR eBus Ethernet, real-time clock, buffer capacitor, 2x relay outputs
- **Option 7:** optional board with KBR eBus RS485, Modbus RS485, real-time clock, buffer capacitor, 2x relay outputs
- **Option 8:** optional board with KBR eBus RS485, KBR eBus TCP/IP, 2x relay outputs

10.5 Device settings

Device settings are performed via the Modbus command 0x10 (Write multiple registers) in accordance with table 1. These settings can also be read with the Modbus command 0x04.

Ad- dress	Words	Description	Value	Format
0xD002	2	Measuring voltage primary transformer	1-1000000	unsigned long
0xD004	2	Measuring voltage secondary transformer	1-600	unsigned long
0xD006	2	Primary transformer measuring current	1-1000000	unsigned long
0xD008	2	Secondary transformer measuring current	1 ->1A 5 ->5A	unsigned long
0xD00A	2	Frequency correction	0 automatic 1 50Hz fixed 2 60Hz fixed	unsigned long
0xD00C	2	Average current value, averaging time in min	0-255	unsigned long
0xD00E	2	Attenuation voltage (0-9)	0-9	unsigned long
0xD010	2	Attenuation current (0-9)	0-9	unsigned long
0xD012	2	Synchronization type	0 only by internal clock 1 by external synchronized pulse 2 by bus 3 by tariff change	unsigned long
0xD014	2	Tariff switching	0 by digital input 1 by bus 2 switching times saved in the device	unsigned long
0xD016	2	Switch on low tariff clock time (in minutes per day)	0 to 1440	unsigned long
0xD018	2	Switch off low tariff clock time (in minutes per day)	0.1	unsigned long

Ad- dress	Words	Description	Value	Format
0xD01A	2	0 daylight saving time off, 1 daylight saving time active	0.1	unsigned long
0xD01C	2	Switch standard time → daylight saving time	1 – 12	unsigned long
0xD01E	2	Switch daylight saving time → standard time	1 – 12	unsigned long
0xD020	2	Set continuous counter active energy HT	new value	float
0xD022	2	Set continuous counter active energy LT	new value	float
0xD024	2	Set continuous counter reactive energy HT	new value	float
0xD026	2	Set continuous counter reactive energy LT	New value	float
0xD028	2	Set time	Time as timestamp	unsigned long
0xD02A	2	Factor for default re- sponse times	Default setting 10 corre- sponds to factor 1.0 Factor 1.0 corresponds to >3.5 byte times Factor 2.0 corresponds to >7 byte times 0-255 correspond to factors 0 to 25.5	unsigned long
0xD02C	2	Byte sequence for float on the Modbus	1 according to definition 0 reversed	unsigned long
0xD02E	2	Energy type synchronized pulse or tariff switching	0-63	unsigned long
0xD030	2	Pulse output pulse type	0 proportional to active energy consumption 1 proportional to reactive energy consumption 2 proportional to active energy recovery 3 proportional to reactive energy recovery	unsigned long

Ad- dress	Words	Description	Value	Format
0xD032	2	Pulse output Pulse value	1 to 999999 pulses/kW 0 means no pulse output	float
0xD034	2	Pulse length in ms	30-990 ms in steps of 10	unsigned long
0xD036	2	ON delay relay 1 in s)	0-255	unsigned long
0xD038	2	OFF delay relay 1 in s	0-255	unsigned long
0xD03A	2	ON delay relay 2 in s)	0-255	unsigned long
0xD03C	2	OFF delay relay 2 in s	0-255	unsigned long
0xD03E	2	Analog interface TYPE (not supported)	0 corresponds to 0-20mA 1 corresponds to 4-20mA 2 corresponds to 0-10V 3 corresponds to 2-10V	unsigned long
0xD040	2	Analog interface 1 proportionality (not supported)	ID according to table	unsigned long
0xD042	2	Analog interface 1 maximum value (not supported)	Maximum value corre- sponds to this value	float
0xD044	2	Analog interface 1 minimum value (not supported)	Minimum value corre- sponds to this value	float
0xD046	2	Analog interface 2 proportionality (not supported)	ID according to table	unsigned long
0xD048	2	Analog interface 2 maximum value (not supported)	Maximum value corre- sponds to this value	float
0xD04A	2	Analog interface 2 minimum value (not supported)	Minimum value corre- sponds to this value	unsigned long

Ad- dress	Words	Description	Value	Format
0xD04C	2	Analog interface 3 proportionality (not supported)	ID according to table	unsigned long
0xD04E	2	Analog interface 3 maximum value (not supported)	Maximum value corresponds to this value	unsigned long
0xD050	2	Analog interface 3 minimum value (not supported)	Minimum value corresponds to this value	float
0xD052	2	Set continuous counteractive energy HT recovery	New value	float
0xD054	2	Set continuous counteractive energy LT recovery	New value	float
0xD056	2	Set continuous counter reactive energy HT recovery	New value	float
0xD058	2	Set continuous counter reactive energy LT recovery	New value	unsigned long
0xD05A	2	Relay modes	Bit0: 0: Relay 1 acts as limit relay 1: Relay 1 is operated by bus Bit1: 0: Relay 2 acts as limit relay 1: Relay 2 is operated by bus Bit2..31 not used => should be 0	unsigned long

Table 1

The following table describes the IDs that are used to configure the analog interfaces. The value output is proportional to the measured value selected. **(not supported)**

Value output	ID
OFF	0
U_PH_N_L1_V	1
U_PH_N_L2_V	2
U_PH_N_L3_V	3
U_PH_PH_L1_V	4
U_PH_PH_L2_V	5
U_PH_PH_L3_V	6
IS_L1_A	7
IS_L2_A	8
IS_L3_A	9
IS_MW_L1_A	10
IS_MW_L2_A	11
IS_MW_L3_A	12
S_L1_KVA	13
S_L2_KVA	14
S_L3_KVA	15
P_L1_KVA	16
P_L2_KVA	17

Value output	ID
P_L3_KVA	18
Q_L1_KVAR	19
Q_L2_KVAR	20
Q_L3_KVAR	21
COS_L1	22
COS_L2	23
COS_L3	24
LF_L1	25
LF_L2	26
LF_L3	27
NETWORK FRE- QUENCY_HZ	28
IN_A	29
IN_MW_A	30
P_TOT_KVA	31
Q_TOT_KVA	32
S_TOT_KVA	33
PF_TOT	34

Example Modbus RTU

01 10 D0 1F 00 02 04 42 C9 00 00 EB 60

in which

01	Device address
10	Command
D0 1F	Register 0xD020 continuous counteractive energy consumption HT (in accordance with Modbus definition, the required address must be set to -1 in the request telex)
00 02	Write 2 registers
04	Write 4 bytes
42 C9 00 00	Set to value 100.5
EB 60	CRC code

Response: 01 10 D0 1F 00 02 48 CE

in which

01	Device address
10	Command
D0 1F	Write from register 0xD0020
00 02	2 words written
48 CE	CRC code

Example Modbus ASCII

Request: 3A 30 31 31 30 44 30 30 31 30 30 30 34 30 38 30 30 30 30 30 31 39 30 30 30 30 30
30 31 39 30 46 30 0D 0A

in which

3A	Start telex (colon)
30 31	Device address 0x01
31 30	Command 0x10
44 30 30 31	Set registers 0xD002 to 0xD005 (in accordance with the Modbus definition, the required address must be set to -1 in the request telex)
30 30 30 34	Set 4 registers (primary voltage transformer 2 words and secondary 2 words)
30 38	Write number of bytes (8 bytes)
30 30 30 30 30 31 39 30	Primary voltage transformer 0x190 corresponds to dec. 400 V
30 30 30 30 30 31 39 30	Secondary voltage transformer 0x190 corresponds to dec. 400 V
46 30	LRC code
0D 0A	Telex end (CR LF)

Response:

3A 30 31 31 30 44 30 30 31 30 30 30 34 31 41 0D 0A

in which

3A	Start telex (colon)
30 31	Device address 0x01
31 30	Command 0x10
44 30 30 31	Registers 0xD002 to 0xD005 set
30 30 30 34	4 data bytes written
30 30 30 30	No limit violated with address 4 to 13
	Last 6 bits in byte 00 are without meaning
31 41	LRC code
0D 0A	Telex end (CR LF)

10.6 Commands

Commands can only be executed via the input 0x06 (Write single register) in accordance with table 2.

Ad- dress	Words	Description	Value	Format
0xF001	1	Device reset	42	unsigned short
0xF002	1	Reset all maximum values	0	unsigned short
0xF003	1	Reset all minimum values	0	unsigned short
0xF004	1	Tariff switching to HT	Energy type 0-63	unsigned short
0xF005	1	Tariff switching to LT	Energy type 0-63	unsigned short
0xF006	1	Delete error status	0	unsigned short
0xF007	1	Delete daily energy meter (not supported)	0	unsigned short
0xF008	1	Switch relay - Example: 0x0201 switches on relay 2 - Relay must be set to bus mode with the device setting 0xD05A	MSB: 1: Relay 1 2: Relay 2 LSB: 0: Relay off 1: Relay on	unsigned short

Example Modbus RTU

Request: 01 06 F0 05 00 00 AA CB
in which

01	Device address
06	Command
F0 05	Register 0xF006 delete error status (in accordance with Modbus definition, the required address must be set to -1 in the request telex)
00 00	Value 0 (in accordance with definition in table 2)
AA CB	CRC code

Response: 01 06 F0 05 00 00 AA CB

in which

01	Device address
06	Command
F0 05	Register 0xF006 delete error status (in accordance with Modbus definition, the required address must be set to -1 in the request telex)
00 00	Value 0 (in accordance with definition in table 2)
AA CB	CRC code

Example Modbus ASCII

Request: 3A 30 31 31 30 44 30 30 31 30 30 30 34 30 38 30 30 30 30 31 39 30 30 30 30 30 31 39 30 30 30 30 30 31 39 30 46 30 0D 0A

in which

3A	Start telex (colon)
30 31	Device address 0x01
31 30	Command 0x10
44 30 30 31	Set registers 0xD002 to 0xD005 (in accordance with the Modbus definition, the required address must be set to -1 in the request telex)
30 30 30 34	Set 4 registers (primary voltage transformer 2 words and secondary 2 words)
30 38	Write number of bytes (8 bytes)
30 30 30 30 30 31 39 30	Primary voltage transformer 0x190 corresponds to dec. 400 V
30 30 30 30 30 31 39 30	Secondary voltage transformer 0x190 corresponds to dec. 400 V
46 30	LRC code
0D 0A	Telex end (CR LF)

Response: 3A 30 31 31 30 44 30 30 31 30 30 30 34 31 41 0D 0A

in which

3A	Start telex (colon)
30 31	Device address 0x01
31 30	Command 0x10
44 30 30 31	Registers 0xD002 to 0xD005 set
30 30 30 34	4 data bytes written
30 30 30 30	No limit violated with address 4 to 13
	Last 6 bits in byte 00 are without meaning
31 41	LRC code
0D 0A	Telex end (CR LF)

10.7 Limit violations

Limit violations are read via the command 0x02 (Read Discrete Inputs) in accordance with table 3

Address	Description of limit violations
0x0001	1st limit voltage PH-N L1
0x0002	1st limit voltage PH-N L2
0x0003	1st limit voltage PH-N L3
0x0004	2nd limit voltage PH-N L1
0x0005	2nd limit voltage PH-N L2
0x0006	2nd limit voltage PH-N L3
0x0007	1st limit voltage PH-PH L1
0x0008	1st limit voltage PH-PH L2
0x0009	1st limit voltage PH-PH L3
0x000a	2nd limit voltage PH-PH L1
0x000b	2nd limit voltage PH-PH L2
0x000c	2nd limit voltage PH-PH L3
0x000d	1st limit current L1
0x000e	1st limit current L2
0x000f	1st limit current L3
0x0010	2nd limit current L1
0x0011	2nd limit current L2
0x0012	2nd limit current L3
0x0013	1st limit current average value L1
0x0014	1st limit current average value L2
0x0015	1st limit current average value L3
0x0016	2nd limit current average value L1
0x0017	2nd limit current average value L2
0x0018	2nd limit current average value L3
0x0019	1st limit apparent power L1
0x001a	1st limit apparent power L2
0x001b	1st limit apparent power L3
0x001c	2nd limit apparent power L1

Address	Description of limit violations
0x001d	2nd limit apparent power L2
0x001e	2nd limit apparent power L3
0x001f	1st limit active power L1
0x0020	1st limit active power L2
0x0021	1st limit active power L3
0x0022	2nd limit active power L1
0x0023	2nd limit active power L2
0x0024	2nd limit active power L3
0x0025	1st limit reactive power L1
0x0026	1st limit reactive power L2
0x0027	1st limit reactive power L3
0x0028	2nd limit reactive power L1
0x0029	2nd limit reactive power L2
0x002a	2nd limit reactive power L3
0x002b	1st limit cos Phi L1
0x002c	1st limit cos Phi L2
0x002d	1st limit cos Phi L3
0x002e	2nd limit cos Phi L1
0x002f	2nd limit cos Phi L2
0x0030	2nd limit cos Phi L3
0x0031	1st limit power factor L1
0x0032	1st limit power factor L2
0x0033	1st limit power factor L3
0x0034	2nd limit power factor L1
0x0035	2nd limit power factor L2
0x0036	2nd limit power factor L3
0x0037	1st limit voltage THD (%) L1
0x0038	1st limit voltage THD (%) L2
0x0039	1st limit voltage THD (%) L3
0x003a	2nd limit voltage THD (%) L1
0x003b	2nd limit voltage THD (%) L2
0x003c	2nd limit voltage THD (%) L3

Address	Description of limit violations
0x003d	1st limit voltage 3rd harmonic L1
0x003e	1st limit voltage 3rd harmonic L2
0x003f	1st limit voltage 3rd harmonic L3
0x0040	2nd limit voltage 3rd harmonic L1
0x0041	2nd limit voltage 3rd harmonic L2
0x0042	2nd limit voltage 3rd harmonic L3
0x0043	1st limit voltage 5th harmonic L1
0x0044	1st limit voltage 5th harmonic L2
0x0045	1st limit voltage 5th harmonic L3
0x0046	2nd limit voltage 5th harmonic L1
0x0047	2nd limit voltage 5th harmonic L2
0x0048	2nd limit voltage 5th harmonic L3
0x0049	1st limit voltage 7th harmonic L1
0x004a	1st limit voltage 7th harmonic L2
0x004b	1st limit voltage 7th harmonic L3
0x004c	2nd limit voltage 7th harmonic L1
0x004d	2nd limit voltage 7th harmonic L2
0x004e	2nd limit voltage 7th harmonic L3
0x004f	1st limit voltage 9th harmonic L1
0x0050	1st limit voltage 9th harmonic L2
0x0051	1st limit voltage 9th harmonic L3
0x0052	2nd limit voltage 9th harmonic L1
0x0053	2nd limit voltage 9th harmonic L2
0x0054	2nd limit voltage 9th harmonic L3
0x0055	1st limit voltage 11th harmonic L1
0x0056	1st limit voltage 11th harmonic L2
0x0057	1st limit voltage 11th harmonic L3
0x0058	2nd limit voltage 11th harmonic L1
0x0059	2nd limit voltage 11th harmonic L2
0x005a	2nd limit voltage 11th harmonic L3
0x005b	1st limit voltage 13th harmonic L1
0x005c	1st limit voltage 13th harmonic L2

Address	Description of limit violations
0x005d	1st limit voltage 13th harmonic L3
0x005e	2nd limit voltage 13th harmonic L1
0x005f	2nd limit voltage 13th harmonic L2
0x0060	2nd limit voltage 13th harmonic L3
0x0061	1st limit total harmonic currents L1
0x0062	1st limit total harmonic currents L2
0x0063	1st limit total harmonic currents L3
0x0064	2nd limit total harmonic currents L1
0x0065	2nd limit total harmonic currents L2
0x0066	2nd limit total harmonic currents L3
0x0067	1st limit current 3rd harmonic L1
0x0068	1st limit current 3rd harmonic L2
0x0069	1st limit current 3rd harmonic L3
0x006a	2nd limit current 3rd harmonic L1
0x006b	2nd limit current 3rd harmonic L2
0x006c	2nd limit current 3rd harmonic L3
0x006d	1st limit current 5th harmonic L1
0x006e	1st limit current 5th harmonic L2
0x006f	1st limit current 5th harmonic L3
0x0070	2nd limit current 5th harmonic L1
0x0071	2nd limit current 5th harmonic L2
0x0072	2nd limit current 5th harmonic L3
0x0073	1st limit current 7th harmonic L1
0x0074	1st limit current 7th harmonic L2
0x0075	1st limit current 7th harmonic L3
0x0076	2nd limit current 7th harmonic L1
0x0077	2nd limit current 7th harmonic L2
0x0078	2nd limit current 7th harmonic L3
0x0079	1st limit current 9th harmonic L1
0x007a	1st limit current 9th harmonic L2
0x007b	1st limit current 9th harmonic L3
0x007c	2nd limit current 9th harmonic L1

Address	Description of limit violations
0x007d	2nd limit current 9th harmonic L2
0x007e	2nd limit current 9th harmonic L3
0x007f	1st limit current 11th harmonic L1
0x0080	1st limit current 11th harmonic L2
0x0081	1st limit current 11th harmonic L3
0x0082	2nd limit current 11th harmonic L1
0x0083	2nd limit current 11th harmonic L2
0x0084	2nd limit current 11th harmonic L3
0x0085	1st limit current 13th harmonic L1
0x0086	1st limit current 13th harmonic L2
0x0087	1st limit current 13th harmonic L3
0x0088	2nd limit current 13th harmonic L1
0x0089	2nd limit current 13th harmonic L2
0x008a	2nd limit current 13th harmonic L3
0x008b	1st limit network frequency
0x008c	2nd limit network frequency
0x008d	1st limit neutral conductor current
0x008e	2nd limit neutral conductor current
0x008f	1st limit average value neutral conductor current
0x0090	2nd limit average value neutral conductor current
0x0091	1st limit total active power
0x0092	2nd limit total active power
0x0093	1st limit total reactive power
0x0094	2nd limit total reactive power
0x0095	1st limit total apparent power
0x0096	2nd limit total apparent power
0x0097	1st limit power factor
0x0098	2nd limit power factor

Table 3

Example Modbus RTU

Request: 01 02 00 00 00 07 79 CC

in which

01	Device address
02	Command
00 00	Address 1st limit U-PhN L1 (in accordance with the Modbus definition, the required address must be set to -1 in the request telex)
00 07	Number of addresses to be evaluated (addresses 1 to 7)
79 CC	CRC code

Response: 01 02 01 07 E0 4A

in which

01	Device address
02	Command
01	Number of data bytes
07	1. limit U-PhN-L1 violated 1st limit U-PhN-L2 violated 1. limit U-PhN-L2 violated 2. limit U-PhN-L1 not violated 2. limit U-PhN-L2 not violated 2. limit U-PhN-L3 not violated 1st limit U-PhPh L1 not violated Last bit in byte is without meaning
E0 4A	CRC code

Example Modbus ASCII

Request: 3A 30 31 30 32 30 30 30 33 30 30 30 41 46 30 0D 0A
 in which

3A	Start telex (colon)
30 31	Device address 0x01
30 32	Command 0x02
30 30 30 33	Address 4th limit U-PhPh L1 (in accordance with the Modbus definition, the required address must be set to -1 in the request telex)
30 30 30 41	Number of addresses to be evaluated 0x0A
46 30	LRC code
0D 0A	Telex end (CR LF)

Response: 3A 30 31 30 32 30 32 30 30 30 30 46 42 0D 0A
 in which

3A	Start telex (colon)
30 31	Device address 0x01
30 32	Command
30 32	Number of data bytes 0x02
30 30 30 30	No limit violated with address 4 to 13
	Last 6 bits in byte 00 are without meaning
46 42	LRC code
0D 0A	Telex end (CR LF)

10.8 Data points

Data points are read via the command 0x04 (Read Input Registers) in accordance with table 4

Address	Words	Description	Unit	Format
0x0002	2	Voltage PH-N L1	V	float
0x0004	2	Voltage PH-N L2	V	float
0x0006	2	Voltage PH-N L3	V	float
0x0008	2	Voltage PH-PH L1	V	float
0x000a	2	Voltage PH-PH L2	V	float
0x000c	2	Voltage PH-PH L3	V	float
0x000e	2	Current L1	A	float
0x0010	2	Current L2	A	float
0x0012	2	Current L3	A	float
0x0014	2	Current average value L1	A	float
0x0016	2	Current average value L2	A	float
0x0018	2	Current average value L3	A	float
0x001a	2	Apparent power L1	VA	float
0x001c	2	Apparent power L2	VA	float
0x001e	2	Apparent power L3	VA	float
0x0020	2	Active power L1	W	float
0x0022	2	Active power L2	W	float
0x0024	2	Active power L3	W	float
0x0026	2	Reactive power L1	var	float
0x0028	2	Reactive power L2	var	float
0x002a	2	Reactive power L3	var	float
0x002c	2	cos Phi L1		float
0x002e	2	cos Phi L2		float
0x0030	2	cos Phi L3		float
0x0032	2	Power factor L1		float
0x0034	2	Power factor L2		float
0x0036	2	Power factor L3		float
0x0038	2	Voltage THD (%f) L1	%	float

Address	Words	Description	Unit	Format
0x003a	2	Voltage THD (%f) L2	%	float
0x003c	2	Voltage THD (%f) L3	%	float
0x003e	2	Voltage 3rd harmonic L1	%	float
0x0040	2	Voltage 3rd harmonic L2	%	float
0x0042	2	Voltage 3rd harmonic L3	%	float
0x0044	2	Voltage 5th harmonic L1	%	float
0x0046	2	Voltage 5th harmonic L2	%	float
0x0048	2	Voltage 5th harmonic L3	%	float
0x004a	2	Voltage 7th harmonic L1	%	float
0x004c	2	Voltage 7th harmonic L2	%	float
0x004e	2	Voltage 7th harmonic L3	%	float
0x0050	2	Voltage 9th harmonic L1	%	float
0x0052	2	Voltage 9th harmonic L2	%	float
0x0054	2	Voltage 9th harmonic L3	%	float
0x0056	2	Voltage 11th harmonic L1	%	float
0x0058	2	Voltage 11th harmonic L2	%	float
0x005a	2	Voltage 11th harmonic L3	%	float
0x005c	2	Voltage 13th harmonic L1	%	float
0x005e	2	Voltage 13th harmonic L2	%	float
0x0060	2	Voltage 13th harmonic L3	%	float
0x0062	2	Voltage 15th harmonic L1	%	float
0x0064	2	Voltage 15th harmonic L2	%	float
0x0066	2	Voltage 15th harmonic L3	%	float
0x0068	2	Voltage 17th harmonic L1	%	float
0x006a	2	Voltage 17th harmonic L2	%	float
0x006c	2	Voltage 17th harmonic L3	%	float
0x006e	2	Voltage 19th harmonic L1	%	float
0x0070	2	Voltage 19th harmonic L2	%	float
0x0072	2	Voltage 19th harmonic L3	%	float
0x0074	2	Total harmonic currents L1	A	float
0x0076	2	Total harmonic currents L2	A	float
0x0078	2	Total harmonic currents L3	A	float

Address	Words	Description	Unit	Format
0x007a	2	Current 3rd harmonic L1	A	float
0x007c	2	Current 3rd harmonic L2	A	float
0x007e	2	Current 3rd harmonic L3	A	float
0x0080	2	Current 5th harmonic L1	A	float
0x0082	2	Current 5th harmonic L2	A	float
0x0084	2	Current 5th harmonic L3	A	float
0x0086	2	Current 7th harmonic L1	A	float
0x0088	2	Current 7th harmonic L2	A	float
0x008a	2	Current 7th harmonic L3	A	float
0x008c	2	Current 9th harmonic L1	A	float
0x008e	2	Current 9th harmonic L2	A	float
0x0090	2	Current 9th harmonic L3	A	float
0x0092	2	Current 11th harmonic L1	A	float
0x0094	2	Current 11th harmonic L2	A	float
0x0096	2	Current 11th harmonic L3	A	float
0x0098	2	Current 13th harmonic L1	A	float
0x009a	2	Current 13th harmonic L2	A	float
0x009c	2	Current 13th harmonic L3	A	float
0x009e	2	Current 15th harmonic L1	A	float
0x00a0	2	Current 15th harmonic L2	A	float
0x00a2	2	Current 15th harmonic L3	A	float
0x00a4	2	Current 17th harmonic L1	A	float
0x00a6	2	Current 17th harmonic L2	A	float
0x00a8	2	Current 17th harmonic L3	A	float
0x00aa	2	Current 19th harmonic L1	A	float
0x00ac	2	Current 19th harmonic L2	A	float
0x00ae	2	Current 19th harmonic L3	A	float
0x00b0	2	Network frequency	Hz	float
0x00b2	2	Neutral conductor current	A	float
0x00b4	2	Average value neutral conductor current	A	float
0x00b6	2	Total active power	W	float
0x00b8	2	Total reactive power	var	float

Address	Words	Description	Unit	Format
0x00ba	2	Total apparent power	VA	float
0x00bc	2	Power factor		float
0x00be	2	Condition relay 1		unsigned long
0x00c0	2	Condition relay 2		unsigned long
0x00c2	2	Error state		unsigned long
0x00c4	2	Time		unsigned long
0x00c6	2	Maximum: Voltage PH-N L1	V	float
0x00c8	2	Maximum: Voltage PH-N L2	V	float
0x00ca	2	Maximum: Voltage PH-N L3	V	float
0x00cc	2	Maximum: voltage PH-PH L1	V	float
0x00ce	2	Maximum: Voltage PH-PH L2	V	float
0x00d0	2	Maximum: Voltage PH-PH L3	V	float
0x00d2	2	Maximum: Current L1	A	Float
0x00d4	2	Maximum: Current L2	A	float
0x00d6	2	Maximum: Current L3	A	float
0x00d8	2	Maximum: Current average value L1	A	float
0x00da	2	Maximum: Current average value L2	A	float
0x00dc	2	Maximum: Current average value L3	A	float
0x00de	2	Maximum: Apparent power L1	VA	float
0x00e0	2	Maximum: Apparent power L2	VA	float
0x00e2	2	Maximum: Apparent power L3	VA	float
0x00e4	2	Maximum: Active power L1	W	float
0x00e6	2	Maximum: Active power L2	W	float
0x00e8	2	Maximum: Active power L3	W	float
0x00ea	2	Maximum: Reactive power L1	var	float
0x00ec	2	Maximum: Reactive power L2	var	float
0x00ee	2	Maximum: Reactive power L3	var	float
0x00f0	2	Maximum: cos Phi L1		float
0x00f2	2	Maximum: cos Phi L2		float
0x00f4	2	Maximum: cos Phi L3		float
0x00f6	2	Maximum: Power factor L1		float
0x00f8	2	Maximum: Power factor L2		float

Address	Words	Description	Unit	Format
0x00fa	2	Maximum: Power factor L3		float
0x00fc	2	Maximum: Voltage THD (%) L1	%	float
0x00fe	2	Maximum: Voltage THD (%) L2	%	float
0x0100	2	Maximum: Voltage THD (%) L3	%	float
0x0102	2	Maximum: Voltage 3rd harmonic L1	%	float
0x0104	2	Maximum: Voltage 3rd harmonic L2	%	float
0x0106	2	Maximum: Voltage 3rd harmonic L3	%	float
0x0108	2	Maximum: Voltage 5th harmonic L1	%	float
0x010a	2	Maximum: Voltage 5th harmonic L2	%	float
0x010c	2	Maximum: Voltage 5th harmonic L3	%	float
0x010e	2	Maximum: Voltage 7th harmonic L1	%	float
0x0110	2	Maximum: Voltage 7th harmonic L2	%	float
0x0112	2	Maximum: Voltage 7th harmonic L3	%	float
0x0114	2	Maximum: Voltage 9th harmonic L1	%	float
0x0116	2	Maximum: Voltage 9th harmonic L2	%	float
0x0118	2	Maximum: Voltage 9th harmonic L3	%	float
0x011a	2	Maximum: Voltage 11th harmonic L1	%	float
0x011c	2	Maximum: Voltage 11th harmonic L2	%	float
0x011e	2	Maximum: Voltage 11th harmonic L3	%	float
0x0120	2	Maximum: Voltage 13th harmonic L1	%	float
0x0122	2	Maximum: Voltage 13th harmonic L2	%	float
0x0124	2	Maximum: Voltage 13th harmonic L3	%	float
0x0126	2	Maximum: Voltage 15th harmonic L1	%	float
0x0128	2	Maximum: Voltage 15th harmonic L2	%	float
0x012a	2	Maximum: Voltage 15th harmonic L3	%	float
0x012c	2	Maximum: Voltage 17th harmonic L1	%	float
0x012e	2	Maximum: Voltage 17th harmonic L2	%	float
0x0130	2	Maximum: Voltage 17th harmonic L3	%	float
0x0132	2	Maximum: Voltage 19th harmonic L1	%	float
0x0134	2	Maximum: Voltage 19th harmonic L2	%	float
0x0136	2	Maximum: Voltage 19th harmonic L3	%	float
0x0138	2	Maximum: Total harmonic currents L1	A	float

Address	Words	Description	Unit	Format
0x013a	2	Maximum: Total harmonic currents L2	A	float
0x013c	2	Maximum: Total harmonic currents L3	A	float
0x013e	2	Maximum: Current 3rd harmonic L1	A	float
0x0140	2	Maximum: Current 3rd harmonic L2	A	float
0x0142	2	Maximum: Current 3rd harmonic L3	A	float
0x0144	2	Maximum: Current 5th harmonic L1	A	float
0x0146	2	Maximum: Current 5th harmonic L2	A	float
0x0148	2	Maximum: Current 5th harmonic L3	A	float
0x014a	2	Maximum: Current 7th harmonic L1	A	float
0x014c	2	Maximum: Current 7th harmonic L2	A	float
0x014e	2	Maximum: Current 7th harmonic L3	A	float
0x0150	2	Maximum: Current 9th harmonic L1	A	float
0x0152	2	Maximum: Current 9th harmonic L2	A	float
0x0154	2	Maximum: Current 9th harmonic L3	A	float
0x0156	2	Maximum: Current 11th harmonic L1	A	float
0x0158	2	Maximum: Current 11th harmonic L2	A	float
0x015a	2	Maximum: Current 11th harmonic L3	A	float
0x015c	2	Maximum: Current 13th harmonic L1	A	float
0x015e	2	Maximum: Current 13th harmonic L2	A	float
0x0160	2	Maximum: Current 13th harmonic L3	A	float
0x0162	2	Maximum: Current 15th harmonic L1	A	float
0x0164	2	Maximum: Current 15th harmonic L2	A	float
0x0166	2	Maximum: Current 15th harmonic L3	A	float
0x0168	2	Maximum: Current 17th harmonic L1	A	float
0x016a	2	Maximum: Current 17th harmonic L2	A	float
0x016c	2	Maximum: Current 17th harmonic L3	A	float
0x016e	2	Maximum: Current 19th harmonic L1	A	float
0x0170	2	Maximum: Current 19th harmonic L2	A	float
0x0172	2	Maximum: Current 19th harmonic L3	A	float
0x0174	2	Maximum: Network frequency	Hz	float
0x0176	2	Maximum: Neutral conductor current	A	float
0x0178	2	Maximum: Average value neutral conductor current	A	float

Address	Words	Description	Unit	Format
0x017a	2	Maximum: Total active power	W	float
0x017c	2	Maximum: Total reactive power	var	float
0x017e	2	Maximum: Total apparent power	VA	float
0x0180	2	Maximum: Power factor		float
0x0182	2	Minimum: Voltage PH-N L1	V	float
0x0184	2	Minimum: Voltage PH-N L2	V	float
0x0186	2	Minimum: Voltage PH-N L3	V	float
0x0188	2	Minimum: voltage PH-PH L1	V	float
0x018a	2	Minimum: Voltage PH-PH L2	V	float
0x018c	2	Minimum: Voltage PH-PH L3	V	float
0x018e	2	Minimum: Current L1	A	float
0x0190	2	Minimum: Current L2	A	float
0x0192	2	Minimum: Current L3	A	float
0x0194	2	Minimum: Current average value L1	A	float
0x0196	2	Minimum: Current average value L2	A	float
0x0198	2	Minimum: Current average value L3	A	float
0x019a	2	Minimum: Apparent power L1	VA	float
0x019c	2	Minimum: Apparent power L2	VA	float
0x019e	2	Minimum: Apparent power L3	VA	float
0x01a0	2	Minimum: Active power L1	W	float
0x01a2	2	Minimum: Active power L2	W	float
0x01a4	2	Minimum: Active power L3	W	float
0x01a6	2	Minimum: Reactive power L1	var	float
0x01a8	2	Minimum: Reactive power L2	var	float
0x01aa	2	Minimum: Reactive power L3	var	float
0x01ac	2	Minimum: cos Phi L1		float
0x01ae	2	Minimum: cos Phi L2		float
0x01b0	2	Minimum: cos Phi L3		float
0x01b2	2	Minimum: Power factor L1		float
0x01b4	2	Minimum: Power factor L2		float
0x01b6	2	Minimum: Power factor L3		float
0x01b8	2	Minimum: Network frequency	Hz	float

Address	Words	Description	Unit	Format
0x01ba	2	Minimum: Neutral conductor current	A	float
0x01bc	2	Min.: Average value neutral conductor current	A	float
0x01be	2	Minimum: Total active power	W	float
0x01c0	2	Minimum: Total reactive power	var	float
0x01c2	2	Minimum: Total apparent power	VA	float
0x01c4	2	Minimum: Power factor		float
0x01c6	2	Max date: Voltage PH-N L1		unsigned long
0x01c8	2	Max date: Voltage PH-N L2		unsigned long
0x01ca	2	Max date: Voltage PH-N L3		unsigned long
0x01cc	2	Max date: Voltage PH-PH L1		unsigned long
0x01ce	2	Max date: Voltage PH-PH L2		unsigned long
0x01d0	2	Max date: Voltage PH-PH L3		unsigned long
0x01d2	2	Max date: Current L1		unsigned long
0x01d4	2	Maximum date: Current L2		unsigned long
0x01d6	2	Maximum date: Current L3		unsigned long
0x01d8	2	Max date: Current average value L1		unsigned long
0x01da	2	Max date: Current average value L2		unsigned long
0x01dc	2	Max date: Current average value L3		unsigned long
0x01de	2	Max date: Apparent power L1		unsigned long
0x01e0	2	Max date: Apparent power L2		unsigned long
0x01e2	2	Max date: Apparent power L3		unsigned long
0x01e4	2	Maximum date: Active power L1		unsigned long
0x01e6	2	Maximum date: Active power L2		unsigned long
0x01e8	2	Maximum date: Active power L3		unsigned long
0x01ea	2	Maximum date: Reactive power L1		unsigned long
0x01ec	2	Maximum date: Reactive power L2		unsigned long
0x01ee	2	Maximum date: Reactive power L3		unsigned long
0x01f0	2	Maximum date: cos Phi L1		unsigned long
0x01f2	2	Maximum date: cos Phi L2		unsigned long
0x01f4	2	Maximum date: cos Phi L3		unsigned long
0x01f6	2	Maximum date: Power factor L1		unsigned long
0x01f8	2	Maximum date: Power factor L2		unsigned long

Address	Words	Description	Unit	Format
0x01fa	2	Max date: Power factor L3		unsigned long
0x01fc	2	Max date: Voltage THD (%f) L1		unsigned long
0x01fe	2	Max date: Voltage THD (%f) L2		unsigned long
0x0200	2	Max date: Voltage THD (%f) L3		unsigned long
0x0202	2	Max date: Voltage 3rd harmonic L1		unsigned long
0x0204	2	Max date: Voltage 3rd harmonic L2		unsigned long
0x0206	2	Max date: Voltage 3rd harmonic L3		unsigned long
0x0208	2	Max date: Voltage 5th harmonic L1		unsigned long
0x020a	2	Max date: Voltage 5th harmonic L2		unsigned long
0x020c	2	Max date: Voltage 5th harmonic L3		unsigned long
0x020e	2	Max date: Voltage 7th harmonic L1		unsigned long
0x0210	2	Max date: Voltage 7th harmonic L2		unsigned long
0x0212	2	Max date: Voltage 7th harmonic L3		unsigned long
0x0214	2	Max date: Voltage 9th harmonic L1		unsigned long
0x0216	2	Max date: Voltage 9th harmonic L2		unsigned long
0x0218	2	Max date: Voltage 9th harmonic L3		unsigned long
0x021a	2	Max date: Voltage 11th harmonic L1		unsigned long
0x021c	2	Max date: Voltage 11th harmonic L2		unsigned long
0x021e	2	Max date: Voltage 11th harmonic L3		unsigned long
0x0220	2	Max date: Voltage 13th harmonic L1		unsigned long
0x0222	2	Max date: Voltage 13th harmonic L2		unsigned long
0x0224	2	Max date: Voltage 13th harmonic L3		unsigned long
0x0226	2	Max date: Voltage 15th harmonic L1		unsigned long
0x0228	2	Max date: Voltage 15th harmonic L2		unsigned long
0x022a	2	Max date: Voltage 15th harmonic L3		unsigned long
0x022c	2	Max date: Voltage 17th harmonic L1		unsigned long
0x022e	2	Max date: Voltage 17th harmonic L2		unsigned long
0x0230	2	Max date: Voltage 17th harmonic L3		unsigned long
0x0232	2	Max date: Voltage 19th harmonic L1		unsigned long
0x0234	2	Max date: Voltage 19th harmonic L2		unsigned long
0x0236	2	Max date: Voltage 19th harmonic L3		unsigned long

Address	Words	Description	Unit	Format
0x0238	2	Maximum date: Total harmonic currents L1		unsigned long
0x023a	2	Maximum date: Total harmonic currents L2		unsigned long
0x023c	2	Maximum date: Total harmonic currents L3		unsigned long
0x023e	2	Maximum date: Current 3rd harmonic L1		unsigned long
0x0240	2	Maximum date: Current 3rd harmonic L2		unsigned long
0x0242	2	Maximum date: Current 3rd harmonic L3		unsigned long
0x0244	2	Maximum date: Current 5th harmonic L1		unsigned long
0x0246	2	Maximum date: Current 5th harmonic L2		unsigned long
0x0248	2	Maximum date: Current 5th harmonic L3		unsigned long
0x024a	2	Maximum date: Current 7th harmonic L1		unsigned long
0x024c	2	Maximum date: Current 7th harmonic L2		unsigned long
0x024e	2	Maximum date: Current 7th harmonic L3		unsigned long
0x0250	2	Maximum date: Current 9th harmonic L1		unsigned long
0x0252	2	Maximum date: Current 9th harmonic L2		unsigned long
0x0254	2	Maximum date: Current 9th harmonic L3		unsigned long
0x0256	2	Maximum date: Current 11th harmonic L1		unsigned long
0x0258	2	Maximum date: Current 11th harmonic L2		unsigned long
0x025a	2	Maximum date: Current 11th harmonic L3		unsigned long
0x025c	2	Maximum date: Current 13th harmonic L1		unsigned long
0x025e	2	Maximum date: Current 13th harmonic L2		unsigned long
0x0260	2	Maximum date: Current 13th harmonic L3		unsigned long
0x0262	2	Maximum date: Current 15th harmonic L1		unsigned long
0x0264	2	Maximum date: Current 15th harmonic L2		unsigned long
0x0266	2	Maximum date: Current 15th harmonic L3		unsigned long
0x0268	2	Maximum date: Current 17th harmonic L1		unsigned long
0x026a	2	Maximum date: Current 17th harmonic L2		unsigned long
0x026c	2	Maximum date: Current 17th harmonic L3		unsigned long
0x026e	2	Maximum date: Current 19th harmonic L1		unsigned long
0x0270	2	Maximum date: Current 19th harmonic L2		unsigned long

Address	Words	Description	Unit	Format
0x0272	2	Maximum date: Current 19th harmonic L3		unsigned long
0x0274	2	Maximum date: Network frequency		unsigned long
0x0276	2	Maximum date: Neutral conductor current		unsigned long
0x0278	2	Max date: Average value neutral conductor current		unsigned long
0x027a	2	Max date: Total active power		unsigned long
0x027c	2	Max date: Total reactive power		unsigned long
0x027e	2	Max date: Total apparent power		unsigned long
0x0280	2	Maximum date: Power factor		unsigned long
0x0282	2	Minimum date: Voltage PH-N L1		unsigned long
0x0284	2	Minimum date: Voltage PH-N L2		unsigned long
0x0286	2	Minimum date: Voltage PH-N L3		unsigned long
0x0288	2	Minimum date: Voltage PH-PH L1		unsigned long
0x028a	2	Minimum date: Voltage PH-PH L2		unsigned long
0x028c	2	Minimum date: Voltage PH-PH L3		unsigned long
0x028e	2	Minimum date: Current L1		unsigned long
0x0290	2	Minimum date: Current L2		unsigned long
0x0292	2	Minimum date: Current L3		unsigned long
0x0294	2	Minimum date: Current average value L1		unsigned long
0x0296	2	Minimum date: Current average value L2		unsigned long
0x0298	2	Minimum date: Current average value L3		unsigned long
0x029a	2	Minimum date: Apparent power L1		unsigned long
0x029c	2	Minimum date: Apparent power L2		unsigned long
0x029e	2	Minimum date: Apparent power L3		unsigned long
0x02a0	2	Minimum date: Active power L1		unsigned long
0x02a2	2	Minimum date: Active power L2		unsigned long
0x02a4	2	Minimum date: Active power L3		unsigned long
0x02a6	2	Minimum date: Reactive power L1		unsigned long
0x02a8	2	Minimum date: Reactive power L2		unsigned long
0x02aa	2	Minimum date: Reactive power L3		unsigned long
0x02ac	2	Maximum date: cos Phi L1		unsigned long
0x02ae	2	Maximum date: cos Phi L2		unsigned long
0x02b0	2	Maximum date: cos Phi L3		unsigned long
0x02b2	2	Minimum date: Power factor L1		unsigned long
0x02b4	2	Minimum date: Power factor L2		unsigned long
0x02b6	2	Minimum date: Power factor L3		unsigned long
0x02b8	2	Minimum date: Network frequency		unsigned long

Address	Words	Description	Unit	Format
0x02ba	2	Minimum date: Neutral conductor current		unsigned long
0x02bc	2	Minimum date: Average value neutral conductor current		unsigned long
0x02be	2	Minimum date: Total active power		unsigned long
0x02c0	2	Minimum date: Total reactive power		unsigned long
0x02c2	2	Minimum date: Total apparent power		unsigned long
0x02c4	2	Minimum date: Power factor		unsigned long
0x02c6	2	Active power meter reading (HT/consumption)	Wh	float
0x02c8	2	Active energy meter reading (LT/consumption)	Wh	float
0x02ca	2	Reactive energy meter reading (HT/consumption)	varh	float
0x02cc	2	Reactive energy meter reading (LT/consumption)	varh	float
0x02ce	2	Today: active energy HT/consumption	Wh	float
0x02d0	2	Today: active energy LT/consumption	Wh	float
0x02d2	2	Today: reactive energy HT/consumption	varh	float
0x02d4	2	Today: reactive energy LT/consumption	varh	float
0x02d6	2	Previous day: active energy HT/consumption	Wh	float
0x02d8	2	Previous day: active energy LT/consumption	Wh	float
0x02da	2	Previous day: reactive energy HT/consumption	varh	float
0x02dc	2	Previous day: reactive energy LT/consumption	varh	float
0x02de	2	Current month: active energy HT/consumption	Wh	float
0x02e0	2	Current month: active energy LT/consumption	Wh	float
0x02e2	2	Current month: reactive energy HT/consumption	varh	float
0x02e4	2	Current month: reactive energy LT/consumption	varh	float
0x02e6	2	Last month: active energy HT/consumption	Wh	float
0x02e8	2	Last month: reactive energy LT/consumption	Wh	float

Address	Words	Description	Unit	Format
0x02ea	2	Last month: reactive energy HT/consumption	varh	float
0x02ec	2	Last month: reactive energy LT/consumption	varh	float
0x02ee	2	Tariff index		unsigned long
0x02f0	2	Active energy meter reading (HT/recovery)	Wh	float
0x02f2	2	Active energy meter reading (LT/recovery)	Wh	float
0x02f4	2	Reactive energy meter reading (HT/recovery)	varh	float
0x02f6	2	Reactive energy meter reading (LT/recovery)	varh	float
0x02f8	2	Today: active energy HT recovery	Wh	float
0x02fa	2	Today: active energy LT recovery	Wh	float
0x02fc	2	Today: reactive energy HT recovery	varh	float
0x02fe	2	Today: reactive energy LT recovery	varh	float
0x0300	2	Previous day: active energy HT recovery	Wh	float
0x0302	2	Previous day: active energy LT recovery	Wh	float
0x0304	2	Previous day: reactive energy HT recovery	varh	float
0x0306	2	Previous day: reactive energy LT recovery	varh	float
0x0308	2	Current month: active energy HT recovery	Wh	float
0x030a	2	Current month: active energy LT recovery	Wh	float
0x030c	2	Current month: reactive energy HT recovery	varh	float
0x030e	2	Current month: reactive energy LT recovery	varh	float
0x0310	2	Last month: active energy HT recovery	Wh	float
0x0312	2	Last month: active energy LT recovery	Wh	float
0x0314	2	Last month: reactive energy HT recovery	varh	float
0x0316	2	Last month: reactive energy LT recovery	varh	float
0x0318	2	Status of digital inputs Bit 0: IN0 (sync input) (1 = active) Bit 1: IN1 (tariff input) (1 = active) (not supported)	-	unsigned long
0x031a	2	Phase angle U L12	Degree	float
0x031c	2	Phase angle U L23	Degree	float
0x031e	2	Phase angle U L31	Degree	float
0x0320	2	Voltage asymmetry (not supported)	%	float

Address	Words	Description	Unit	Format
0x1002	2	Last saved period value active power consumption	W	float
0x1004	2	Last saved period value reactive power consumption	var	float
0x1006	2	Last saved period value active power recovery	W	float
0x1008	2	Last saved period value reactive power recovery	var	float
0x100A	2	Timestamp of the period values last saved	s	unsigned long
0x100C	2	Instantaneous value of the current period active power consumption	W	float
0x100E	2	Instantaneous value of the current period reactive power consumption	var	float
0x1010	2	Instantaneous value of the current period active power recovery	W	float
0x1012	2	Instantaneous value of the current period reactive power recovery	var	float
0x1014	2	Remaining period time	s	unsigned long
0x1016	2	Period duration	min	unsigned long
0xE002	4	Active power meter reading (HT/consumption)	Wh	double
0xE006	4	Active energy meter reading (LT/consumption)	Wh	double
0xE00A	4	Reactive energy meter reading (HT/consumption)	varh	double
0xE00E	4	Reactive energy meter reading (LT/consumption)	varh	double
0xE012	4	Active energy meter reading (HT/recovery)	Wh	double
0xE016	4	Active energy meter reading (LT/recovery)	Wh	double
0xE01A	4	Reactive energy meter reading (HT/recovery)	varh	double
0xE01E	4	Reactive energy meter reading (LT/recovery)	varh	double

Table 4

Example Modbus ASCII

Request: 3A 30 31 30 34 30 31 31 31 30 30 30 32 45 37 0D 0A
in which

3A	Start telex (colon)
30 31	Device address 0x01
30 34	Command 0x40
30 31 31 31	Read from register 0x0112 (in accordance with the Modbus definition, the required address must be set to -1 in the request telex)
30 30 30 32	Read 2 registers, i.e. read 1 measured value (maximum: Voltage 7th harmonic L3)
45 37	LRC code
0D 0A	Telex end (CR LF)

Response: 3A 30 31 30 34 30 34 34 30 30 38 42 34 41 35 35 36 0D 0A
in which

3A	Start telex (colon)
30 31	Device address 0x01
30 34	Command 0x40
30 34	4 data bytes
34 30 30 38 42 34 41 35	Maximum: Voltage 7th harmonic L3 2.14%
35 46	LRC code
0D 0A	Telex end (CR LF)

Example Modbus RTU

Request: 01 04 00 1F 00 32 40 19
in which

01	Device address
04	Command
00 1F	Read active power L1 from register 0x0020 (in accordance with the Modbus definition, the required address must be set to -1 in the request telex)
00 32	Read 50 registers, i.e. read 25 data points
40 19	CRC code

Response: 01 04 64 40 DC E6 64 40 E0 04 82 40 DE 3A B9 BF D3 93 AA BF EC A4 F6 BF E1 4E A1 BF 75 D5 91 BF 73 31 3C BF 74 6B 27 3E E5 63 6C 3E E5 63 6C 3E E5 63 6C 3F A8 F5 B7 3F 95 42 3D 3F A9 37 D3 3D 47 37 08 3A 5B 37 38 3D 18 1C 8C 3F 9E CB 1C 3F 8A 47 2F 3F 9F 01 93 3E A6 01 35 3E 9F 01 97 3E A7 86 3D 3E 9E CB 1C FE B3

in which

01	Device address	
04	Command	
64	100 data bytes	
40 DC E6 64	Active power L1	6.90 W
40 E0 04 82	Active power L2	7.00 W
40 DE 3A B9	Active power L3	6.94 W
BF D3 93 AA	Reactive power L1	-1.65 var
BF EC A4 F6	Reactive power L2	-1.85 var
BF E1 4E A1	Reactive power L3	-1.76 var
BF 75 D5 91	cos Phi L1	-0.96
BF 73 31 3C	cos Phi L2	-0.95
BF 74 6B 27	cos Phi L3	-0.95
3E E5 63 6C	Power factor L1	12:45 AM
3E E5 63 6C	Power factor L2	12:45 AM
3E E5 63 6C	Power factor L3	12:45 AM
3F A8 F5 B7	Voltage THD (%) L1	1.32 %
3F 95 42 3D	Voltage THD (%) L2	1.17 %
3F A9 37 D3	Voltage THD (%) L3	1.32 %
3D 47 37 08	Voltage 3rd harmonic L1	0.05 %
3A 5B 37 38	Voltage 3rd harmonic L2	0.00 %
3D 18 1C 8C	Voltage 3rd harmonic L3	0.04 %
3F 9E CB 1C	Voltage 5th harmonic L1	1.24 %
3F 8A 47 2F	Voltage 5th harmonic L2	1.08 %
3F 9F 01 93	Voltage 5th harmonic L3	1.24 %
3E A6 01 35	Voltage 7th harmonic L1	0.32 %
3F 9F 01 97	Voltage 7th harmonic L2	0.31 %
3E A7 86 3D	Voltage 7th harmonic L3	0.33 %
3F 9E CB 1C	Voltage 9th harmonic L1	0.31 %
FE B3	CRC code	

10.9 Device information

The device information is read via the command 0x2B (Read Device Identification)

Information about the manufacturer, device code and device version is read in the process. The device supplies the "Basic Device Identification". "Regular" and "Extended Device Identification" are optional according to the Modbus definition. They are not used in the Multimes Comfort.

Example Modbus RTU

Request: 01 2B 0E 01 00 70 77
in which

01	Device address
2B	Command
0E	MEI type according to the Modbus definition always 0x0E
01	Device ID code for "Basic Device Identification" (see Modbus definition)
00	Object ID -> in our example manufacturer name, product name and version
70 77	CRC code

Response: 01 2B 0E 01 01 00 00 03 00 08 4B 42 52 20 47 6D 62 48 01 11 4D 75 6C 74 69 6D 65 73 73 20 43 6F 6D 66 6F 72 74 02 09 20 31 2E 30 32 72 30 30 36 0C A8 in which

01	Device address
2B	Command
0E	MEI type (see Modbus definition)
01	"Basic identification" (see Modbus definition)
01	"Conformity level" (see Modbus definition)
00	No further information follows (no additional telex required)
00	Next object ID
03	Number of objects
00	Object ID 00
08	Text length of ID 00
4B 42 52 20 47 6D 62 48	"KBR GmbH"
01	Object ID 01
11	Text length of ID 01
4D 75 6C 74 69 6D 65 73 73 20 43 6F 6D 66 6F 72 74	"Multimes Comfort"
02	Object ID 02
09	Text length of ID 02
20 31 2E 30 32 72 30 30 36	" 1.02r006"
0C A8	CRC code

Example Modbus ASCII

3A 30 31 32 42 30 45 30 31 30 32 43 33 0D 0A
 in which

3A	Start telex (colon)
30 31	Device address 0x01
32 42	Command 0x2B
30 45	MEI type according to the Modbus definition always 0x0E
30 31	Device ID code for "Basic Device Identification" (see Modbus definition)
30 32	Object ID -> in our example 02 read Version and Release
43 33	LRC code
0D 0A	Telex end (CR LF)

Response: 3A 30 31 32 42 30 45 30 31 30 31 30 30 30 32 30 31 30 32 30 39 32 30 33 31 32
 45 33 30 33 32 37 32 33 30 33 30 33 36 43 44 0D 0A
 in which

3A	Start telex (colon)
30 31	Device address 0x01
32 42	Command
30 45	MEI type (see Modbus definition)
30 31	"Basic identification" (see Modbus definition)
30 31	"Conformity level" (see Modbus definition)
30 30	No further information follows (no additional telex required)
30 32	Next object ID
30 31	Number of objects
30 32	Object ID 02
30 39	Text length of ID 02
32 30 33 31 32 45 33 30 33 32 37 32 33 30 33 30 33 36	"1.02r006"
43 44	LRC code
0D 0A	Telex end (CR LF)

KBR Kompensationsanlagenbau GmbH

Am Kieferschlag 7
D-91126 Schwabach
Germany

T +49 (0) 9122 6373-0
F +49 (0) 9122 6373-83
E info@kbr.de

www.kbr.de