



## User manual Technical parameters

**multimes**

### Three-phase network measuring device

**F144-0-LED-EP-...-5**

**F144-1-LED-ESMS...-5**

**F144-1-LED-ESMSDP...-5**



**Your partner for  
network analysis**

1	Device memory, battery-buffered .....8	8.4	S - Apparent power / total apparent power ..... 30
2	Definition of terms..... 10	8.5	P - Active power / total active power ..... 31
3	Field of application / range of functions..... 11	8.6	Q - Reactive power / total reactive power ..... 32
4	Connecting the multimes F144-0-LED-EP...-5 / F144-1-LED-ESMS...-5 ..... 13	8.7	Cos $\varphi$ - Fundamental power factor, PF, total PF ..... 33
4.1	Installation and assembly ..... 13	7.8	kWh - Active energy HT/LT consumption, maximum cumu- lated cycle active power ..... 34
4.2	Installation ..... 13	8.9	kvarh - Reactive energy counter HT/LT consumption, maximum cumulated cycle reactive power..... 36
4.3	Connection diagram ..... 17	8.10	Harmon. - distortion factor and partial oscillation of the network harmonics for voltage and current..... 38
4.4	Terminal assignment..... 18	8.11	Extra ..... 39
5	Control and display panel ..... 20	8.12	Maximum / Minimum extreme values display ..... 42
5.1	Description of sensor buttons and displays..... 21	8.13	Displaying limits ..... 45
6	Operation ..... 22	9	Programming..... 47
6.1	Menu structure of the multimes F144-0-EP...-5 / F144-1-LED-ESMS...-5 ..... 22	9.1	Period time current average value ..... 47
6.2	Navigation and device displays.. 23	9.2	Tariff switching method..... 48
7	Setting operating parameters..... 24	9.3	Measurement period synchronization ..... 49
7.1	General programming scheme... 24	9.4	Programming limits..... 50
7.2	U Ph-Ph - Measuring reference voltage / rated mains voltage..... 25	9.5	Setting time and date..... 52
7.3	I - Current transformer ratio ..... 26	9.6	Setting the bus address ..... 53
8	Display functions..... 27	9.7	Setting the bus protocol..... 54
8.1	UPh-N - Voltage phase to neutral conductor, frequency..... 27	9.8	Setting the Modbus bus address and baud rate ..... 55
8.2	UPh-Ph - Voltage phase to phase, rotary field display ..... 28		
8.3	I /IN - Current / neutral conductor current, instantaneous and average value switch-over ..... 29		

9.9	Setting the relay on-delay and off-delay.....	56	1.9	Synchronization by the energy supplier's synchronous pulse.....	71
9.10	Activate daylight saving time .....	58	11.10	Synchronization by KBR eBus .....	71
9.11	Language settings .....	59	11.11	Synchronization at tariff change.....	72
9.12	Password .....	60	12	Technical data.....	73
9.13	Configuring the pulse output.....	61	12.1	Measuring and display values .....	73
9.14	Damping coefficient .....	63	12.2	Measurement accuracy.....	74
9.15	Default settings.....	64	12.3	Measuring principle .....	75
9.16	Zero point creator .....	65	12.4	Device memory.....	75
10	Reset and delete function .....	66	12.5	Power supply .....	75
10.1	Reset .....	66	12.6	Hardware inputs and outputs .....	76
10.2	Delete energy meter .....	66	12.6.1	Inputs.....	76
10.2.1	Delete energy meter manually ...	66	12.6.2	Outputs.....	76
10.2.2	Delete all energy meters .....	66	12.7	Electrical connection .....	77
10.3	Deleting extreme values .....	66	12.8	Mechanical data .....	78
10.3.1	Deleting individual extreme values.....	66	12.9	Ambient conditions, electrical safety and standards.....	79
10.3.2	Deleting all extreme values.....	67	12.10	Default settings after reset .....	80
10.4	Deleting limit settings .....	67	13	Serial interface .....	81
10.4.1	Deleting individual limit settings .....	67	13.1	RS 485 Schnittstellenbetrieb (only multimes F144-0-LED-EP-...-5) .....	81
10.4.2	Deleting all limit settings .....	67	13.2	RS 485 Busbetrieb (only multimes F144-1-LED-ESMS-...5) .....	81
11	Memory functions .....	68	14	Overvoltage and lightning protection.....	81
11.1	Device settings.....	68	15	Troubleshooting.....	82
11.2	Basic device parameters .....	68	16	Appendix.....	84
11.3	Long-term memory (only multimes F144-1-LED-ESMS-...-5) .....	69	16.1	Added functionality: Profibus.....	84
11.4	Load profile memory .....	69	16.2	Setting the bus protocol.....	84
11.5	Annual energy memory.....	69	16.3	Set Profibus bus address .....	85
11.6	Event memory .....	70			
11.7	Measurement period synchronization .....	70			
11.8	Synchronization only by internal clock.....	70			

## Dear customer

Thank you for choosing a KBR product.

To familiarize yourself with operation and configuration of the device, we recommend that you read this manual carefully. This will enable you to make use of the entire range of functions that this high-quality product offers.

The individual chapters serve to explain the technical details of the device and show how to properly install and start up the device to prevent damage.

This user manual is included in the scope of delivery of the device and must be accessible to the user at all times (e.g. in the switchgear cabinet). Even if the device is resold to third parties, the manual remains an inherent part of the device.

Although the utmost care has been taken in putting together this user manual, errors may still occur. We would be very grateful if you could notify us of any errors or unclear descriptions you may notice. The form included in the appendix to this manual can be used to send us corrections or suggested improvements.

Yours sincerely,

KBR GmbH Schwabach

This manual contains notes that must be observed for your personal safety and to avoid damage to the equipment. These notes are identified by a warning sign or information symbol, depending on the degree of hazard they warn about.



### DANGEROUS VOLTAGE

means that death, major injury or substantial property damage may occur if the appropriate safety measures are not taken.



### CAUTION

means that minor injuries or property damage may occur if the appropriate safety precautions are not taken.



### NOTE

is an important piece of information on the product, product handling or the respective part of the user manual to which special reference is made.

## Disclaimer

The contents of this manual have been checked to concur with the described hardware and software components. However, deviations may occur, meaning that no guarantee can be made for complete agreement with the documentation. The specifications given in this manual are checked on a regular basis; necessary corrections will be included in the next revision.

We appreciate your corrections and comments.

## Safety notes

In order to prevent operating errors, handling of the device has been kept as simple as possible. This will enable you to use the device very quickly. Be sure to carefully read the following safety notes.



## DANGEROUS VOLTAGE

### **The applicable DIN/VDE regulations must be observed for installation!**

Power supply connection, setup and operation of the device may only be performed by qualified personnel. Qualified personnel as defined in the safety notes in this user manual are personnel with electrical engineering qualifications, knowledge of the national accident prevention regulations and safety engineering standards as well as of the installation, commissioning and operation of the device.

To prevent fire and electric shock, do not expose the device to rain or moisture! Before connecting the device to the power supply, check whether the local power supply conditions comply with the specifications on the device nameplate.

A faulty connection may result in the destruction of the device!

When connecting the device, ensure that the data given in the connection chart is complied with (see "Connection diagram") and that the connection cables are not live. When wiring, always ensure that all wiring material used is neither damaged nor defective and that the polarity is correct!

For proper and safe product operation, ensure that the device is transported, stored, installed assembled, and carefully operated and maintained in accordance with the specifications.

A visibly damaged device must generally be considered unfit for use and disconnected from the power supply. Troubleshooting, repairs and maintenance work may only be carried out in our facilities or after contacting our service team.

Opening the device without authorization will render your warranty null and void. Correct operation can no longer be guaranteed!

Opening the device may expose live parts. Capacitors in the device may still be charged, even if the device has been disconnected from all sources of electricity. Do not operate open devices under any circumstances!

All input and output cables of systems that are at risk from lightning strikes must be fitted with lightning protection (see chapter "Protective measures" for recommendations).

Do not connect external sources of electricity to terminals 36-39, 60-63 and 90-92.

Only apply safe-to-touch extra-low voltage in accordance with UL/CSA/IEC 61010-1 to terminals 34 and 35. Maximum values see technical data.

## Product liability

### **You have purchased a high-quality product.**

Only components of the highest quality and maximum reliability are used.

Each device is subject to long-term testing before it is delivered.

For details on product liability, please refer to our general terms and conditions for electronic equipment.

The warranty on device properties applies only if the device has been operated in accordance with its intended use!

## Disposal

Devices that are faulty, obsolete or no longer used, must be properly disposed of.

If required, we will dispose of the devices for you.

## Scope of delivery

### **Included in the scope of delivery:**

- Measuring device
- CR2032 battery
- Connector set
- User manual
- Mounting material for the housing

# 1 Device memory, battery-buffered



## NOTE

Before the initial start-up of the device, please insert the backup battery first (as described in the following), as otherwise any data stored would be lost in the event of power failure.



## CAUTION

Caution: danger of explosion if battery is replaced incorrectly.

Inserting or replacing the backup battery (see image):

1. Disconnect the device from the power supply.
2. Remove the upper housing cover (frame) using a suitable tool (e.g. a small screwdriver).
3. Remove the front cover.
4. To replace it, remove the empty battery from the clamp pressing slightly against the contact spring using pliers.  
**Caution! To avoid a short circuit, the tips of the pliers have to be insulated.**
5. Press the new battery lightly against the contact spring and into the clamping bracket until it clicks into place. Ensure correct polarity!
6. Put the front cover back into place.
7. Put the device frame back into place and push until it clicks into place.
8. Reconnect the device to the power supply.



## NOTE

As there is no power supply if the battery is empty or removed, not only the stored data are lost but also the time is no longer correct. In this case, the time has to be reset in visual energy with the corresponding command (see section "Setting time and date" in the user manual).



Contact spring

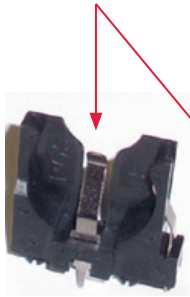

Battery holder

Battery

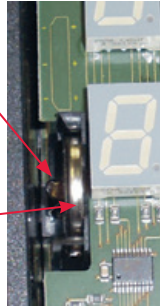

Front cover

Device frame

## 2 Definition of terms

Below, you will find a brief explanation of the terminology used in this manual.

Root mean square value:

By definition, the square mean value of a periodic or pulsating quantity is referred to as the RMS value.

The multimes **F144-0-LED-EP-...-5 / F144-1-LED-ESMS...-5** only uses the RMS values of periodic quantities.

Instantaneous root meansquare value:

The value determined by the **F144-0-LED-EP-...-5 / F144-1-LED-ESMS...-5** during its measurement interval.

Measurement interval:

During a measurement interval, the electrical quantity "voltage" or "current" of a phase is scanned. The resulting sampling points are available for further calculations. This interval is mainly determined by the A/D conversion.

Measuring cycle:

The measuring cycle is the time the measuring device needs in order to measure all the values recorded by the device for all three phases.

Firmware:

The operating system implemented in the microcontroller of the **F144-0-LED-EP-...-5 / F144-1-LED-ESMS...-5**.

Load profile memory:

Saves the actual values of the measurement periods with timestamp.

Measurement period maximum:

The measurement period containing the highest (maximum) value that occurred.

Active/reactive power periods:

Actual active or reactive power during a measurement period

Measurement period:

The period of time used to determine average power values. Typical intervals: e.g. 15, 30, 60 minutes.

## 3 Field of application / range of functions

The **multimes F144-0-LED-EP...-5 / F144-1-LED-ESMS...-5** is an affordable network measuring device for switchboard installation that measures all important parameters in three-phase networks.

The microprocessor of the **multimes F144-0-LED-EP...-5 / F144-1-LED-ESMS...-5** records the mains voltage and current consumption of the meter point for all three phases via analog/digital converter inputs and calculates the active, reactive and apparent power ratio in the three-phase network.

### Convenient operation and display

The LED displays L1, L2 and L3 allow you to read the measured values directly and enter the respective parameters and configuration data. In addition, eleven LEDs indicate menus and the status. Six sensor buttons facilitate navigation through the menus.

### For 100 to 400 V networks

The **multimes F144-0-LED-EP...-5 / F144-1-LED-ESMS...-5** can be used in 3-wire and 4-wire networks. The device can be used to make measurements directly in 100 V and 400V networks. Higher voltages can only be connected via external voltage transformers, with the primary and secondary voltage being programmable. The measuring voltage inputs of the device measure directly, i.e. they are not galvanically separated by a voltage transformer!

For energy supply networks with an outer conductor to ground potential, suitable ballasts with electrical isolation must be used, e.g. voltage transformers or zero point creators.

### x/5A or x/1A freely programmable

The current measurement inputs must always be supplied via current transformers; the transformer ratio is programmable. The primary current value as well as the secondary current value can be selected.

### Determining the neutral conductor current

The neutral conductor current is calculated and displayed.

### Harmonic analysis

Harmonic analysis by Fourier transform.

The **multimes F144-0-LED-EP...-5 / F144-1-LED-ESMS...-5** measures the harmonics of the 3rd / 5th / 7th / 9th / 11th / 13th / 15th / 17th and 19th voltage network harmonic, calculates their partial harmonic content, the total distortion factor of the voltage and the distortion reactive current.

### Two-tariff meter function (HT/LT)

Consumption during high tariff and low tariff times is recorded separately. Switching from high to low tariff times and vice versa is either carried out by means of a digital signal to be applied externally, e.g. from the energy supplier, or via an internal clock. When operated with the KBR Energy Bus, switching can be done centrally via the ve-busmaster.

### Programmable pulse output

Active energy or reactive energy proportional pulses can be output via a programmable S0 interface output. The pulse output type (proportional to active or reactive energy) as well as the pulse significance (number of pulses per kWh or per kvarh) and the pulse length can be programmed. These pulses can be processed by, for example, a master system for data acquisition or optimization, a maximum-demand monitor or a central process control.

### Serial interface

In its default configuration, the **multimes F144-1-LED-ESMS...-5** has a serial interface (RS485) for operation with the KBR Energy Bus.

A variety of information that cannot be shown on the display can be read from the device via the bus.

This makes it possible to read numerous online measurement values as well as a wide range of data can from the long-term memory.

### Extensive memory functions (only multimes F144-1-LED-ESMS...-5)

In addition to its meter functions, the **multimes F144-1-LED-ESMS...-5** offers extensive

#### memory functions:

- a load profile memory to record the cumulated active and reactive power
- a memory to record the daily energy values for 365 days
- and an event memory that records defined actions of the measuring device, such as power failures, tariff switching actions, delete functions and many more.

These memory functions are exclusively available via the KBR Energy Bus.

### Synchronization

To synchronize the load profile memory, a separate digital input was integrated into the **multimes F144-1-LED-ESMS...-5** where you can, for example, connect the synchronization signal of the energy supplier's meter. Synchronization as well as switching between high tariff and low tariff can be done centrally via the KBR Energy Bus or the internal clock.

### **Software (optional)**

A series of software products that run on most Microsoft® Windows® operating systems are available for the convenient programming and storage of long-term data.

### **Separate power supply**

The device requires a separate auxiliary voltage for operation.  
(see nameplate)

If you have any questions on this device or our software products, please don't hesitate to contact us. It is our pleasure to assist you.

See the cover of this user manual for contact details.

## **4 Connecting the multimess F144-0-LED-EP-...-5 multimess F144-1-LED-ESMS-...-5**

### **4.1 Installation and assembly**

- The applicable VDE regulations must be observed for installation!
- Before the device is connected to the power supply, check whether the local power supply conditions comply with the specifications on the nameplate. A faulty connection can destroy the device.  
A different power frequency can also affect the measurement.
- Connect the device in accordance with the connection diagram.
- The power supply input of systems that are at risk from lightning strikes must be equipped with suitable lightning protection.

### **4.2 Installation**

#### **Installation site:**

The device is designed to be installed in fixed and weatherproof switchboards. Conductive switchboards must be grounded.

#### **Installation position:**

vertical

#### **Fixing:**

Using the clamps provided, the device is attached to the switchboard from behind.

**CAUTION**

The control voltage as well as the applied measuring voltage of the device must be protected by means of a back-up fuse.

When connecting the current transformers, pay attention to the energy flow direction and the correct assignment to the voltage paths!

**Power supply:** The electrical installation of the building must have a disconnect or circuit-breaker for the power supply voltage.

The disconnect must be close to the device and be easily accessible to the user.

It must be marked as an isolating switch for this device.

The isolating switch must be UL/IEC-approved.

**Voltage measurement:**

The disconnect must be close to the device and be easily accessible to the user.

It must be marked as an isolating switch for this device. The isolating switch must be UL/IEC-approved.

**CAUTION**

Do not apply DC voltage to the voltage measurement input.

**CAUTION**

The device is not suitable for DC voltage measurement.

**CAUTION**

Attach the current transformer terminal to the device with two screws.

**CAUTION**

Never operate open external unloaded current transformers. Always short-circuit them. Risk of injury from high voltages and currents.

For the wiring of the pulse output, we recommend to exclusively use shielded twisted pair material to avoid disturbances (e.g. installation line I-Y(ST) Y 2 x 2 x 0.8 mm. The shielding may only be connected on one side).

During installation, please also observe our notes on safety measures against overvoltage and lightning in chapter "Protective measures" of this manual.



#### NOTE

Please observe the following when connecting the device to the three-phase network you want to measure:

- Energy flow direction
- Assignment of measuring voltage input / current transformer input

#### Rotary field:

The device can be operated with a clockwise or counter-clockwise rotary field. When switching on the device power supply, the multimes F144-0-LED-EP...-5 / F144-0-LED-ESMS...-5 automatically checks the direction of rotation. Rotary field check:

- Connect only the measuring voltage to the device (Umeas see nameplate).
- Switch on the device by applying voltage to the power supply connections (L and N). Immediately after the device has been switched on, it will check the power supply rotary direction.
- The rotary field is displayed in the menu UPH-PH, submenu Rotary field.
- For a clockwise rotary field, the display shows L1 0, L2 120 and L3 240 degrees.
- If you want to change the direction of rotation from clockwise to counter-clockwise, you only have to swap two terminals, i.e. two phases. Then, switch the device OFF and ON again. The display now shows the correct voltage and the device starts measuring automatically.
- Check again whether the assignment of the voltage path L1 and the current path L1 as well as all other phases are still correct.

**Current transformer connection:**

- Energy flow direction:

When installing the transformers, observe the current flow / energy flow direction. If the current transformer is installed the wrong way, the measured value will be negative.

The prerequisite for this is that energy be consumed.

- Assigning the measuring voltage input / current transformer input:

The current transformer on terminal 20/21 (k1/l1) must be installed in the phase in which the measuring voltage for terminal 10 (L1) is measured. The same applies to the other transformer and measuring voltage connections.

- With the **multimes F144-0-LED-EP...-5 / F144-0-LED-ESMS...-5**, you can check the phase sequence as follows:
  - Switch to the main menu "I"
  - Connect the current transformer to the corresponding wires
  - If connection and energy flow direction are correct, the device will only display positive currents.
  - If connections are wrong, all currents displayed will be negative. Interchange the connections until the display shows correct values.

**CAUTION**

Before any interchanging, the current transformers must be shorted out!



### 4.3 Connection diagram

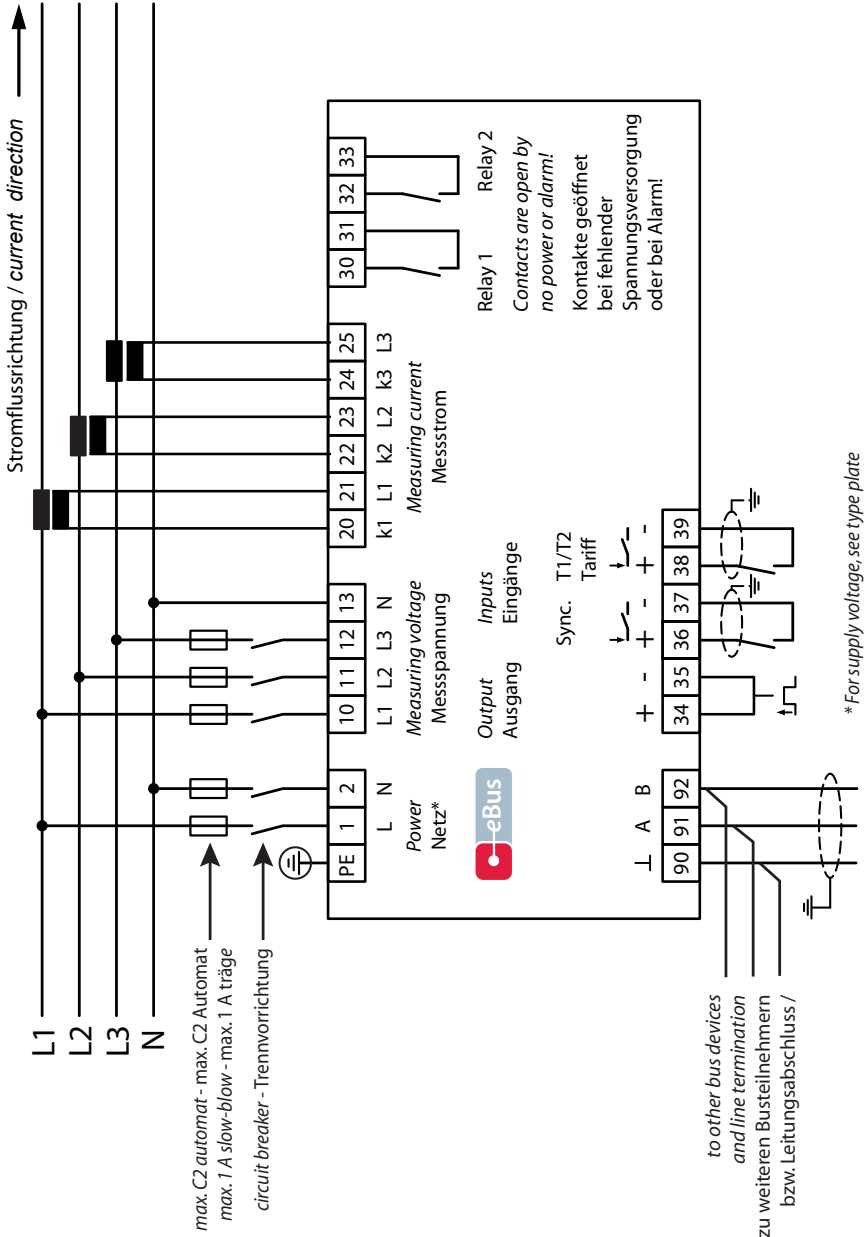

## 4.4 Terminal assignment

### Terminal

1 (L) and 2 (N):	<p><b>Power supply connection</b></p> <p>A control voltage is required to supply the device with power. The device has a multi-range power supply unit and can be supplied with different voltages (see nameplate).</p>
10 (L1) 11 (L2) 12 (L3) 13 (N)	<p><b>Voltage measurement inputs</b> Three-phase voltage measurement in 3-wire and 4-wire three-phase networks. Direct measurement for 3 x 5...100...120 V or 3 x 20...500...600 V AC. The measuring range is configurable. If the measuring range is exceeded, an error message is displayed. For higher voltages, the device needs to be connected via a voltage transformer.</p>
20 (k1) and 21 (l1) 22 (k2) and 23 (l2) 24 (k3) and 25 (l3)	<p><b>Current measurement inputs</b></p> <p>The current measurement inputs must be connected via current transformers x/1 A AC or x/5 A AC.</p> <p>When connecting transformers, pay attention to the energy flow direction and the correct assignment of measuring voltage inputs to the current transformers.</p>
30 and 31:	<p><b>Floating relay contact relay 1</b></p> <p>This contact serves as a message or alarm output. During operation, an acoustic or visual message can be activated or a consumer switched off with this relay. The contact is open as long as the device is dead as well as when there is an active message. Maximum switching capacity 2 A at 250 V AC (not safe to touch).</p>
32 and 33:	<p><b>Floating relay contact relay 2</b></p> <p>See description of floating relay contact relay 1</p>
90 (ground) 91 (A) 92 (B):	<p><b>Interface connection</b></p> <p>For eBus or Modbus communication.</p>
34 (+) and 35 (-):	<p><b>Pulse output</b></p> <p>Output of energy-proportional pulses via a digital contact (S0 interface in accordance with DIN 43864).</p> <p>Ensure that the output has the right polarity. The output signals can be processed by a maximum-demand monitor or a master central process control, for example.</p>

### Terminal

36 and 37:

**Synchronization input (only multimes F144-1-LED-ESMS...-5)**

A floating contact, e.g. from the energy supplier, can be connected to this input to synchronize the measurement period

38 (-) and 39 (+):







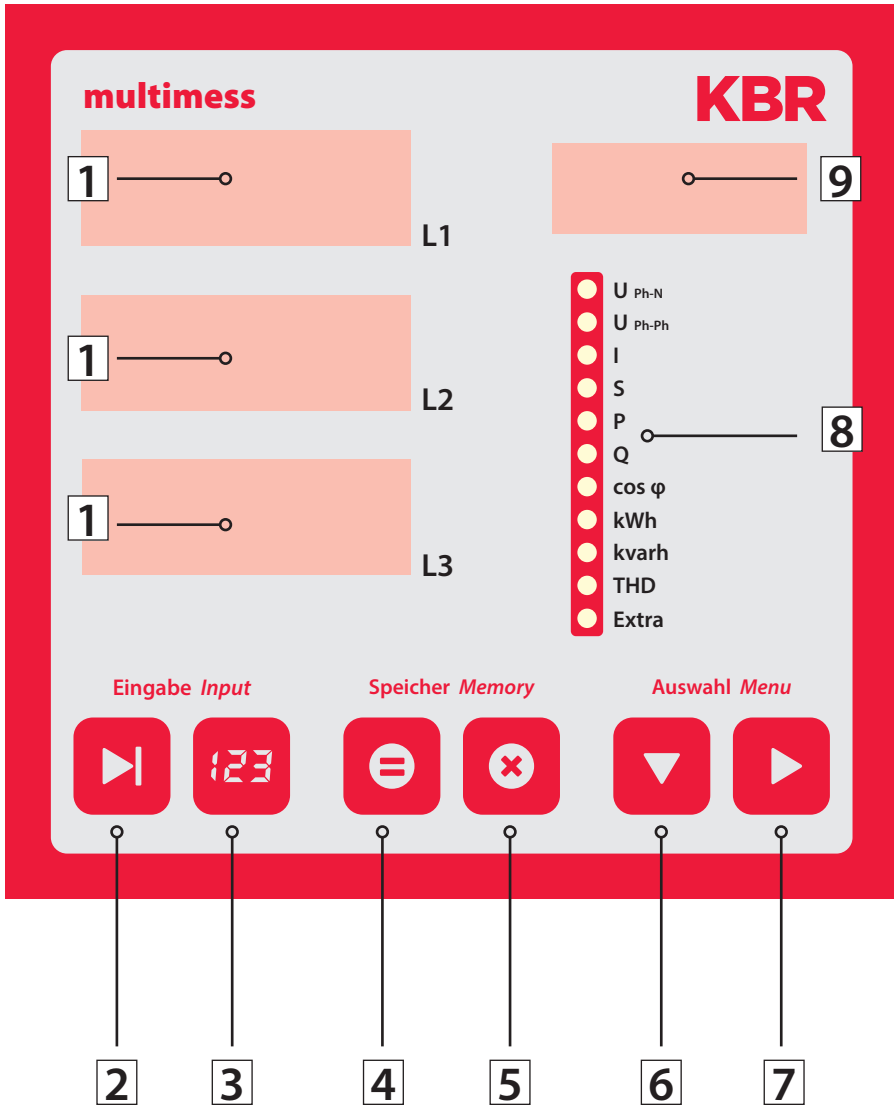

**Tariff input (only multimes F144-1-LED-ESMS...-5)**

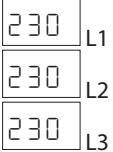
A floating contact, e.g. from the energy supplier, can be connected to this input to switch from high to low tariff.

## 5 Control and display panel



## 5.1 Description of sensor buttons and displays

<p><b>1</b></p>		<p>Three 4-digit 7-segment displays to show measured, stored and programmed values (3-phase; L1-L2-L3).</p>
<p><b>2</b></p>		<p>Starts the programming mode and switches between the segments to be edited in <b>1</b> and <b>9</b>. When you select a segment to edit it, it starts to flash.</p>
<p><b>3</b></p>		<p>In programming mode, this changes the flashing value in <b>1</b> or the decimal point in <b>1</b> and the unit prefix in <b>9</b>.</p>
<p><b>4</b></p>		<p>Display for saved minimum and maximum values. In programming mode, this saves the parameters or values entered.</p>
<p><b>5</b></p>		<p>Deletes the values displayed with <b>4</b>, such as extreme values, energy etc. In programming mode, you can use this button to cancel programming without applying any changes.</p>
<p><b>6</b></p>		<p>Selects one of the 11 main menus or jumps back from a submenu to the current main menu. Hold the button to automatically switch between the individual main menus. In programming mode, you can use this button to switch between the input fields L1, L2 and L3.</p>
<p><b>7</b></p>		<p>Jumps to the corresponding submenu.</p>
<p><b>8</b></p>		<p>There are 11 green LEDs, one for each main menu. A steady LED indicates the currently selected menu. If an LED is flashing, a limit in the corresponding menu has been violated. If the limit violation, however, occurred in the menu currently displayed, the LED does not flash.</p>
<p><b>9</b></p>		<p>The 4-digit 15-segment display shows information and dimensions of the values in <b>1</b>. When reading the saved extreme values, the display switches between the unit and MIN for minimum value or MAX for maximum value. This principle applies to other menus as well and will be described in the corresponding sections of this manual.</p>

## 6 Operation

### 6.1 Menu structure of the multimes F144-0-EP-...-5 / F144-1-LED-ESMS-...-5



Switches between the main menus.

When you are in a menu, the corresponding LED lights up (not flashing).

Hold the button to automatically switch between the individual main menus.

Press this button in a submenu to switch back to the corresponding main menu without applying any changes.



Switches to the corresponding submenu.



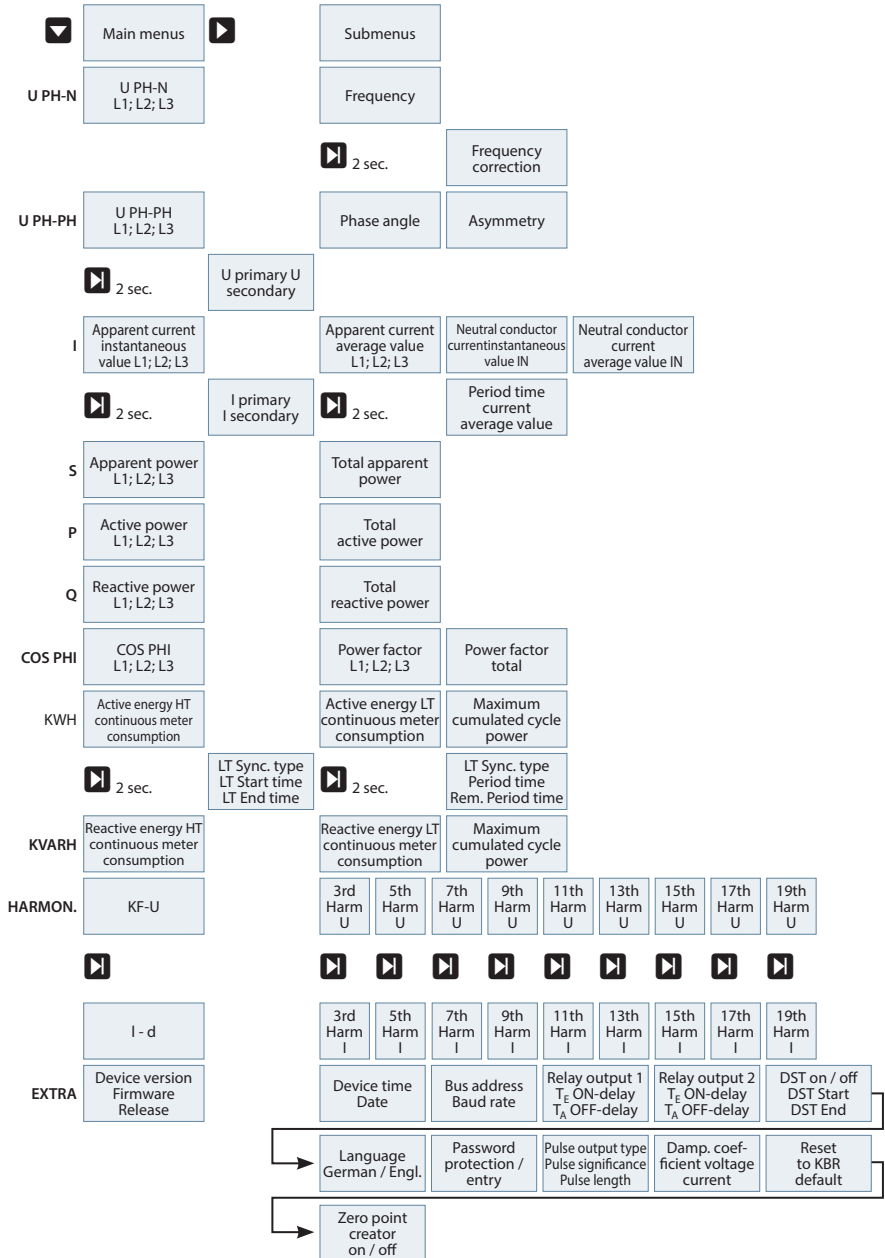

Press this button to switch from the last submenu back to the corresponding main menu.

## 6.2 Navigation and device displays



















## 7 Setting operating parameters



### 7.1 General programming scheme

	<ul style="list-style-type: none"> <li>▪ Press this button for 2 seconds to switch into the programming mode from a main menu or submenu. The set parameters are displayed.</li> <li>▪ Press this button again to activate the parameter input mode.</li> <li>▪ This button is also used to switch from one segment to the next when entering values.</li> </ul>
	<ul style="list-style-type: none"> <li>▪ Value input.</li> </ul>
	<ul style="list-style-type: none"> <li>▪ In programming mode, press this button to switch between the input fields L1, L2 and L3.</li> <li>▪ Return to the main menu after saving changes or canceling the programming mode.</li> </ul>
	<ul style="list-style-type: none"> <li>▪ This button is used to save changes.</li> </ul>
	<ul style="list-style-type: none"> <li>▪ Press this button if you want to cancel the programming mode without saving any changes.</li> </ul>



## 7.2 U Ph-Ph - Measuring reference voltage / rated mains voltage

Menu	Button(s)	Device display	Description
<b>Main menu</b> <b>UPh-Ph</b>			
Submenu Voltage	Hold the  button for 2 seconds	 L1  <small>○ U<sub>Ph-PH</sub> ● U<sub>Ph-PH</sub> ○ I ○ S ○ P ○ Q ○ cos φ ○ kWh ○ kvarh ○ Harmon. ○ Extra</small>	When you open the menu, the following text is shown in the unit display: <i>VOLTAGE TRANSFORMER RATIO UPRI / USEC V / V</i>
Set the transformer ratio	 Start input mode	 L2   L3	Display L1 shows the primary voltage. Display L2 shows the secondary voltage.
Submenu Voltage Set transformer ratio primary	 .....  next digit or  cancel or  save	 L1  <small>○ U<sub>Ph-PH</sub> ● U<sub>Ph-PH</sub> ○ I ○ S ○ P ○ Q ○ cos φ ○ kWh ○ kvarh ○ Harmon. ○ Extra</small>   L2   L3	The first digit in display L1 flashes. Press the  button to change the number. Press the  button to switch to the next digit. If all digits have been set, display L1 flashes. To move the decimal point, press the  button











Main menu  or   
U<sub>ph-ph</sub>





### NOTE









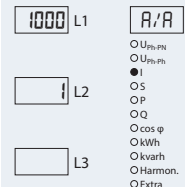

 or 

Use these buttons to switch between the individual displays in input mode (one flashing digit).

Submenu Voltage Set transformer ratio secondary	 .....  next digit or  cancel or  save	 L1  <small>○ U<sub>Ph-PH</sub> ● U<sub>Ph-PH</sub> ○ I ○ S ○ P ○ Q ○ cos φ ○ kWh ○ kvarh ○ Harmon. ○ Extra</small>   L2   L3	The first digit in display L2 flashes. Press the  button to change the number. Press the  button to switch to the next digit. The value can be set between 1 V and 600 V.
---	---	--	---

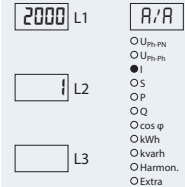





Main menu  or   
U<sub>ph-ph</sub>

### 7.3 I - Current transformer ratio

Menu	Button(s)	Device display	Description
Main menu I			
Submenu Current Set transformer ratio	Hold the  button for 2 seconds   Start input mode		When you open the menu, the following text is shown in the unit display: <i>A/A CURRENT TRANSFORMER IPRI / ISEC A/A</i> Display L1 shows the primary current. Display L2 shows the secondary current.
Submenu Current Set transformer ratio primary	 .....  next digit or  cancel or  save		The first digit is flashing in display L1. Press the  button to change this number. Press the  button to switch to the next digit. If all digits have been set, display L1 flashes. To move the decimal point, press the  button.

Main menu I  or **NOTE** or 

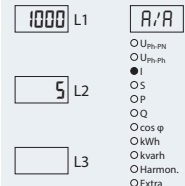
Use these buttons to switch between the individual displays in input mode (one digit flashes).

Submenu Current Set transformer ratio secondary	 .....  next digit or  cancel or  save		The first digit in display L2 flashes. Press  to switch between 1 A and 5 A.
---	---	---	---

Main menu I  or 

## 8 Display functions

### 8.1 UPh-N - Voltage phase to neutral conductor, frequency

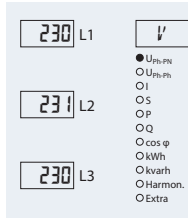
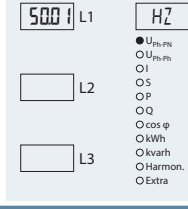
Menu	Button(s)	Device display	Description
<b>Main menu</b> $U_{Ph-N}$	 next		Displays the three phase voltages $U_{L1-N}$ , $U_{L2-N}$ and $U_{L3-N}$ in the displays L1 to L3.  The unit display shows the voltage unit.  The measuring range automatically switches from $V$ to $kV$ .
Submenu Frequency			Shows the instantaneous frequency in display L1.

Main menu

$U_{Ph-N}$







**8.2 UPh-Ph - Voltage phase to phase, rotary field display**

Menu	Button(s)	Device display	Description
Main menu $U_{Ph-Ph}$	next		<p>The three phase-to-phase voltages <math>U_{L1-L2}</math>, <math>U_{L2-L3}</math> and <math>U_{L3-L1}</math> are shown in the displays L1 to L3.</p> <p>The unit display shows the voltage unit.</p> <p>The measuring range automatically switches from V to kV.</p>
Submenu Rotary field	next		<p>Displays the three rotary field angles of the voltages.</p> <p>The unit display shows the unit "DEG"</p>
Submenu Asymmetry			<p>Display of voltage asymmetry according to the standard EN 6100-4-30:2003</p> <p>Shows the asymmetric load of the three-phase network.</p> <p>The unit display switches between ASYM and %.</p>
Submenu Asymmetry			

Main menu

 $U_{Ph-Ph}$ 

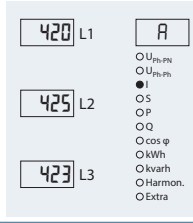
### 8.3 I /IN - Current / neutral conductor current, instantaneous and average value switch-over

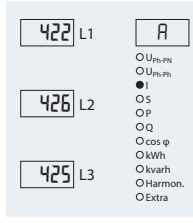
Menu	Button(s)	Device display	Description
			
Main menu I Instantaneous value	 next		<p>Displays the three conductor currents in the phases L1, L2 and L3. The values displayed are instantaneous values.</p> <p>The unit display switches between ACT and A.</p>
Submenu I Average value	 next or  Return to main menu		<p>Displays the three conductor currents in phases L1, L2 and L3. The values displayed are average values.</p> <p>The unit display switches between AVG and A.</p>



#### NOTE

A negative sign in front of the displayed current values indicates a negative current direction.

A positive sign indicates energy consumption.

A negative sign indicates energy recovery.

Menu	Button(s)	Device display	Description
Submenu $I_N$ Neutral conductor current			Display L1 shows the instantaneous neutral conductor current. The unit display switches between $NACT$ and $A$ .
Submenu $I_N$ Neutral conductor current  Average value	<input type="checkbox"/> next or <input checked="" type="checkbox"/> Return to main menu		Display L1 shows the average value of the neutral conductor current. The unit display switches between $N AVG$ and $A$ .

### 8.4 S - Apparent power / total apparent power

Menu	Button(s)	Device display	Description
	<input checked="" type="checkbox"/>		
Main menu S Apparent power	<input type="checkbox"/> next		The displays L1 to L3 show the apparent power of the three phases. The unit display shows the apparent power in $kVA$ . The device automatically switches from $VA$ to $kVA$ and $MVA$ .
Submenu Total apparent power			Shows the total apparent power in display L1. The unit display switches between $kVA$ and $STOT$ . The measuring range automatically switches from $VA$ to $kVA$ and $MVA$ .
Main menu S Apparent power	<input checked="" type="checkbox"/> or <input checked="" type="checkbox"/>		

### 8.5 P - Active power / total active power

Menu	Button(s)	Device display	Description
Main menu P Active power			<p>The displays L1 to L3 show the active power of the three phases.</p> <p>The unit display shows the active power in <i>KW</i>.</p> <p>The measuring range switches from W to kW and MW automatically.</p>
Submenu Total active power	or		<p>Shows the total active power in display L1.</p> <p>The unit display switches between PTOT and KW.</p> <p>The measuring range automatically switches from W to KW and MW.</p>
Main menu P Active power			

**8.6 Q - Reactive power / total reactive power**

Menu	Button(s)	Device display	Description
Main menu Q Reactive power			Displays L1 to L3 show the reactive power of the three phases. An "i" in front of a value indicates inductive, a "c" indicates capacitive reactive power. The unit display shows the reactive power in <i>KVAR</i> . The measuring range automatically switches from <i>VAR</i> to <i>KVAR</i> and <i>MVAR</i> .
Submenu Total reactive power			Shows the total reactive power in display L1. An "i" in front of a value indicates inductive, a "c" indicates capacitive reactive power. The unit display switches between <i>QTOT</i> and <i>KVAR</i> . The measuring range automatically switches from <i>VAR</i> to <i>KVAR</i> and <i>MVAR</i>
Main menu Q Reactive power	or		



### 8.7 Cos φ - Fundamental power factor, PF, total PF

Menu	Button(s)	Device display	Description
	<input checked="" type="checkbox"/>		
Main menu Cos φ	<input type="checkbox"/> next		<p>Display of cosφ.</p> <p>Display L1 shows the cosφ for phase L1. (i = inductive, c = capacitive)</p> <p>Display L2 shows the cosφ for phase L2. (i = inductive, c = capacitive)</p> <p>Display L3 shows the cosφ for phase L3. (i = inductive, c = capacitive) The unit display shows COS.</p> <p>(The cosφ displayed refers to the fundamental)</p>
Submenu Power factor	<input checked="" type="checkbox"/> next		<p>Display of the power factor PF.</p> <p>Display L1 shows the power factor 1 for the phase L1. Display L2 shows the power factor 2 for phase L2. Display L3 shows the power factor 3 for phase L3. The unit display shows PF.</p>
Submenu Total PF			
Submenu Total PF			<p>Displays the power factor total.</p> <p>Display L1 shows the power factor total.</p> <p>The unit display switches between TOT and PF.</p>

Main menu  
Cos φ





### 7.8 kWh - Active energy HT/LT consumption, maximum cumulated cycle active power

Menu	Button(s)	Device display	Description
	<input checked="" type="checkbox"/>		
Main menu kWh Active energy High tariff Consumption	<input type="checkbox"/> next		Active energy meter for high tariff consumption. Display L3 - L1 shows the value of the continuous energy meter.  The unit display switches between HT and KWh.  1234 Display L1 (G Wh display) 567 Display L2 (M Wh display) 890.1 Display L3 (k Wh display)
Submenu kWh Active energy Low tariff Consumption	<input type="checkbox"/> next or  <input checked="" type="checkbox"/> Return to main menu		Active energy meter for low tariff consumption. Display L3 - L1 shows the value of the continuous energy meter.  The unit display switches between LT and KWh.  1234 Display L1 (G Wh display) 567 Display L2 (M Wh display) 890.1 Display L3 (k Wh display)

Continued

Menu	Button(s)	Device display	Description
Submenu PCum-Max Maximum cu- mulated cycle power			<p>When you open the menu, the following text is shown in the unit display: PCUMX MAXIMUM CUMULATED POWER IN PERIOD Then the unit display switches between PCUMX and kWh</p> <p>Display L1 shows the period value.</p> <p>Display L2 shows the exact time the maximum occurred (hh:mm).</p> <p>Display L3 shows the day and month, alternating with the year, of the maximum (dd.mm.yyyy).</p>

Main menu  or   
kWh

## 8.9 kvarh - Reactive energy counter HT/LT consumption, maximum cumulated cycle reactive power

Menu	Button(s)	Device display	Description
	<input checked="" type="checkbox"/>		
Main menu kvarh Reactive energy High tariff Consumption	<input type="checkbox"/> next	<p>The device display shows three numerical displays: L1 (1234), L2 (567), and L3 (890.1). To the right, a unit display shows 'kWh'. Below the unit display is a list of options with radio buttons: U<sub>rms,PH</sub>, U<sub>rms,EN</sub>, OI, OS, OP, OQ, Ocos φ, O kWh, ● kvarh, O Harmon., and O Extra.</p>	Reactive energy meter for high tariff consumption. Display L3 - L1 shows the value of the reactive energy continuous meter. The unit display switches between HT and kWh.  1234 Display L1 (G varh display) 567 Display L2 (M varh display) 890.1 Display L3 (k varh display)
Submenu kvarh Reactive energy Low tariff Consumption	<input type="checkbox"/> next or   <input checked="" type="checkbox"/> Return to main menu	<p>The device display shows three numerical displays: L1 (1234), L2 (567), and L3 (890.1). To the right, a unit display shows 'kWh'. Below the unit display is a list of options with radio buttons: U<sub>rms,PH</sub>, U<sub>rms,EN</sub>, OI, OS, OP, OQ, Ocos φ, O kWh, ● kvarh, O Harmon., and O Extra.</p>	Reactive energy meter for low tariff consumption. Display L3 - L1 shows the value of the reactive energy continuous meter. The unit display switches between LT and kWh.  1234 Display L1 (G varh display) 567 Display L2 (M varh display) 890.1 Display L3 (k varh display)

Continuation of table 8.9

Menu	Button(s)	Device display	Description
Submenu QCum-Max Maximum cumulated cycle power			<p>When you open the menu, the following text is displayed in the unit display:  <b>QCMX MAXIMUM CUMULATED POWER IN PERIOD</b></p> <p>Then the unit display switches between <b>QCMX</b> and <b>KVARH</b>.</p> <p>Display L1 shows the period value.</p> <p>Display L2 shows the exact time the maximum occurred (hh:mm).</p> <p>Display L3 shows the day and month, alternating with the year, of the maximum (dd.mm.yyyy).</p>

Main menu or   
kvarh



**NOTE (only multimes F144-1-LED-ESMS...-5)**

The daily energy meters (for active and reactive energy) of the device can only be read out via the KBR Energy Bus with the optionally available software.

## 8.10 Harmon. - distortion factor and partial oscillation of the network harmonics for voltage and current.

Measuring the current harmonics is only possible with the multimes F144-1-LED-ESMS...-4 device type..

Menu	Button(s)	Device display	Description
Main menu Harmon. Voltage distortion factor	<p> next or</p> <p> Switch to the current harmonics</p> <p>or</p> <p> Return to main menu</p>		<p>Display L1 shows the distortion factor in % for the voltage of phase L1.</p> <p>Display L2 shows the distortion factor in % for the voltage of phase L2.</p> <p>Display L3 shows the distortion factor in % for the voltage of phase L3.</p> <p>The unit display switches between <math>\text{DF}</math> and <math>\text{‰}/\text{a}</math>.</p>
Submenu 3rd-19th harmon.	<p> next or</p> <p> Switch to the current harmonics</p> <p>or</p> <p> Return to main menu</p>		<p>Displays the 3rd harmonic.</p> <p>Display L1 shows the 3rd harmonic in % for the voltage of phase L1.</p> <p>Display L2 shows the 3rd harmonic in % for the voltage of phase L2.</p> <p>Display L3 shows the 3rd harmonic in % for the voltage of phase L3.</p> <p>The unit display switches between <math>3rd U</math> and <math>\text{‰}/\text{a}</math>.</p> <p>The subsequent harmonics (5th – 19th) are displayed in the same way.</p> <p>For example, when displaying the current harmonic, the display switches between <math>3rd I</math> and <math>I</math>; when displaying the distortion current strength, it switches between <math>I_d</math> and <math>I</math>.</p>



### NOTE (only multimes F144-1-LED-ESMS...-5)

Use the button to switch between the voltage harmonics and current harmonics anywhere in the menu.  
The current harmonics are displayed in amperes.

### 8.11 Extra

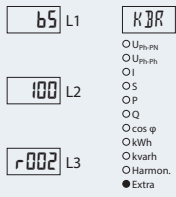
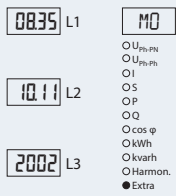
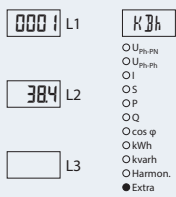
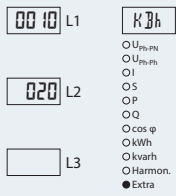
Menu	Button(s)	Device display	Description
	<input checked="" type="checkbox"/>		
Main menu Extra	<input type="checkbox"/> next		<p>Display L1 shows the device type (here: Basic).</p> <p>Display L2 shows the version number. Display L3 shows the release number. The unit display shows the name of the device.</p>
Submenu Date and time	<input type="checkbox"/> next or <input checked="" type="checkbox"/> Return to main menu		<p>Display L1 shows the time (hh.mm). Display L2 shows the date (dd.mm). Display L3 shows the year (yyyy).</p> <p>The unit display shows the week-day.</p>
Submenu eBus  only multimess F144-1-ESMS...-5	<input type="checkbox"/> next or <input checked="" type="checkbox"/> Return to main menu		<p>Display L1 shows the device address.</p> <p>The baud rate is shown in display L2.</p> <p>The unit display shows eBus.</p>
Submenu REL 1	<input type="checkbox"/> next or <input checked="" type="checkbox"/> Return to main menu		<p>Display L1 shows the on-delay for relay 1 in seconds. Display L2 shows the off-delay for relay 1 in seconds. The unit display switches between REL 1 and TON.</p>

Continued

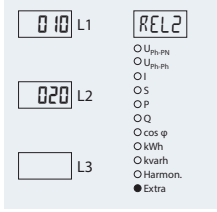
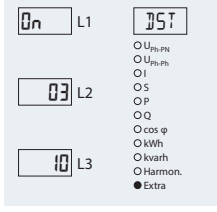
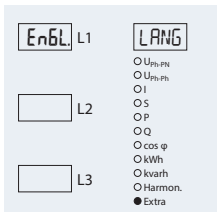
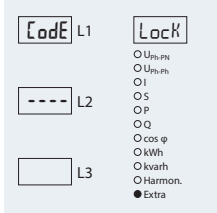
Menu	Button(s)	Device display	Description
Submenu REL 2	<input type="checkbox"/> next or  <input checked="" type="checkbox"/> Return to main menu		<p>Display L1 shows the on-delay for relay 2 in seconds.</p> <p>Display L2 shows the off-delay for relay 2 in seconds.</p> <p>The unit display switches between REL2 and TON.</p>
Submenu Daylight saving time	<input type="checkbox"/> next or  <input checked="" type="checkbox"/> Return to main menu		<p>Display L1 indicates whether daylight saving time is activated or not.</p> <p>Display L2 shows the month daylight saving time begins.</p> <p>Display L3 shows the month daylight saving time ends.</p> <p>The unit display shows DAYLIGHT-SAVING PARAMETER and then DST.</p>
Submenu Language	<input type="checkbox"/> next or  <input checked="" type="checkbox"/> Return to main menu		<p>Display L1 shows the user language. For German, it displays DEUT. For English ENGL.</p> <p>The unit display shows SPRA if the user language is German and LANG for English.</p>
Submenu Password	<input type="checkbox"/> next or  <input checked="" type="checkbox"/> Return to main menu		<p>Display L1 shows CODE.</p> <p>The unit display shows LOCK or FREE.</p> <p>You can enter the password in L2. (4-digit code)</p> <p>The device is defaulted with the code 9999, i.e. all functions of the device are available.</p>



Continued

Menu	Button(s)	Device display	Description
Submenu Pulse output	▶ next or  ☑ Return to main menu		<p>Display L1 indicates whether the pulse output is deactivated (OFF) or configured for active (P) or reactive (Q) energy.</p> <p>Display L2 shows the pulse significance, i.e. pulse/kWh or kvarh.</p> <p>Display L3 displays the energy pulse length in ms.</p>
Submenu Damp. coefficient	▶ or ☑		<p>Display L1 shows the damping coefficient for acquiring the voltage.</p> <p>Display L2 shows the damping coefficient for acquiring the current.</p>
Main menu Extra			
Submenu Reset to default settings	▶ next or  ☑ Return to main menu		<p>The device is reset to the default KBR factory settings. All stored values are lost.</p> <p>The unit display shows <i>DEFAULT PARAMETER</i> and then <i>DEF.</i></p>
Submenu Zero point creator	▶ next or  ☑ Return to main menu		<p>Display L1 shows <i>OFF</i> if it is deactivated. If the zero point creator is activated, <i>ON</i> is displayed.</p> <p>The unit display shows <i>ZERO-POINT CREATOR</i> and then <i>0-P.</i></p>

### 8.12 Maximum / Minimum extreme values display

The following section explains how to display the extreme values. The maximum and minimum values of the phase voltages will be used as an example.

Menu	Button(s)	Device display	Description
Main menu U <sub>Ph-N</sub> Voltage Maximum	<input type="button" value="▶"/> next or  <input checked="" type="checkbox"/> Return to main menu		<p>The maximum values that occurred for the phase to neutral voltages are shown in the displays L1 to L3 for each phase.</p> <p>The unit display switches between <b>MA%</b> and <b>V</b>.</p>
Voltage Maximum	<input type="button" value="▶"/> next or  <input checked="" type="checkbox"/> Return to main menu		<p>The time the maximum values occurred for the phase to neutral voltages are displayed in the displays L1 to L3.</p> <p>The unit display switches between <b>MA%</b> and <b>TIME</b>.</p>
Voltage Maximum	<input type="button" value="▶"/> next or  <input checked="" type="checkbox"/> Return to main menu		<p>The day the maximum values occurred for the phase to neutral voltages are shown in the displays L1 to L3.</p> <p>The unit display switches between <b>MA%</b> and <b>DAT</b>.</p>
Voltage Maximum			<p>The year the maximum values occurred for the phase to neutral voltages are displayed in the displays L1 to L3.</p> <p>The unit display switches between <b>MA%</b> and <b>DAT</b>.</p>

Main menu  
U<sub>Ph-N</sub>  or



**NOTE**

Use the  button to switch from maximum to minimum values.  
The minimum values are read the same way as the maximum values.

The following table gives an overview of all extreme values stored in the multimess F144-0-LED-EP...-5 / F144-1-LED-ESMS...-5.

Stored extreme values with date and time they occurred.







Menu	Measured value	Stored extreme values	Text displayed in de and en
Main menu $U_{Ph-N}$	Phase-to-neutral voltage	Minimum and maximum value of L1 - L2 - L3 with date and time	Min and Max
Submenu $F_{power}$	Network frequency	Minimum and maximum value of L1 with date and time	Min and Max
Main menu $U_{Ph-Ph}$	Phase-to-phase voltage	Minimum and maximum value of L1 - L2 - L3 with date and time	Min and Max
Main menu $I_{act}$	Phase current instantaneous values	Minimum and maximum value of L1 - L2 - L3 with date and time	Min and Max
Submenu $I_{avg}$	Average values for phase current	Minimum and maximum value of L1 - L2 - L3 with date and time	Min and Max
Submenu $I_{nact}$	Average neutral conductor current	Minimum and maximum of the average neutral conductor current with date and time	Min and Max
Main menu S	Apparent power	Minimum and maximum value of L1 - L2 - L3 with date and time	Min and Max
Submenu $S_{TOT}$	Total apparent power	Minimum and maximum value of the total apparent power with date and time	Min and Max
Main menu P	Active power	Minimum and maximum value of L1 - L2 - L3 with date and time	Min and Max
Submenu $P_{TOT}$	Total active power	Minimum and maximum value for total apparent power with date and time	Min and Max
Main menu Q	Reactive power	Minimum and maximum value of L1 - L2 - L3 with date and time	Min and Max
Submenu $Q_{TOT}$	Total reactive power	Minimum and maximum value for total reactive power with date and time	Min and Max
Main menu $COS \varphi$	Fundamental power factor	Minimum and maximum value of L1 - L2 - L3 with date and time	Min and Max
Submenu Power factor	Power factor	Minimum and maximum value of L1 - L2 - L3 with date and time	Min and Max

Continued

Menu	Measured value	Stored extreme values	Text displayed in de and en
Submenu Total PF	Power factor total	Minimum and maximum value of the power factor total with date and time	Min and Max
Main menu Harmon.	Harmonics	Maximum values of the distortion factor of the voltage and the 3rd -19th network harmonic as well as the current harmonic contents and their sum; L1-L3.  (harmonics only multimes F144-1-LRED-ESMS-...-5)	Max

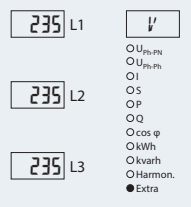
### 8.13 Displaying limits

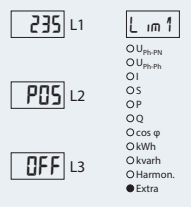
Using the example of limits 1 and 2 of the phase voltage, the following section explains how to display limits.

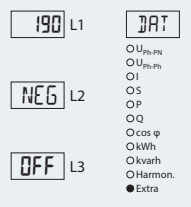
Menu	Button(s)	Device display	Description
Main menu $U_{Ph-N}$ Submenu Voltage Maximum	  Return to main menu		The maximum values that occurred for the phase to neutral voltages are shown in the displays L1 to L3 for each phase.  The unit display switches between MA% and V .
Submenu Limit 1	 go to limit 2 or       <input checked="" type="checkbox"/> Return to main menu		Display L1 shows the limit. Display L2 shows the direction of the limit. (POS: value must not exceed this limit; NEG: value must not fall below this limit; OFF: limit deactivated.) Display L3 shows the message type for the limit: OFF message only via KBR Energy Bus: rEL 1 additional message at relay 1 rEL 2 additional message at relay 2  If a limit is violated, the LED of the respective main menu starts to flash.
Submenu Limit 2	 go to limit 1 or    <input checked="" type="checkbox"/> Return to main menu		Description see limit 1

The following table gives an overview of all limits available in the  
**multimes F144-0-LED-EP / F144-1-LED-ESMS...-5.**









Menu	Measured value	Programmed limits	Text displayed in de and en
Main menu $U_{Ph-N}$	Phase-to-neutral voltage	Limit 1 and limit 2 for L1 - L2 - L3	GW 1 and GW 2 Lim 1 and Lim 2
Submenu $F_{power}$	Network frequency	Limit 1 and limit 2	GW 1 and GW 2 Lim 1 and Lim 2
Main menu $U_{Ph-Ph}$	Phase-to-phase voltage	Limit 1 and limit 2 for L1 - L2 - L3	GW 1 and GW 2 Lim 1 and Lim 2
Main menu $I_{act}$	Phase current instantaneous values	Limit 1 and limit 2 for L1 - L2 - L3	GW 1 and GW 2 Lim 1 and Lim 2
Submenu $I_{avg}$	Average values for phase current	Limit 1 and limit 2 for L1 - L2 - L3	GW 1 and GW 2 Lim 1 and Lim 2
Submenu $I_{nact}$	Instantaneous value of neutral conductor current	Limit 1 and limit 2 for the instantaneous neutral conductor current	GW 1 and GW 2 Lim 1 and Lim 2
Submenu $I_{Navg}$	Average neutral conductor current	Limit 1 and limit 2 for the average neutral conductor current	GW 1 and GW 2 Lim 1 and Lim 2
Main menu S	Apparent power	Limit 1 and limit 2 for L1 - L2 - L3	GW 1 and GW 2 Lim 1 and Lim 2
Submenu $S_{TOT}$	Total apparent power	Limit 1 and limit 2 for total apparent power	GW 1 and GW 2 Lim 1 and Lim 2
Main menu P	Active power	Limit 1 and limit 2 for L1 - L2 - L3	GW 1 and GW 2 Lim 1 and Lim 2
Submenu $P_{TOT}$	Total active power	Limit 1 and limit 2 for total active power	GW 1 and GW 2 Lim 1 and Lim 2
Main menu Q	Reactive power	Limit 1 and limit 2 for L1 - L2 - L3	GW 1 and GW 2 Lim 1 and Lim 2
Submenu $Q_{TOT}$	Total reactive power	Limit 1 and limit 2 for total reactive power	GW 1 and GW 2 Lim 1 and Lim 2
Main menu $COS\phi$	Fundamental power factor	Limit 1 and limit 2 for L1 - L2 - L3	GW 1 and GW 2 Lim 1 and Lim 2

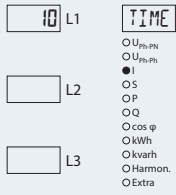

Continued

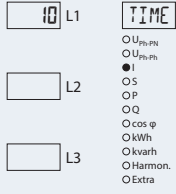
Menu	Measured value	Programmed limits	Text displayed in de and en
Submenu Power factor	Power factor	Limit 1 and limit 2 for L1 - L2 - L3	GW 1 and GW 2 Lim 1 and Lim 2
Submenu Total PF	Power factor total	Limit 1 and limit 2 for the power factor total	GW 1 and GW 2 Lim 1 and Lim 2
Main menu Harmon.	Harmonics	Limit 1 and 2 of the distortion factor of the voltage and the 3rd to 19th network harmonic of L1-L3 as well as the current harmonic contents and their sum L1 - L3	GW 1 and GW 2 Lim 1 and Lim 2

## 9 Programming

### 9.1 Period time current average value

Menu	Button(s)	Device display	Description
Main menu I <sub>act</sub> Submenu I average	Hold the  button for 2 seconds.		When you open the menu, the following text is shown in the unit display: TIME AVERAGE CURRENT TIME
Period time	 Start input mode		Display L1 shows the period time in minutes.
Submenu I Average value	 ...  next digit or  cancel		The first digit in display L1 flashes. Press the  button to set the number in this segment.
Setting the period time	or  save		Press the  button to switch to the next digit. You can set between 1 and 15 minutes.

Main menu  or   
I<sub>act</sub>

### 9.2 Tariff switching method

Tariff switching is only possible with the **multimess 4F144-0-LED-EP...-5** by internal clock.







Menu	Button(s)	Device display	Description
Main menu Main menu kWh/HT Sub-menu Tariff input Tariff switching method	Hold the  button for 2 seconds.		When you open the menu, the following text is shown in the unit display: <b>TARF LT TARIFF TIMES</b> Display L1 shows the tariff switching method. The following switching methods can be selected: <ul style="list-style-type: none"><li>- <b>dIn</b> by external pulse (only multimess F144-1-LED-ESMS...-5)</li><li>- <b>bUS</b> via Energy Bus command (only multimess F144-1-LED-ESMS...-5)</li><li>- <b>InT</b> by internal time program</li></ul>
Submenu tariff input	next modes		Display L1 flashes.
Set tariff switching method	next digit or save		Press the  button to switch between the above operating modes. The unit display switches between <b>TARF</b> and <b>TYP</b> .
Main menu kWh	or		
Main menu kWh /HT Sub-menu Tariff input Set tariff switching time	Set start time L3 flashes Set end time cancel or save		Display L2 flashes. Press the  button to set the start or end time.
Main menu kWh/HT	or		

28080\_LED0A0323-2023-1\_EN

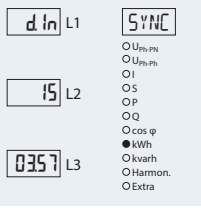

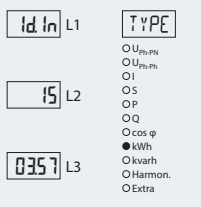
### 9.3 Measurement period synchronization

(only multimes F144-1-LED-ESMS...-5)

Menu	Button(s)	Device display	Description
Submenu kWh/LT Submenu Measurement period	Hold the  button for 2 seconds		<p>When you open the menu, the following text is shown in the unit display:  <b>SYNC PARAMETER SYNC</b></p> <p>Display L1 shows the synchronization type.</p> <p>Display L2 shows the measurement period in minutes.</p> <p>The time remaining until the next synchronization is indicated in display L3 in minutes and seconds.</p> <p>The following synchronization types can be selected:</p> <ul style="list-style-type: none"> <li>- <b>InT</b> by internal clock</li> <li>- <b>dIn</b> by external contact</li> <li>- <b>bUS</b> via Energy Bus command</li> <li>- <b>Ta rF</b> by tariff switching</li> </ul>
Submenu Measurement period	 .....		<p>Display L1 flashes.</p> <p>Press the  button to switch between the above operating modes.</p>
Set measurement period synchronization	 cancel or  save		

Main menu kWh

 or 



#### NOTE

In case of internal synchronization, you can restart the measurement period (in the kWh/LT submenu) by pressing the  button (for about 2 seconds)!

### 9.4 Programming limits

The following section explains how to parameterize the limits. The limits 1 and 2 of the phase voltage serve as an example.

Menu	Button(s)	Device display	Description
Submenu Voltage $U_{Ph-N}$	Hold the  button for 2 seconds.		Display L1 shows the limit value.  Display L2 shows the effective direction of the limit. (POS: value must not exceed this limit; NEG: value must not fall below this limit; OFF: limit deactivated.)
Maximum	Start input mode		
Submenu Voltage $U_{Ph-N}$			The first digit in display L1 flashes. Press the  button to set the number in this segment.
Limit 1 Set value	..... next digit or cancel or save		Press the  button to switch to the next digit.  Once all digits have been set, display L1 flashes.  To position the decimal point, press the  button.  The unit display switches between LIM 1 and V.

Main menu  
 $U_{Ph-N}$  or

or

**NOTE**

Use these buttons to switch between the individual displays in input mode (one flashing digit).

Menu	Button(s)	Device display	Description
Submenu Voltage $U_{Ph-N}$	▶ next digit or ⊗ cancel or ⊞ save		Display L2 flashes. Press the <b>123</b> button to select whether the limit is to be activated when exceeded ( <b>P05</b> ) or when the value falls below the limit ( <b>nE6</b> ) or whether it should be locked ( <b>OFF</b> ).
Limit 1 Set direction			

Main menu  
 $U_{Ph-N}$  ▶ or ▼



▶ or ▼

**NOTE**

Use these buttons to switch between the individual displays in input mode (one flashing digit).

Submenu Voltage $U_{Ph-N}$	▶ next digit or ⊗ cancel or ⊞ save		Display L3 flashes. Use the <b>123</b> button to determine the message type for a limit violation. - Alarm on relay 1 (rel1) - Alarm on relay 2 (rel2) - Alarm only via KBR Energy Bus ( <b>OFF</b> )
Limit 1 Set message type			

Main menu  
 $U_{Ph-N}$  ▶ or ▼

### 9.5 Setting time and date

Menu	Button(s)	Device display	Description
Main menu Extra  Submenu Date and time	<input checked="" type="checkbox"/> Start input mode		Display L1 shows the time (hh.mm). Display L2 shows the date (dd.mm). Display L3 shows the year (yyyy). The unit display shows the week-day.
Submenu Set date and time	<input type="checkbox"/> next modes  <input type="checkbox"/> next digit or <input type="checkbox"/> save		The first two digits in display L1 flash.  Press the  button to set the numbers of these segments.  Press the  button to switch to the next digit.  To set the day and month in display L2, proceed as described for display L1. The same applies to the year in display L3.

Main menu  
 Extra  or



#### NOTE

Use these buttons to switch between the individual displays in input mode (one flashing digit).

## 9.6 Setting the bus address

(only multimes F144-1-LED-ESMS...-5)

Menu	Button(s)	Device display	Description
Main menu Extra			Display L1 shows the device address. The baud rate is displayed in display L2.
Submenu eBus	▼ Start input mode (bus scan)		
Submenu eBus			Display L1 indicates that the device is in scan mode.
Assign address	▼ Start input mode		As soon as the device is recognized at the bus, it is automatically assigned an address by the software and this address is entered in the device memory. The baud rate is displayed in display L2.
 NOTE			Use these buttons to switch between the individual displays in input mode (one flashing digit).
Submenu eBus	123 Set start time ▼ L3 flashes 123 Set end time ⊗ cancel or ⏪ save		The first two digits in display L1 flash.
Assign address manually			Press the 123 button to set the value of these digits. Press the ▶ button to switch to the next digit.

Main menu  
Extra



### 9.7 Setting the bus protocol (only multimes F144-1-LED-ESMS...-5)

Menu	Button(s)	Device display	Description
Submenu eBus	<input checked="" type="checkbox"/> Start input mode (bus scan)		Display L1 shows the device address. The baud rate is displayed in display L2. The unit display shows the current bus protocol. (e.g. eBus).
Submenu eBus Assign address	<input checked="" type="checkbox"/> Start input mode		The first digit in display L1 flashes. Press the  button to enter the input mode to set the bus protocol.
Submenu eBus Assign bus protocol	<input checked="" type="checkbox"/> <input checked="" type="checkbox"/> ..... select cancel or save		Display L1 shows the device address. The baud rate is displayed in display L2. The unit display flashes. Press the  button to choose from different bus protocols. (eBus or Modbus).

Main menu  
Extra or

### 9.8 Setting the Modbus bus address and baud rate

(only multimess F144-1-LED-ESMS...-5)

Menu	Button(s)	Device display	Description
Submenu Modbus	Start input mode		Display L1 shows the device address. The baud rate is displayed in display L2. Display L3 shows the selected bus protocol (RTU or ASC).
Submenu Modbus  Assign address	..... next digit or cancel or save		The first digit in display L1 flashes. Press the  button to set the number of this segment. Press the  button to switch to the next digit.

Main menu

Extra or

Submenu Modbus  Assign baud rate	next baud rate cancel or save		Display L2 flashes. Press the  button to choose from different baud rates with the respective even/odd parity or no parity.  4.8 k baud    9.6 k baud    19.2 k baud
---	--	--	--

Main menu

Extra or

Submenu Modbus  Assign transmission mode	next baud rate cancel or select save		Display L3 flashes. Press the  button to choose between the different modes (RTU or ASC).
---	--	--	---

Main menu

Extra or

### 9.9 Setting the relay on-delay and off-delay

Menu	Button(s)	Device display	Description
Submenu REL 1	Start input mode	  	Display L1 shows the on-delay for relay 1 in seconds. Display L2 shows the off-delay for relay 1 in seconds. The unit display switches between REL 1 and TON.
Submenu REL 1 Set on-delay	..... next digit or cancel or save	  	The first digit in display L1 flashes. Press the  button to set the number of this segment. (max. 255 seconds).  Press the  button to switch to the next digit.

Main menu  
Extra or

or Use these buttons to switch between the individual displays in input mode (one flashing digit).

**NOTE**

Submenu REL 1 Set off-delay	..... next digit or cancel or save	  	The first digit in display L2 flashes. Press the  button to set the number of this segment. (max. 255 seconds).  Press the  button to switch to the next digit.  The assignment as switching relay is shown in display L1 ----, L2 ---- and L3 BUS.  Configuration is only possible via eBus using optionally available software.
-----------------------------------	---	----------	---

Main menu  
Extra or





**NOTE**

Relay 2 is set the same way as relay 1.

---

### 9.10 Activate daylight saving time

Menu	Button(s)	Device display	Description
Submenu Daylight sav- ing time	<input checked="" type="checkbox"/> Start input mode		Display L1 indicates whether daylight saving time is activated or not. Display L2 shows the month daylight saving time begins. Display L3 shows the month daylight saving time ends. The unit display shows <b>DAYLIGHTSAVING PARAMETER</b> and then <b>DST</b> .
Submenu Daylight sav- ing time  on/off	123 ..... ▶ next digit or ⊗ cancel or = save		Display L1 flashes. Press the <b>123</b> button to activate ( <b>ON</b> ) or deactivate ( <b>OFF</b> ) daylight saving time.

Main menu

Extra



**NOTE**

Use these buttons to switch between the individual displays in input mode (one flashing digit).

Submenu Daylight sav- ing time  on/off Start	123 ..... ▶ next digit or ⊗ cancel or = save		Display L2 flashes. Press the <b>123</b> button to set the month daylight saving time begins. The unit display switches between <b>BEG.</b> and <b>DST</b> .
---	---	--	--

Main menu

Extra



**NOTE**

Use these buttons to switch between the individual displays in input mode (one flashing digit).

Continued

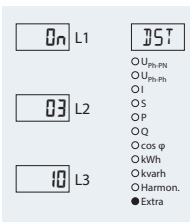
Menu	Button(s)	Device display	Description
Submenu Daylight sav- ing time  on/off End	<b>123</b> ..... ▶ next digit  or ⊗ cancel  or Ⓜ save	 0n L1 JST 03 L2 10 L3 O U <sub>10</sub> ,m O U <sub>10</sub> ,m OI OS OP OQ O Cos φ OKWh OKvarh O Harmon. ● Extra	Display L3 flashes.  Press the V button to set the month daylight saving time ends.  The unit display switched between ENJ and JST.

Main menu

Extra



### 9.11 Language settings

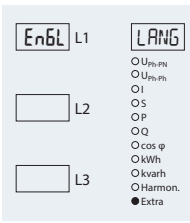
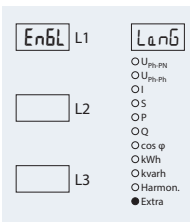





Menu	Button(s)	Device display	Description
Submenu Language	▼ Start input mode	 EnGL L1 LANG L2 L3 O U <sub>10</sub> ,m O U <sub>10</sub> ,m OI OS OP OQ O Cos φ OKWh OKvarh O Harmon. ● Extra	Display L1 flashes.  For German, it displays dEUT For English EnGL  The unit display shows SPRA if the user language is German and LANG if it is English.
Submenu Language set	<b>123</b> .....  or ⊗ cancel  or Ⓜ save	 EnGL L1 LANG L2 L3 O U <sub>10</sub> ,m O U <sub>10</sub> ,m OI OS OP OQ O Cos φ OKWh OKvarh O Harmon. ● Extra	Display L1 shows the user language. Press the <b>123</b> button to select the operating language.  For German, it displays dEUT For English EnGL  The unit display shows SPRA if the user language is German and LANG if it is English.

Main menu

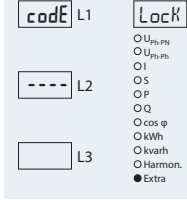
Extra

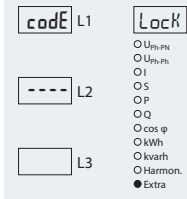

## 9.12 Password

Menu	Button(s)	Device display	Description
Submenu Password	 Start input mode		<p>Display L1 shows CODE.</p> <p>The unit display shows LOCK or FREE.</p> <p>If the device is unlocked, the code number will be displayed in L2. If the device is locked, ---- will be displayed.</p> <p>The device is delivered with the release code 9999, i.e. all functions of the device are available.</p>
Submenu Password set	 .....  next digit or  cancel or  save		<p>Display L1 shows CODE.</p> <p>The unit display shows LOCK or FREE.</p> <p>Display L2 shows 9999. Display L2 flashes.</p> <p>Press the  button to set the number of this segment.</p> <p>Press the  button to switch to the next digit.</p>

Main menu  
Extra



### 9.13 Configuring the pulse output

Menu	Button(s)	Device display	Description
Submenu Pulse output	▼ Start input mode		<p>Display L1 indicates whether the pulse output is deactivated (OFF) or configured for active (P) or reactive (q) energy</p> <p>Display L2 shows the pulse significance, i.e. pulse/kWh or kvarh.</p> <p>Display L3 shows the energy pulse length in ms.</p>
Submenu Pulse output  Set pulse source	123 ..... ▶ next digit or ⊗ cancel or ⏻ save		<p>When you open the menu, the following text is displayed in the unit display: SRC. SOURCE SRC.</p> <p>Display L1 flashes.</p> <p>Press the 123 button to select the active energy (P consumption or P- recovery), the reactive energy (Q consumption or Q- recovery) or deactivate (OFF) the energy pulse.</p>

Main menu  
Extra    ▶ or ▼

   ▶ or ▼

Use these buttons to switch between the individual displays in input mode (one flashing digit).

**NOTE**

Submenu Pulse output  Set pulse significance	123 ..... ▶ next digit or ⊗ cancel or ⏻ save		<p>When you open the menu, the following text is displayed in the unit display: VAL. VALENCY VAL.</p> <p>The first digit in display L2 flashes. Press the 123 button to set the number of this segment.</p> <p>Press the ▶ button to switch to the next digit.</p> <p>If all digits are flashing, you can move the decimal point with the 123 button.</p>
---	---	--	---

Continued

Menu	Button(s)	Device display	Description
Main menu Extra	or		
<b>NOTE</b>	or		Use these buttons to switch between the individual displays in input mode (one flashing digit).
Submenu Pulse output Set pulse length	..... next digit or cancel or save		When you open the menu, the following text is displayed in the unit display: <b>LEN LENGTH LEN</b> The first digit in display L3 flashes. Press the  button to set the number of this segment. Press the  button to switch to the next digit.

Main menu  
Extra or



**NOTE**

If the "Extra" LED flashes after the pulse significance is entered, follow the instructions below. The "Extra" LED flashes until a matching (lower) pulse count or pulse length is entered.

Check the pulse significance in relation to the pulse length. Correct the pulse length or the pulse significance if required.

The maximum processable active or reactive energy can be estimated with the following calculation.

$$\frac{3600 \text{ s}}{2 \times \text{IL} \times \text{pulse/kWh (kvarh)}} = \text{maximum value}$$

**Explanation:**

- 3600 Constant [s]
- IL Required pulse length [s]
- pulse/kWh (kvarh) Required pulse count per kWh or per kvarh [pulse/kWh or pulse/kvarh]
- Maximum value Maximum active or reactive energy output [kWh or kvarh].

### 9.14 Damping coefficient

Menu	Button(s)	Device display	Description
Submenu Damp. coef- ficient	Start input mode		Display L1 shows the damping coefficient used to record the voltage. Display L2 shows the damping coefficient to calculate the current.
Submenu Damp. coef- ficient  Set voltage	..... next digit or cancel or save		When you open the menu, the following text is displayed in the unit display: DF DAMPINGFACTOR DF The first digit in display L1 flashes. Press the  button to set the number of this segment. Range of values: 0 - 8

Main menu  
Extra or

or

Use these buttons to switch between the individual displays in input mode (one flashing digit).

**NOTE**

Submenu Damp. coef- ficient  Set current	..... next digit or cancel or save		The first digit in display L2 flashes. Press the  button to set the number of this segment. Range of values: 0 - 8
---	---	--	---

Main menu  
Extra or

### 9.15 Default settings

Menu	Button(s)	Device display	Description
Submenu Default settings			The unit display shows DEF.
Submenu Default settings  Reset to default settings	Press  +  at the same time		When you press these three buttons at the same time, the following text is shown in the unit display: <b>KILL</b> The device is now reset to its default parameters (default settings) and all stored data are deleted.

Main menu

Extra or next submenu





### 9.16 Zero point creator



Menu	Button(s)	Device display	Description
Submenu Zero point creator	Start input mode		Display L1 shows the state of the zero point creator.
Submenu Zero point creator activate	..... cancel or save		When you open the menu: Display L1 flashes. Press the  button to activate this function. Range of values: 0FF, on

Main menu

Extra or next submenu or

## 10 Reset and delete function

### 10.1 Reset

<p> +  + </p> <p>Only reset the energy meter during setup or if the device is completely reprogrammed</p> <p><b>Caution!</b> Reset will reset all programmed values to the default settings!</p>	<p>To reset, go to the Default settings submenu of the Extra menu.</p> <p>Hold the buttons digit, delete and right arrow at the same time. The 15-segment display will show "KILL" during reset. The device is reset to its default settings, i.e. all stored data are lost!</p> <p>This includes all operating parameters, limits and extreme values as well as the off-delay of the signaling relays. The memory for limit violations is deleted.</p> <p>The settings for time, date and bus address are not affected by a reset.</p> <p>Check all operating parameters for correctness!</p>
--	--

### 10.2 Delete energy meter

#### 10.2.1 Delete energy meter manually

Hold the  button for about 2 seconds to delete the continuous energy meter value currently displayed (active or reactive energy, HT or LT, consumption or recovery).

#### 10.2.2 Delete all energy meters



To delete all energy meters, you can either reset the device or use the optionally available software and KBR Energy Bus.

### 10.3 Deleting extreme values

#### 10.3.1 Deleting individual extreme values

Press the  button for about 2 seconds to delete the extreme values (minimum or maximum values) currently displayed.

### 10.3.2 Deleting all extreme values

To delete all minimum and maximum values, hold the buttons  and  for about 2 seconds while any minimum or maximum value is displayed. The function is also available via the KBR Energy Bus.



## 10.4 Deleting limit settings

### 10.4.1 Deleting individual limit settings

You can only deactivate individual limits in programming mode.

In programming mode, set the type of the limit you want to deactivate to "OFF".

### 10.4.2 Deleting all limit settings

To delete all limits, hold the buttons  and  for about 2 seconds while any limit is displayed. The function is also available via the KBR Energy Bus.

# 11 Memory functions

## 11.1 Device settings

All device settings and configuration data for the memory function are stored in the device.

## 11.2 Basic device parameters

Parameter	Stored by user
Measuring voltage	can be programmed by user in the range from 0001 V to 999.9 kV
Measuring current; transformer primary current	can be programmed by user in the range from 0001 A to 999.9 kA
Measuring current (at the input side, i.e. secondary transformer!)	can be selected by user: 1A or 5A
Pulse output type / pulse significance / pulse length	acc. to user settings
Tariff switching	user can select from digital input, switching via energy bus via Energy Bus or using times programmed in the device, in case of <b>multimes F144-0-LED-EP-...-5</b> only via times programmed in the device.
Synchronization settings	Setting options see measurement period synchronization (only multimes F144-1-LED-ESMS-...-5)
Bus address	acc. to user settings between 0001 and 9999 (only multimes F144-1-LED-ESMS-...-5)
Time	acc. to user settings in hh:mm:ss
Password	according to user settings password is a 4-digit number (leading zeros) 9999 means: Device is not password-protected
Device name	can be defined by the user <sup>1*)</sup> (only multimes F144-1-LED-ESMS-...-5)
Event name	each event is given a unique name <sup>1*)</sup> (only multimes F144-1-LED-ESMS-...-5)
Measurement period	1 / 15 / 30 / 60 min <sup>1*)</sup> (only multimes F144-1-LED-ESMS-...-5)

<sup>1\*)</sup> This function can only be set using a computer with optionally available software (e.g. visual energy).

### 11.3 Long-term memory (only multimes F144-1-LED-ESMS...-5)

The multimes F144-1-LED-ESMS...-5 supports the long-term memory functionality described in the following section.

### 11.4 Load profile memory

The measuring device has a load profile memory that can record a maximum of up to 3840 entries depending on the number of parameters to be stored (active power periods for HT and LT, consumption and recovery, reactive power periods for HT and LT, capacitive and inductive) and the measurement period selected by the user (period values of 60 / 30 / 15 / 1 minute(s) are possible). This means that a period of 15 minutes results in a maximum storage duration of 40 days.

The measurement period and the selection of the parameters to be saved can be parameterized using a computer with the optionally available software.



#### NOTE

#### Setting the internal clock:

If the time of the multimes F144-1-LED-ESMS...-5 is set to less than the duration of one period, the measurement for the instantaneous period is finished and saved the next time the device synchronizes.

If the time of the multimes F144-1-LED-ESMS...-5 is adjusted by more than the period time, the load profile memory is deleted and restarted.

In both cases, a clock adjustment event is created and saved in the event memory. Adjusting the period time:

If the period time is adjusted, the load profile memory is deleted and restarted.

An adjustment event (adjustment of the parameters) is created and entered in the event memory.

### 11.5 Annual energy memory

The daily energy values of the past 365 days for  $W_{\text{Act}}$  consumption,  $W_{\text{React}}$  inductive are stored separately for high and low tariff in an annual energy memory.

## 11.6 Event memory

The event memory saves 4096 events with date, time and status in a ring buffer. The following events are acquired:

Event	Recording
Tariff input	Switchover signal HT => LT with date and time Switchover signal LT => HT with date and time
Sync input	Subsequent synchronization with date and time, information on the synchronization type
Power failures	with date, time and duration of the power failure
Error	Error type with date and time
Changed settings/deletions (powerfail entry)	e.g. reset via EBUS / set clock / deletions / parameter changes leading to deletions
Measuring voltage failures	If the power is reduced to 85 % of the rated voltage for longer than 20 ms (can be set using the computer).



### NOTE

The described memories can only be read or configured via the eBus by means of optionally available software (e.g. visual energy).

## 11.7 Measurement period synchronization

(only multimes F144-1-LRED-ESMS...-5)

The measurement period of the multimes F144-1-LED-ESMS...-5 can be synchronized in four ways, with the measurement period being adjustable. The measurement period and the synchronization always affect all period significance values.

The following 4 types of synchronization are possible:

## 11.8 Synchronization only by internal clock

Synchronization by internal clock is started with the factory reset. From this start time, the clock will synchronize the measurement period every 15 minutes.

**NOTE**

In case of internal synchronization, the measuring period (in the kWh / LT submenu)  (for approx. 2 seconds)!

## 11.9 Synchronization by the energy supplier's synchronous pulse

If the synchronous pulse is available as floating contact from the energy supplier, it can be connected to the synchronization input. If the contact closes for at least 250 ms, it is detected as a synchronous pulse and the measurement period is restarted.

Under certain operating conditions, the energy supplier may carry out a subsequent synchronization while a measurement period is still running. The multimes F144-1-LED-ESMS...-5 ends the running period measurement and saves the period value with a timestamp. The time pattern is shifted to the new start time and a new measurement is started immediately.

### Example:

The period time is set to 15 minutes, i.e. 20 kW input power results in a period value of 20 kW (15-minute period). If there is a subsequent synchronization 3 minutes after the period starts and this 3-minute period is saved, the period value recorded is 4 kW.

If the energy supplier's synchronous pulse is not available, the status message "ext. synchronous pulse missing" is issued and the internal clock continues the time frame.

## 11.10 Synchronization by KBR eBus

Synchronization is carried out via a telex created either by the computer or the bus master and sent to the selected recipients via the KBR ENERGY BUS .

Under certain operating conditions, a subsequent synchronization may be carried out while a measurement period is still running.

The multimes F144-1-LED-ESMS...-5 ends the current period measurement and saves the period value with a timestamp. The time pattern is shifted to the new start time and a new measurement is started immediately.

**Example:**

The period time is set to 15 min

i.e. 20 kW input power results in a period value of 20 kW (15 min period)

If a subsequent synchronization is performed 3 minutes after the period starts and this 3-minute period is saved, the period value recorded is 4 kW.

If the bus synchronous pulse is not available, the status message "ext. synchronous pulse missing" is issued and the internal clock continues the time frame.

## 11.11 Synchronization at tariff change

This type of synchronization makes it possible for the measuring device to change tariffs immediately after the tariff HT/LT has been switched instead of waiting until the end of the measurement period.

The internal clock synchronizes the measurement period. Depending on the configuration by contact at the HT/LT input or by bus signal, this event will also synchronize the measurement period if the tariff is changed. Under certain operating conditions, the synchronization pulse and the internal measurement period synchronization may not be in accordance with the same time pattern. The multimes F144-0-LED-EP...-5 / F144-1-LED-ESMS...-5 ends the current period measurement and saves the period value with a time stamp. The time pattern is shifted to the new start time and a new measurement is started immediately.

**Example:**

The period time is set to 15 minutes, i.e. 20 kW input power results in a period value of 20 kW (15-minute period). If synchronization is performed 3 minutes after the period starts and this 3-minute period is saved, the period value recorded is 4 kW.



## 12 Technical data

### 12.1 Measuring and display values

Wave form for U and I		any
Voltage	RMS value of a measuring interval	Phase - 0: $U_{L1-N}; U_{L2-N}; U_{L3-N}$ / phase - phase: $U_{L1-2}; U_{L2-3}; U_{L3-1}$
	Units	[V, kV] display is switched automatically
	Measuring range	0.00kV to 999.9kV
Current (apparent current)	RMS value of a measuring interval	$I_{L1\ act}; I_{L2\ act}; I_{L3\ act}$ ; instantaneous value for each phase
	Averaging	$I_{L1\ avg}; I_{L2\ avg}; I_{L3\ avg}$ ; floating average value of RMS values over a set period of time
	Units	[A;kA;MA]; display is switched automatically
	Measuring range	0.00A to 999.9kA
Neutral conductor current	RMS value of a measuring interval	$I_{N\ act} / I_{N\ avg}$ instantaneous and average value - see "Phase current"
	Units	[A;kA;MA] display is switched automatically
	Measuring range	0.00A to 1.2 MA
Frequency	Power frequency measurement	$f_{power}$ ; measured with power supply correction
	Units	[Hz]
	Measuring range	40....70 Hz
Apparent power	Calculation	$S_{L1}; S_{L2}; S_{L3}; S_{tot}$
	Units	[VA; kVA; MVA] display is switched automatically
	Measuring range	0.00 VA to 999 MVA
Active power	Calculation	$P_{L1}; P_{L2}; P_{L3}; P_{total}$
	Units	[W; kW; MW] display is switched automatically
	Measuring range	0.00W to 999MW
Reactive power	Calculation → ind. and cap.	$Q_{L1}; Q_{L2}; Q_{L3}; Q_{total}$ ; distinction between ind./cap.
	Units	[Var; kvar; Mvar]; display is switched automatically.
	Measuring range	0.00 Var to 999 MVar
Power factor	Calculation → ind. and cap.	$\cos_{\phi L1}; \cos_{\phi L2}; \cos_{\phi L3}; PF_{L1}; PF_{L2}; PF_{L3}; PF_{Tot}$ ; distinction between ind./cap. $\cos_{\phi}$ in the display
	Measuring range	CosPhi 0.1ind. ← 1 → 0 1cap., PF 0.1 - 1

Continued

Active energy	Calculation	$W$ (HT/LT); $P_{\text{average max. of a measurement period}}$
	Units	[Wh; kWh; MWh]; display is switched automatically
	Measuring range	0.0kWh to 999999999.9kWh
Reactive energy	Calculation	$W_{\text{React}}$ (HT/LT) → ind. or cap. $Q_{\text{average max. of a measurement period}}$
	Units	[varh; kvarh; Mvarh]; display is switched automatically
	Measuring range	0.0kvarh to 999999999.9kvarh
Harmonics	Distortion factor (THD) for voltage	Voltage: DF-UL1; DF-UL2; DF-UL3,
	Partial distortion factors	3rd; 5th; 7th; 9th; 11th; 13th; 15th; 17th and 19th Harmonics of the voltage
	Units	[%]
	Measuring range	0.00% to 100%
Current harmonics <small>(only multimes F144-1-LED-ESMS...-5)</small>	Current harmonics	3rd; 5th; 7th; 9th; 11th; 13th; 15th; 17th and 19th Harmonic for each phase of current: $I_{\text{TotL1}}$ ; $I_{\text{TotL2}}$ ; $I_{\text{TotL3}}$ for each phase separately
	Current harmonics total	
	Units	[A]
	Measuring range	0.00A to 999.9kA

## 12.2 Measurement accuracy

Current	$\pm 0.5 \% / \pm 1$ digit
Voltage	$\pm 0.5 \% / \pm 1$ digit
Apparent power	$\pm 1 \% / \pm 1$ digit
Active power	$\pm 1 \% / \pm 1$ digit
Reactive power	$\pm 1 \% / \pm 1$ digit
Power factor	$\pm 1 \% / \pm 1$ digit
Frequency	$\pm 0.1 \text{ Hz} / \pm 1$ digit

### 12.3 Measuring principle

Sampling	128 readings per period
A/D converter	10 bit
Measurement of U and I	Simultaneous recording of U and I readings;
Update speed (complete measuring cycle)	~ 330 ms
Harmonics calculation	DFT with 128 points over one period
Frequency measurement	Consumption: Voltage measured between phases L1, L2, L3 - N; correct frequency measurement with power supply correction

### 12.4 Device memory

Main and data memory	2 MB RAM battery-buffered
Program and parameter memory	256 kB flash
Memory type	Ring buffer
Long-term memory (1 year) (only F144-1-LED-ESMS...-5)	Daily values for active and reactive energy (HT and LT) for consumption and recovery
Long-term memory for 160 / 80 / 40 days / 64 hours (only F144-1-LED-ESMS...-5)	60 / 30 / 15 / 1 minute – average values of: $P_{total}$ ; $Q_{total}$
Extreme values (max./min.)	Extreme values that occurred after connecting the unit to the power supply or after the extreme value memory was deleted manually (maximum indicator function) including date and time
<b>Event memory:</b>	Memory size
	4096 events including date and time they occurred
Limit violation	Time for acquisition
	≥ 550 ms
Measuring voltage dips	Time for acquisition
	≥ 20 ms; threshold can be set using the computer, value after reset 85 % of rated voltage (in accordance with EN 61000-4-30).
Measuring voltage	approx. 5 years acc. to manufacturer's specifications

### 12.5 Power supply

Power supply	US1: ≈ 110 - 240V ±10 % DC/50/60 Hz
Power consumption <15 VA, 10 W	US5: ≈ 22.5 - 64 V ±10 % DC/50/60 Hz

## 12.6 Hardware inputs and outputs

### 12.6.1 Inputs

Voltage measurement inputs	$U_{L1-L2}; U_{L2-L3}; U_{L3-L1}$	3 x 5 V...100 V...120 V AC (measuring range 1) 3 x 20 V...500 V...600 V AC (measuring range 2)
	Input impedance	1.2 MOHM (Ph-Ph)
	Measuring range	can be configured using voltage and current transformers
Current measurement inputs	IL1; IL2; IL3	3 x 0.01 A...1 A...1.2 A AC (measuring range 1) 3 x 0.05 A...5 A...6 A AC (measuring range 2)
	Power consumption	≤ 0.3 VA per input at 6 A
	Measuring range	can be configured using voltage and current transformers
Digital inputs	Tariff input (only F144-1-LED-ESMS...-5)	Digital input for floating contact, HT/LT switching, signal e.g. from energy supplier, contact open => HT, contact closed => LT
	Synchronous input (only F144-1-LED-ESMS...-5)	Digital input for floating contact Measurement period synchronization; pulse length ≥ 250 ms
	Power supply	27 V / 15 mA DC internal

### 12.6.2 Outputs

Signaling relay for limit violations	Number	2
	Contact	floating, open in case of limit violation
	Reaction speed	programmable, max. 255 sec.
	Switching capacity	max. 250 V (AC) / 2 A floating - not safe to touch; the same phase must be applied to both relays
Pulse output	Output type	proportional to active or reactive energy, configurable on the device from min. 0.001 to max. 9990 pulse(s) per kWh
	Optocoupler output	15 mA at max. 35 V; S0 interface
	Accuracy class	2
	Pulse length	configurable, min. 30 ms, max. 999 ms
	Power supply	external

Continued

Serial interface multimess F144-0-EP-...-5	RS 485 interface	For device configuration via computer and optional software.
	Baud rate	38400 fixed
	Addressing	Adresse 1 fixed
Serial interface multimess F144-1-ESMS...-5	BUS	RS485 for connection to the eBus; max. 32 devices, up to 1000 devices with bus amplifier
	Baud rate	38400
	Addressing	Can be addressed up to address 9999; automatically via software or manually

## 12.7 Electrical connection

Connection elements		Plug terminals
Permissible cross section of the connection lines		2.5 mm <sup>2</sup>
Measuring voltage inputs	Fuse protection	max. 1 A slow-blow max. C2 automatic isolating switch UL/IEC-approved
Measuring current inputs	Fuse protection	NONE!!! Always short-circuit current transformer terminals k and l before opening the circuit!
Input control voltage	Fuse protection	max. 1 A slow-blow max. C2 automatic isolating switch UL/IEC-approved
Relay output	Fuse protection	max 2A medium time-lag
BUS connection	Connection material	To ensure proper operation, only use shielded twisted-pair cables; e.g. I-Y-St-Y2x2x0.8 EIB
Pulse output	Connection and cables	Ensure correct polarity! To ensure proper operation, only use shielded twisted-pair cables; e.g. I-Y-St-Y2x2x0.8 EIB

Continued

Transformer connection	Connections	See wiring diagram
Interface connection	RS485 BUS connector pins	Terminal 90 (L) → Pin L Terminal 91 (A) → Pin A Terminal 92 (B) → Pin B

## 12.8 Mechanical data

Switchboard installation	Housing dimensions	144 x 144 x 60 mm (H x W x D)
	Installation cut-out	138 x 138 mm
	Weight	750 g

## 12.9 Ambient conditions, electrical safety and standards

Ambient conditions	Standards	DIN EN 60721-3-3:1995-09 + DIN EN 60721-3-3/A2:1997-07; 3K5+3Z11; (IEC721-3-3;3K5+3Z11)	
	Operating temperature	K55 (-5 °C .... +55 °C)	
	Humidity	5% - 95% non-condensing	
	Storage temperature	K55 (-25 °C .... +70 °C)	
	Operating altitude	0 to 2000 m above sea level	
Electrical safety	Standards	DIN EN 61010-1:2011-07; DIN EN 61010-2-030:2011-07	
	Protection class	I	
	Overtoltage category, measurement category	Voltage measurement: Current measurement: Power supply:	CAT III: 300 V; CAT II: 400 V CAT III: 300 V CAT III: 300 V
	Rated surge voltage	4kV	
Protection type	Standards	DIN EN 60529:2014-09	
	Front	IP 40, with housing seal IP 51	
	Terminals	IP 20	
EMC	Standards	DIN EN 61000-6-2:2006-03 + amendment 1:2011-03 DIN EN 61000-6-3:2011-09 + amendment 1:2012-11 DIN EN 61326-1:2013-07	
Synchronization	Type	internal, manual, tariff switching or by KBR eBus	
Synchronization time	Adjustable	manually once per measurement period if internal synchronization is selected on the device.	

## 12.10 Default settings after reset

Primary voltage / secondary voltage	400 V
Primary current / Secondary current	5 A
Measurement period time	15Min. Measurement period
Daylight saving time	from months 03 to 10
Low tariff time	Umschaltung über hardware am Gerät aktiviert multimes 4F96-0-EP-...-5 über interne Uhr
	Programmed time for internal switching between HT and LT: int. 00.00 to 00.00 (no low tariff time activated)
Language	deut. (German text display)
Damping coefficient for current and voltage	DF 0 (no damping)
Energy pulse	P. (active power for consumption), 1 pulse /kWh, pulse length 100 ms
Alarm relay	ON-delay tON = 0 sec OFF-delay tOFF = 0 sec
Analog output	Deactivated
Measurement period synchronization	Energy bus
Password	9999 / all functions can be accessed
Period entries in the load profile memory	3480 entries

### Unaffected by a RESET:

1. Bus address

2. Time



## 13 Serial interface

### 13.1 RS 485 port operation (only multimess F144-0-LED-EP-...-5)

The RS485 port of the multimess 4F144-0-LED-EP-... is designed for conveniently configuring the instrument. Connection to the computer is performed via interface converter eBus-232-485. The device can be configured by means of optionally available software.

### 13.2 RS 485 bus operation (only multimess F144-1-LED-ESMS-...5)

The RS485 port of the multimess F144-1-LED-ESMS-... -4 is designed for operation at the KBR eBus. You can operate one or several multimess F144-1-LED-ESMS-...-5 devices together with the ENERGY BUS across great distances. The bus is connected to the computer via the interface converter eBus-232-485 or the MULTIMASTER. With the corresponding Windows® Software, all bus devices can be parameterized and visualized. On demand, we will be glad to provide information on which other devices you can connect to the eBus and on the functions of our Windows® software.

Information on the structure and the technical parameters of the eBus can be found in our installation guide for the KBR eBus. Just send a request for this installation guide.

## 14 Overvoltage and lightning protection

To protect your purchased high-quality devices from damage, we strongly recommend that you take overvoltage protection measures. Protect control voltage inputs, pulse and bus lines.

## 15 Troubleshooting

### No function.

Check the power supply, back-up fuse, isolating switch and supply line.

### The measuring voltage of a phase is 0V.

Check the back-up fuse and isolating switch of the phase.

### A phase of the current display has a different sign.

Check k and l of current measurement and correct if necessary.

### Compared to the measurement of the energy supplier, the measured values for energy and power are too small.

Check k and l of the current measurement as well as if the phases of the transformers are correct and adjust if required.

### One of the 8 LEDs is flashing.

There has been a limit violation in the menu that corresponds to the flashing LED.

**ErrU OVERLOAD or ErrI OVERLOAD.**

**ErrU:** Voltage input of the measuring amplifier overloaded  
Switch off measuring voltage and check set transformer ratio. In case of direct measurement, the programmed secondary voltage value must correspond to the mains voltage.

Note: The device selects the measuring range depending on the secondary voltage configured. The **multimes F144-0-LED-EP...-5 / F144-1-LED-ESMS...-5** operates in measuring range 1 as long as the configured secondary voltage value does not exceed 110 V. If it does, **multimes F144-0-LED-EP...-5 / F144-1-LED-ESMS...-5** operates in measuring range 2.

**ErrI:** Current input of the measuring amplifier overloaded  
Adjust programming and select larger measuring range. Alternatively, switch off the measuring current and check the transformer ratio.

Note: The device selects the measuring range depending on the secondary current that was set, i.e. either measuring range 1 at 1 A or measuring range 2 at 5 A.

# 16 Appendix

## 16.1 Added functionality: Profibus

The multimes F144-1-LED-ESMS...-5 is now also available with the Profibus option (new name multimes F144-1-LED-ESMSDP...-5).







The additional functions are described in this appendix (Configuring Profibus)

## 16.2 Setting the bus protocol

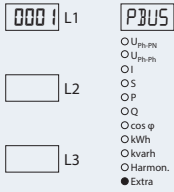
Menu	Button(s)	Device display	Description
Main menu Extra			
Submenu Profibus	Start input mode		Display L1 shows the device address. The baud rate is displayed in display L2. The unit display shows the current bus protocol.
Submenu Profibus Assign address	Start input mode		The first digit in display L1 flashes. Press the  button to enter the input mode and set the bus protocol
Submenu Profibus Assign bus protocol	..... Start input mode cancel or save		Display L1 shows the device address. The baud rate is displayed in display L2. The unit display flashes. You can choose from different bus protocols by pressing the  button. (eBus or Modbus) If the device is equipped with the Profibus option, the Profibus protocol is also available for selection.

Main menu  
Extra save

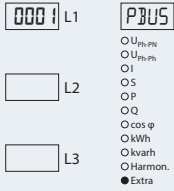
### 16.3 Set Profi bus bus address

Menu	Button(s)	Device display	Description
Main menu Extra			
Submenu Profi bus	 Start input mode		Display L1 shows the device address.
Submenu Profibus  Assign address	 next digit or  cancel or  save		<p>The first digit in display L1 is flashing.</p> <p>Press the button  to set the value of this digit.</p> <p>Press the button  to switch to the next digit.</p>

Main menu-  
Extra



#### NOTE

When the Profi bus setting is selected, no baud rate is set up!  
The device automatically detects the required baud rate.

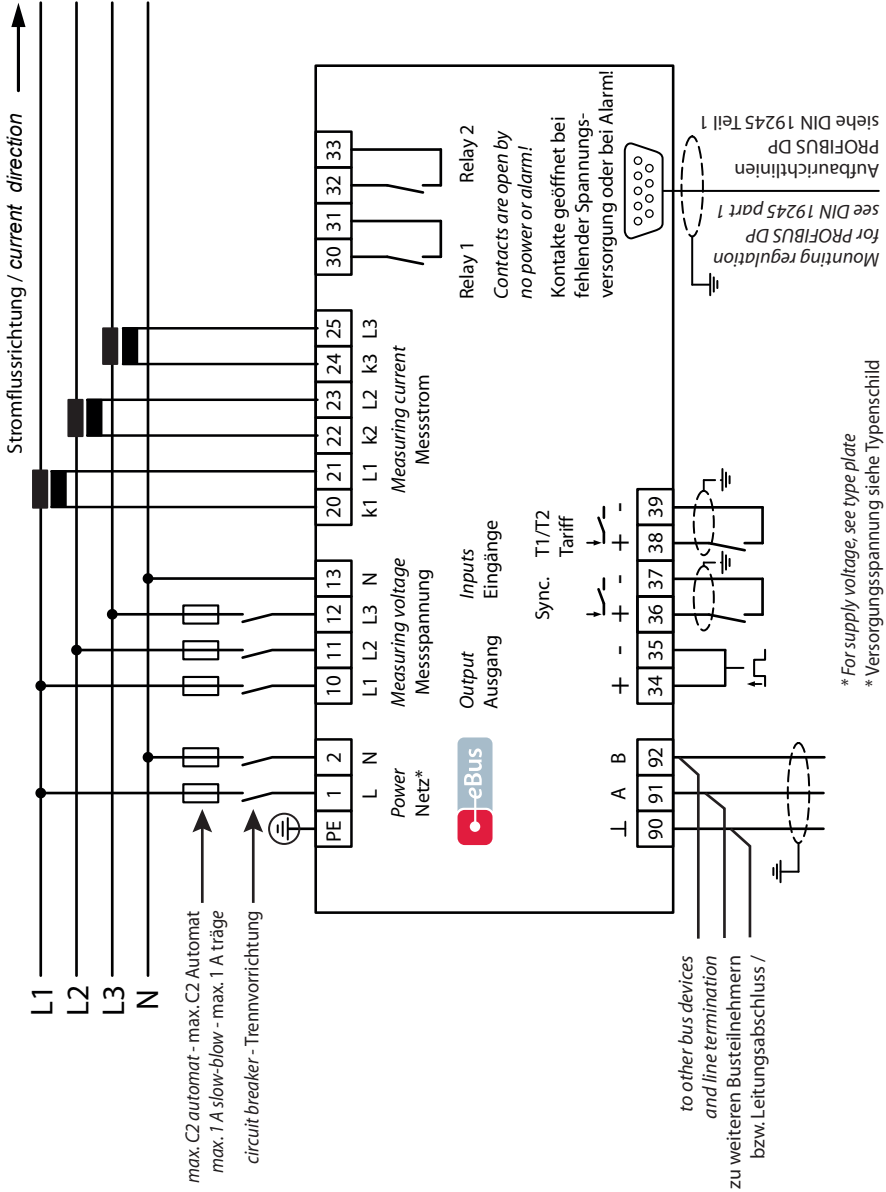



**KBR Kompensationsanlagenbau GmbH**

Am Kieferschlag 7  
D-91126 Schwabach,  
Germany

P +49 (0) 9122 6373-0  
F +49 (0) 9122 6373-83  
E [info@kbr.de](mailto:info@kbr.de)

[www.kbr.de](http://www.kbr.de)