



User manual Technical parameters

multimax

Load management system

4D6



**Your partner for
network analysis**

© KBR Kompensationsanlagenbau GmbH
Misprints and printing errors
as well as technical changes reserved.

Table of Contents

1	Introduction	5	4.1	Device memory, battery-buffered	16
1.1	User manual	5	4.1.1	Inserting or replacing the backup battery	16
1.2	Intended use	5	4.2	Device installation	17
1.3	Explanation of safety relevant symbols	6	4.3	Connections	17
1.4	Safety notes	7			
1.5	Product liability	7	5	Control and display panel	19
1.6	Disposal	8	5.1	Description of buttons and dis- plays,default settings, setting ranges	19
2	Range of functions	9			
2.1	Monitoring energy consumption..	9	6	Error message overview:	26
2.2	Energy optimization with trend calculation	9	7	Overview of system parameters..	28
2.3	Switching devices on or off using compensation power	9	8	Description of parameters	29
2.4	Switching devices off via relay outputs.....	10	8.0.1	General parameters.....	29
2.4.1	Device regulation via analog output module multisio 1D2-2AO.....	10			
2.4.2	Digital output	10	9	Line parameters	37
2.4.3	Decentralization using substations	10	9.1	Meter inputs.....	47
2.5	Recording states using message modules	11	9.2	Module management.....	48
2.6	Power measurement using energy pulses from the energy supplier..	12	9.3	I/O parameters	48
2.7	Meter pulse monitoring.....	12	9.4	Timer programs	50
2.8	Recording current power	12	9.5	Measured value output.....	54
2.9	Measuring-period synchronization using an energy supplier pulse....	13	9.6	Time/date.....	55
2.10	Three target values for consumption limits	13	9.7	Bus parameters	55
2.11	Error messages.....	14	9.8	Display parameters.....	56
2.12	Long-term memory.....	14	9.9	Error message parameters.....	57
3	Device overview	15	9.10	Password/reset.....	57
4	Installation	16	10	Description of display items.....	59
			10.1	P current	59
			10.2	Potential	60
			10.3	Line data.....	62
			10.4	I/O state	63
			10.5	Tracked Ptarg.....	64
			10.6	Meter values.....	65
			10.7	Current error messages.....	69

11	Technical data multimax 4D6.....	70	12.2	Relay output module connection diagram.....	77
11.1	General technical data for additional modules.....	70	12.3	Relay output module LED display.....	78
11.2	Technical data for multimax 4D6 basic module.....	71	12.4	Function of the scan button.....	78
11.2.1	Operating and display elements.....	71	12.5	Function of the DIP switches.....	79
11.2.2	Device memory.....	71	12.6	DIP switch settings.....	80
11.2.3	Power supply.....	72	12.7	Function description of the digital input module multisio 2D2-4DI.....	80
11.2.4	Hardware inputs.....	72	12.8	Digital input module connection diagram.....	81
11.2.5	Electrical connection.....	72	12.9	Digital input module LED display.....	81
11.2.6	Hardware outputs.....	73	12.10	Function of the scan button.....	82
11.2.7	Mechanical data and dimensioned drawing of the basic module.....	73	12.11	Function of the DIP switches.....	82
11.2.8	Environmental conditions / electrical safety.....	74	12.11	DIP switch settings.....	83
11.2.9	Mechanical data and dimensioned drawing for multimax 4F96-DS display.....	75	12.12	Function description of measuring module multimess 1D4.....	84
11.2.10	Serial interface.....	76	12.13	Function description of analog input module multisio 2D2-4AI	86
11.2.11	Protective measures – overvoltage and lightning protection.....	76	12.14	Function description of analog output module multisio 1D2-2AO.....	88
12	Connecting additional modules..	77	12.15	Function description of digital output module multisio 2D2-4DO	91
12.1	Function description of the relay output module multisio 1D4-4RO ISO	77			

1 Introduction

Thank you for choosing this **KBR quality** product.

To familiarize yourself with device operation and configuration, we recommend you read this manual carefully. This will enable you to make use of the entire range of functions that this high-quality product offers.

The individual chapters serve to explain the technical details of the device and show how to properly install and start up the device to prevent damage.

1.1 User manual

This user manual is included in the scope of delivery of the device and must be accessible to the user at all times (e.g. in the switchgear cabinet). Even if the device is resold to third parties, the manual remains an inherent part of the device.

Although the utmost of care has been taken in putting together this user manual, errors may still occur. We would be very grateful if you could notify us of any errors or unclear descriptions you may notice.

1.2 Intended use

This device helps you to optimize energy consumption and avoid expensive load peaks.

The system assists you in monitoring the energy consumption of your devices, helps you to make optimum use of your tariff and permanently lower your energy costs.

This device does not, however, render careful system planning indispensable. Moreover, it is essential that you take time to configure the device in line with your system parameters on first use and plan the shut-down of your devices.

1.3 Explanation of safety relevant symbols

These operating instructions contain notes that must be observed for your personal safety and to avoid damage to equipment. These notes are identified by a warning sign or information symbol, depending on the degree of hazard they represent.



Warning

"Warning" means that death, major injuries or damage may occur if suitable safety precautions are not taken.



Caution

"Caution" means that minor injuries or damage may occur if suitable safety precautions are not taken.



Note

"Note" is an important piece of information on the product, its operation or the respective part of the operating instructions to which special reference is being made.

Disclaimer

The contents of these operating instructions have been carefully reviewed in terms of the hardware and software described. Nonetheless, deviations cannot be ruled out, and the manufacturer cannot guarantee 100% conformity. The specifications made in these operating instructions are reviewed on a regular basis; any corrections required will be included in the next revision.

1.4 Safety notes

In order to prevent operating errors, device operation is kept as simple as possible. This will enable you to start your device up quickly.

In your own interest, however, the following safety notes should be read carefully. The applicable DIN / VDE regulations must be observed for installation!

Power supply connection, setup and operation of the device must be performed by qualified personnel only. Qualified personnel as defined in the safety notes in this user manual are those authorized to set up, ground and mark devices, systems and circuits in accordance with applicable standards and regulations.

To prevent fire and electric shocks, the device must not be exposed to rain or humidity!

Before connecting the device to the power supply, check whether the local power supply conditions comply with the specifications on the device name-plate.



Caution

A faulty connection can lead to the destruction of the device!

For device connection, the data given in the connection chart must be complied with (see "Connection chart") and there must be no voltage in the connection lines. When wiring, always ensure that all wiring material used is neither damaged nor defective and that the polarity is correct!

In order to ensure proper and safe product operation, it must be transported, stored, installed and assembled in accordance with the specifications, as well as carefully operated and maintained.

A visibly damaged device must generally be considered unfit for use and disconnected from the power supply!

Error detection, repair and maintenance work may only be carried out in our facilities or after contacting our service team. Opening the device unauthorized shall render your warranty null and void. Correct operation can no longer be guaranteed!

Opening the device may expose live parts. Capacitors in the device may still be under load, even if the device has been disconnected from all voltage sources. Open devices must not be operated!

Systems that are at risk from lightning strikes must feature lightning protection for all input and output lines!

1.5 Product liability

You have purchased a high-quality product. Only components of the highest quality and maximum reliability are used.

Each device is subject to long-term testing before it is delivered.

For details on product liability, please refer to our general terms and conditions for electronic equipment, which you can find at www.kbr.de.

Warranty device properties apply only if the device has been operated in accordance with its intended use!

1.6 Disposal

Defective, outdated or disused devices must be properly disposed of.

If required, we are happy to dispose of the devices for you.

2 Range of functions

The **multimax 4D6** energy control system can significantly contribute to lowering commercial energy costs.

2.1 Monitoring energy consumption

The peak power is an important cost factor for special tariff devices.

The **multimax 4D6** ensures optimum distribution of available power and helps prevent expensive power peaks by means of intelligent monitoring of energy consumption.

2.2 Energy optimization with trend calculation

The **multimax 4D6** works as an optimization calculator, taking into account the assumed further energy consumption within the measurement period. To avoid unnecessary shutdown, careful adjustments are made to the energy consumption in consideration of the device properties:

2.3 Switching devices on or off using compensation power

Negative compensation power switches devices off and positive compensation power switches them on. Compensation power is the result from the comparison of the trend power with the rated power taking into account the available consumer power.

2.4 Switching devices off via relay outputs

The basic module features 5 non-floating relay contacts to switch off the devices participating in optimization.

Using 4-stage additional components, up to 32 switching outputs can be implemented (see “Connecting additional modules”).

NO or NC contact functions can be programmed to switch off the devices.

2.4.1 Device regulation via analog output module multisio 1D2-2AO

For devices that can be regulated continuously via an analog input (0–10 V/0–20 mA), there is an analog output module available.

This ensures that power consumption is fully and continuously exploited (the trend power always corresponds to the target period value).

2.4.2 Digital output

The basic module of the multimax load management system features a digital output (I/O – parameter M00.12, please ensure correct polarity) with a freely assignable output address. This means that devices which feature a digital input (S_0 compatible) can be controlled directly. Furthermore, the current state of a device can be visualized, e.g. by connecting a digital output to a BMS.

By assigning a digital output to the prewarning contact (O 48), its status can be established, e.g. through a control light with a digital control input.

Using the **additional module multisio-4DO**, this functionality can be extended by four digital outputs.

2.4.3 Decentralization using substations

The multimax energy control system and its central system can be expanded using substations. Communication is carried out via a bus line.

2.5 Recording states using message modules

By determining the state of the devices that can be optimized, the optimization action can be controlled. A message input can be associated to every output.

In addition to the digital input module inputs (for floating switches or electronic switches (ensure correct polarity)), the voltage inputs of the multimes 1D4 measuring module can also be used as message inputs. This module enables 230 VAC feedback (e.g. directly from the device main switch) to be evaluated, where by an input voltage of > 70 VAC is evaluated as an on state.

The multimax 4 load management system receives important information about each device via the message inputs. In this way, it can be established whether

- the device is reported as optimizable via the input
- the device is reported as inactive

The following are also possible:

- External device control (permanently switched on (Manual_On) or permanently switched off (Manual_Off))
- Changing line priority

In the case of running timer programs, there is an additional option to modify the process and influence the state of the optimization lines:

- Emergency_On (switches on the line in case of emergency)
- Emergency_Off (switches off the line in case of emergency)
- Starting a generator (utility station)
- Default as contact (when active)

The contact switches, for example when the compensation power is negative, if there is no longer any line to switch off and the trend power is greater than the target value.

The hysteresis for switching back is fixed at 10 seconds; there is no hysteresis for switching on.

The maximum prewarning contact is activated through the assignment of the virtual output A48 to a relay output.

2.6 Power measurement using energy pulses from the energy supplier

The multimax can be adapted to the energy supplier conditions. Energy proportional energy pulses are required as characteristic quantity for the power. They are either provided by the network operator or created by a pulse generator/counter. The instantaneous power for trend calculation is continuously determined via pulse period measurement and pulse count.

2.7 Meter pulse monitoring

In case the pulses are interrupted, a central error message system can be activated by means of the error message contacts.

2.8 Recording current power

If the energy supplier cannot provide an energy pulse, current system power can be recorded by conducting a current and voltage measurement on the supply using the multimes 1D4:

The multimes 1D4 measuring module has three measuring channels whose measured values can be further processed directly as power values. The fourth channel relays the total value of the three measuring channels. This means that four power values are provided.

I/O parameters of channels 1 to 4:

Channels 1, 2 and 3 (single channel):

- Channel name
- Primary transformer voltage value
- Secondary transformer voltage value
- Primary transformer current
- Secondary transformer current
- Measurement type: consumption or recovery
- Single or three-phase power measurement

Channel 4 (mixed channel):

- Channel name
- Primary transformer voltage value (taken from channels 1 to 3)
- Secondary transformer voltage value (taken from channels 1 to 3)
- Primary transformer current value (taken from channels 1 to 3)
- Secondary transformer current value (taken from channels 1 to 3)
- Measurement type: consumption or recovery

Channels 1, 2 and 3 (single channel):

If set to single phase, only the measured value of this channel will be relayed as current power.

If set to three-phase, the measured value of the channel is extrapolated to a three-phase measurement and relayed as the total current power. The output value of channel 4 would then correspond to the sum of three three-phase measurements.

For three-phase measurements, either measuring channels 1, 2 and 3 can be used as three different meter inputs or channel 4 can be used exclusively as a single mixed channel.

However, the measuring mode of each individual channel must be set to single phase.

Meter pulse monitoring

Meter pulse monitoring can only be used to monitor digital inputs. The multimes 1D4 provides an analog measured value.

2.9 Measuring-period synchronization using an energy supplier pulse

A measuring period synchronous pulse provides for synchronicity of the measuring periods from energy supplier and energy control system. This pulse is generally provided by the network operator. If there is no synchronous pulse, the device will generate the measuring period time itself. In the overall system, synchronization is generally performed by the eBus master.

2.10 Three target values for consumption limits

3 individually programmable rated values for power are available. Switching between the rated values is realized by means of floating contacts (e.g. by the energy supplier). The switching of target values can either be performed using internal timer programs or a target value list.

2.11 Error messages

If an error occurs, an error message is displayed.

Emergency shut-down E17 $P_{cum} > P_{targ}$

Emergency shut-down E18 max. Pact limit violated

Emergency shut-down E22 meter pulse 1 failure

Emergency shut-down E23 meter pulse 2 failure

Emergency shut-down E24 meter pulse 3 failure

Emergency shut-down E25 meter pulse 4 failure

Emergency shut-down E26 meter pulse 5 failure

After the error is removed, the message is automatically reset.

2.12 Long-term memory

The energy control system disposes of a battery buffered long term memory.

- Measuring period values for 40 days at 15 min. measuring intervals
- Continuous energy meter for high and low tariffs
- 2,450 switching operations
- 4,096 event memory entries
- 512 operation logbook entries
- 512 timer program entries

3 Device overview

From left to right, you can see:

- The display and its function keys
- The multimax 4D6 basic module
- The multisio relay module
- The multisio digital input module



4 Installation

In this chapter, you will find a description of:

- "Device memory, battery-buffered"
- "Mounting the device"
- "Connections"

4.1 Device memory, battery-buffered

The device is equipped with an internal data memory which is battery buffered to preserve long-term data. To prevent it from being discharged, this backup battery (e.g. Varta CR 2032) is not built in when the device is delivered, but included in the delivery separately packaged.



Caution

Before the initial start-up of the device, please insert the backup battery first (as described in the following), as otherwise any stored data would be lost in the event of power failure.

4.1.1 Inserting or replacing the backup battery

1. Disconnect the device from the power supply.
2. Lift the upper housing cover using a suitable tool (e.g. a small screwdriver).
3. When replacing a battery, remove the empty battery from the clamping bracket using the tool.
4. Push the new battery into the clamping bracket and make sure that it is inserted correctly and has the right polarity.
5. Replace the upper housing cover and click it back into place.
6. Reconnect the device to the supply voltage.

**Caution**

When the battery is empty or has been removed, there is no supply voltage. In this case, not only the storage data are lost, but the time settings have to be reset as well!

4.2 Device installation

The applicable DIN / VDE regulations must be observed for installation!

Before the device is connected to the power supply, check whether the local power supply conditions comply with the specifications on the nameplate. A faulty connection may destroy the system!

The device must be connected in accordance with the connection diagram. For energy and synchronous pulse input, polarity must be observed (contact your energy supplier).

Systems that are at risk from lightning strikes must feature lightning protection for the control voltage, bus line and pulse lines (e.g. energy supplier pulse lines from the transformer station to the location of the energy control system).

4.3 Connections**Caution**

To keep interfering pulses away from the inputs, a shielded cable must be used for the energy and synchronous pulse supply, and for the connection to the PC (e.g. J-2Y(St) Y 2x2x0.8 mm). (Shielding may only be connected to PE in the vicinity of the main unit).

**Terminals
1 (L) / 2 (N)
and PE**

Power supply connection. Auxiliary voltage is required for device operation. For technical data, please refer to the nameplate.

**Terminals
90 (earth),
91 (A) and
92 (B)**

Interface connection for communication at the energy bus

Terminal 40 (C)	Supply voltage connection to the relay output terminals 41 to 45 The relays for the control outputs share the same connection to the supply voltage.
Terminals 41 (k1) to 45 (k5)	Non-floating relay contacts These contacts serve as control outputs. The contacts are open if the device is disconnected and when stages are not switched on. Maximum switching capacity 2A at 250V AC.
Terminal 30 (C)	Supply voltage connection to the relay output terminal 31 (k6)
Terminal 31 (k6)	Floating relay contact. This contact serves as a message or alarm output. During operation, an audible or visual message may be activated or a consumer switched off. The contact is open as long as the device is dead as well as when there is an active message. Maximum switching capacity 2A at 250V AC.
Terminals 80 and 81	Digital output
Terminals 50 to 59	Digital inputs, e.g. for pulse counter

Connection diagram

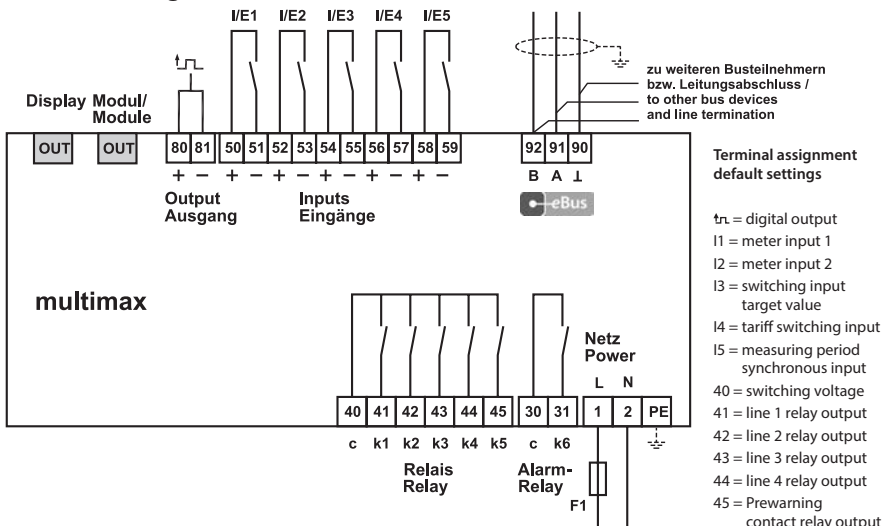

EDEBDA0220-3714-1_EN

5 Control and display panel

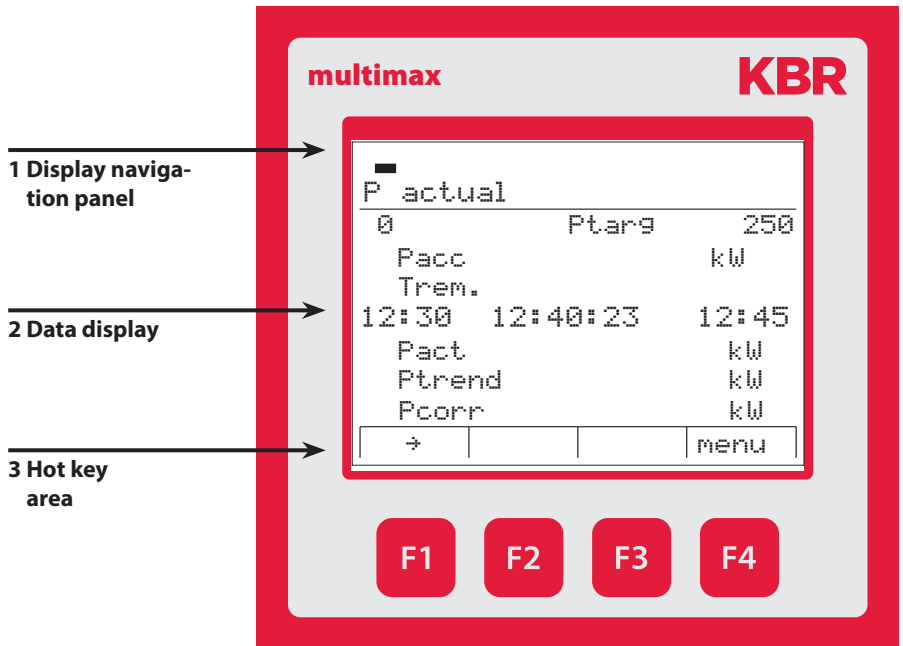

5.1 Description of buttons and displays, default settings, setting ranges

1 Display navigation panel

The navigation panel shows the main menu selected, considerably simplifying device operation.

The operator can immediately see what menu he is in.

2 Unit display

The DOT matrix display is normally used to show measured values.

In some submenus, this display area is used to show additional information to assist operation.

3 Hot key area

The text line corresponds to the function keys below it and is used to issue messages and text. The interaction between key and corresponding display ensures user-friendly and self-explanatory operation.

I/O parameters		Basic module	Function	
Inputs	I 01	Pulse counter		Terminals 50 and 51
	I 02	Pulse counter		Terminals 52 and 53
	I 03	Setpoint switching input	NO contact	Terminals 54 and 55
	I 04	Tariff switching input	NO contact	Terminals 56 and 57
	I 05	Measuring interval synchronous input	NO contact	Terminals 58 and 59
Outputs	O 01	Relay output		Terminals 40 and 41
	O 02	Relay output		Terminals 40 and 42
	O 03	Relay output		Terminals 40 and 43
	O 04	Relay output		Terminals 40 and 44
O 48	Early-warning contact relay output	NO contact		Terminals 40 and 45
O 49	Alarm relay	NC contact, dead and open in the event of errors		Terminals 30 and 31
O 50	Digital output	Digital output		Terminals 80 and 81
Module number Input number	M00.1	Pulse counter E 01	inverse	no
			t Pact => 0	0 sec.
			Pulse value	1 p/kWh
			U primary	1V
			U secondary	1V
			I primary	1A
I secondary	1A			

Module number Input number	M00.2	Pulse counter I 02	inverse	no
			t Pact => 0	0 sec.
			Pulse value	1 p./kWh
			U primary	1V
			U secondary	1V
			I primary	1A
			I secondary	1A
			I 03	not inverse
			I 04	not inverse, HT, if active = LT
			I 05	not inverse
			O 01	not inverse, relay group 0
			O 02	not inverse, relay group 0
O 03	not inverse, relay group 0			
O 04	not inverse, relay group 0			
O 48	not inverse, relay group 0			
O 49	inverse			
O 50	not inverse, relay group 0			
Module number Output number	M00.3	Digital setpoint switching input		
		M00.4	Tariff switching input	
		M00.5	Synchronous input	
		M00.6	Relay output	
		M00.7	Relay output	
		M00.8	Relay output	
		M00.9	Relay output	
		M00.10	Early-warning contact relay output	
		M00.11	Alarm relay	
		M00.12	Digital output	

Parameters		Setting ranges
General parameters 1	TYPE	value, switching input, target value list
	Target value 1	0 to 50000 kW
	Degree of optimization	80% to 100%
	period duration	1, 10, 15, 30 or 60 minutes
	Switching interval	2 to 30 seconds
	Synchronization	Input, internal, bus, tariff
General parameters 2	Minimum monitoring	yes, no
	Pact monitoring	yes, no
	Target value tracking	Off, month, year
	Target value tracking	0% to 100%
	Externally-determined compensation value	yes, no
	Energy type	0 to 99
	Unit	kW, MW, m ³ /h
General parameters 3 <i>hidden for TYPE "value"</i>	Target value 2	0 to 50000 kW
	Target value 3	0 to 50000 kW
	Target value 2 address selection	I00 to I50
	Target value 3 address selection	I00 to I50
	*Pact 2 max lim.	0 to 60000 kW
	*Pact 3 max lim.	0 to 60000 kW
General parameters 4	Tariff switching	bus, internal, input
	Start LT	00:00 to 23:59
	End LT	00:00 to 23:59
	*Limit max. Pact 1	0 to 60000 kW
	*LIM min. Pact	0 to 50000kW
	Address *LIM relay max. Pact	O 41 to O 47, O 40 = deactivated
	Address *LIM relay min. Pact	O 41 to O 47, O 40 = deactivated

*lim. = limit

Prewarning contact parameters:	
TYPE	Negative compensation power greater than available switch-off power
	Cumulated power greater than power warning threshold
	Trend power greater than power warning threshold
	Off (function deactivated)
Warning threshold	30 to 150 percent
Hysteresis	0 to 50000 kW
Minimum on time	0 to 999 minutes
Minimum down time	0 to 999 minutes
Period time-out	0 to 999 minutes
Prewarning contact address	Fixed at O 48

Parameters		Setting ranges
Line parameters	Power	0 to 9999 kW
	Priority	01 to 32
	TYPE	Standard, therm. Electrical load
	on switch-off	open, closed
	active	yes, no
	Mode	Auto, On, Off
	Feedback input address	100 to 150
	Feedback type	Enable, Manual On, Manual Off, priority, Emergency_On, Emergency_Off
	Actual Pact address	100 to 150
	Switch off in event of error	yes, no
	Period time-out	0.0 to 999 minutes
	Lead time	0 to 999 seconds
	Shut-off delay	0 to 999 seconds
	Minimum on time/day	0 to 24 hours
	Minimum on time	0 to 999 minutes
	Minimum off time	0 to 999 minutes
Maximum off time	0 to 999 minutes	

Parameters		Setting ranges
Meter inputs	Input 1	+/- 1 00 to 1 50
	Input 2	+/- 1 00 to 1 50
	Input 3	+/- 1 00 to 1 50
	Input 4	+/- 1 00 to 1 50
	Input 5	+/- 1 00 to 1 50
	Meter pulse monitoring	00:00 am to 11:59 pm
	M1 max. interval	0 to 999 seconds
	M2 max. interval	0 to 999 seconds
	M3 max. interval	0 to 999 seconds
	M4 max. interval	0 to 999 seconds
	M5 max. interval	0 to 999 seconds
Module management	Basic module	
	No additional models	Max. 20 additional modules, either relay output modules or digital input modules
	Module bus scan timeout (basic module)	0 to 5 seconds
	Module bus timeout (additional modules)	0 to 5 seconds
I/O parameters	Basic module	
	Inputs 1 to 5	Pulse counter, tariff switching, synchronous input, digital input
	Outputs 1 to 6	Relay output, error message relay, limit relay
	Output 7	Digital output
	inverse	yes, no
Timer programs:	Number	of the timer program
	Enable	0 = not enabled, 1 = enabled
	Active	0 = inactive, 1 = active
	Action	that the timer program carries out
	Mode	Current status
Measured value output	Channels 1 to 4	Output address
		Measured value (Pact, Pcum, Ptrend, etc.)
		Input address (for measured value "input")
Clock / date	Daylight saving time	Auto, Off
	Start	Months 01 to 12
	End	Months 01 to 12
Bus parameters	Bus address	0 to 9999

Parameters		Setting ranges
Display parameters	Contrast	60 to 100%
	Brightness	0 to 100%
	inverse	yes, no
	Language	German, English
	Dimming brightness	0 to 100%
	Dimming time	0 to 255 minutes

Error message dialog:

Parameters		Setting ranges
	E 01 power failure	Message, message and error message relay, off
	E 02 limit violated	Message, message and error message relay, off
	E 04 synchronous pulse missing	Message, message and error message relay, off
	E 05 reset performed	Message, message and error message relay, off
	E 07 error message	Message, message and error message relay, off
	E 09 Ptarg exceeded	Message, message and error message relay, off
	E 15 module bus error	Message, message and error message relay, off
Emergency shut-down	E 17 Pcum > Ptarg	Message, message and error message relay, off
Emergency shut-down	E 18 max. Pact limit violated	Message, message and error message relay, off
	E 19 min. Pact limit violated	Message, message and error message relay, off
Emergency shut-down	E 22 meter pulse 1 failure	Message, message and error message relay, off
Emergency shut-down	E 23 meter pulse 2 failure	Message, message and error message relay, off
Emergency shut-down	E 24 meter pulse 3 failure	Message, message and error message relay, off
Emergency shut-down	E 25 meter pulse 4 failure	Message, message and error message relay, off
Emergency shut-down	E 26 meter pulse 5 failure	Message, message and error message relay, off
Password	Code	Digits, four-digit

Exceeding maximum target values can be avoided through the targeted and **immediate** shut-down of relevant devices (the emergency shut-down must be activated for the optimization line).

Any programmed measuring period time-outs and minimum on times are not taken into account.

The following errors can trigger a shut-down:

- the cumulated measurement period power is greater than the target value
- the “maximum current power” limit has been exceeded
- Meter 1 meter pulse failure
- Meter 2 meter pulse failure
- Meter 3 meter pulse failure
- Meter 4 meter pulse failure
- Meter 5 meter pulse failure

6 Error message overview:

Global error state

Error no.	Explanation
E01	Mains failure has occurred
E02	A limit has been violated
E04	External synchronous pulse missing
E05	Reset has been performed
E07	Error message (1 when relay is switched, 0 if not)

multimax 4D6 local error state

Error no.	Explanation
E09	Maximum period target value exceeded
E10	Value has fallen below minimum period target value
E13	Battery voltage critical
E14	Parameter error (default value replaces incorrect value)
E15	Module bus error
-	Advanced error messages (error state is reset automatically)

Advanced error messages

Error no.	Explanation
E17	Maximum period target value exceeded
E18	Upper Pact limit exceeded
E19	Lower Pact limit exceeded
E20	Prewarning active
E22	Meter pulse 1 failure
E23	Meter pulse 2 failure
E24	Meter pulse 3 failure
E25	Meter pulse 4 failure
E26	Meter pulse 5 failure
E28	Module 20 cannot be reached
E29	Module 19 cannot be reached
E30	Module 18 cannot be reached
E31	Module 17 cannot be reached
E32	Module 16 cannot be reached
E33	Module 15 cannot be reached
E34	Module 14 cannot be reached
E35	Module 13 cannot be reached
E36	Module 12 cannot be reached
E37	Module 11 cannot be reached
E38	Module 10 cannot be reached
E39	Module 9 cannot be reached
E40	Module 8 cannot be reached
E41	Module 7 cannot be reached
E42	Module 6 cannot be reached
E43	Module 5 cannot be reached
E44	Module 4 cannot be reached
E45	Module 3 cannot be reached
E46	Module 2 cannot be reached
E47	Module 1 cannot be reached

7 Overview of system parameters

You can program the **multimax 4D6** to adapt it to the system to be optimized. The following are programmed:

- „General parameters“
- „Line parameters“
- „Meter inputs“
- „Module management“
- „I/O parameters“
- „Timer programs“
- „Measured value output“
- „Clock time / date“
- „Bus parameters“
- „Display parameters“
- „Error message parameters“
- „Password“

Menu navigation in the **multimax 4D6** is self-explanatory.

```
main menu
common parameter
line parameter
counter inputs
ModuleManagement
I/O parameter
Time programs
measurment. output
←   +   | Enter
```

```
main menu
Time / Date
Bus Parameter
display paramet.
err.mess. param.
Password
←   +   | Enter
```

8 Description of parameters

8.0.1 General parameters

In the general parameters area, you can adjust the most important general settings. Whichever parameter you chose, you have access to three or four areas.

1. From the main menu, select **Gen. parameters** > **Enter**.
2. Begin programming by selecting Edit.

Gen. param. 1	Programming	Explanation
TYPE	Selection: Value, switch inp., target value list	You can define a fixed value as a target value or switch between several values. By selecting switch inp. , i.e. switching the target value using another input signal, you can program these inputs and the associated target values in the Gen. Param. 3 area. Optionally, a target value list can also be processed.
Target value 1	Numeric value in kW, MW, m3/h	Enter the value here that has been agreed by the energy supplier.
Degree of optimization	Numeric value in %	Enter the percentage value of the optimal state (100%) that the device should achieve.
period duration	Numeric value in min	Enter the value here that has been agreed by the energy supplier.
Switching interval	Numeric value in sec	Time between two switching operations
Synchronization	Selection: Internal, inp., bus	Sets the synchronization type for the period start time.

Internal target value list

The device can process an internal target value list. This may be a daily, weekly or monthly target value list.

Target value entries:

Daily target value list Max. 96 target value entries

Weekly target value list Max. 7 target value entries

Monthly target value list Max. 31 target value entries



In the main menu – General parameters 1, the following target values may be selected:

- Value
 - the fixed target value 1 is used
- Switch-input
 - Target values 2 and 3 can be activated by customizable inputs
- Target value list
 - the internal target value list is processed

If, however, the target value is to be provided by an internal or external (via the KBR eBus) timer program, this has priority.



Note

The system can be implemented as a monitor of maximum or minimum values.

Gen. param. 2	Programming	Explanation
Minimum monitoring	On/Off	Monitors the minimum recovery in the case of a self-generated supply and contractually-agreed energy recovery into the energy supplier network.
Pact monitoring (Mode)	On/Off	Period-independent monitoring of whether current power exceeds the set target value (the stages are switched off if exceeded and switched back on if the stage power is free). If current power monitoring mode is activated, the cumulated power is generally no longer used for calculating the compensation power. Here, the compensation power is the difference between the active target value and the current power.
Target value track.	Numeric value in %	Maximum value of target value tracking.
ext. Pcorr default	On/Off	On deactivates the internal target value setting if a target value of an external system is to be used.
Energy type	Numeric value	Energy type, e.g. 00 = Electricity HT
Unit	Selection: kW, MW, m³/h	Set the unit type for electricity or gas

The following energy types can be selected:

Energy type	Tariff no.	Description
00	0	Electricity – high tariff
00	1	Electricity – low tariff
01	0	Water
01	1	Water
02	0	Gas
02	1	Gas

Energy type	Tariff no.	Description
03	0	Heat
03	1	Heat
04	0	Cryogenic power
04	1	Cryogenic power

Gen. param. 3 (only when selecting switch inp. as TYPE in the Gen. param. area 1)	Programming	Explanation
Target value 2	Numeric value in kW, MW, m³/h	Enter the value here that has been agreed by the energy supplier.
Target value 3	Numeric value in kW, MW, m³/h	Enter the value here that has been agreed by the energy supplier.
Adr. TV2 selection	Input I...	Input of a connected module for target value switching.
Adr. TV3 selection	Input I...	Input of a connected module for target value switching.
Max. Pact2	Numeric value in kW, MW, m³/h	Maximum permissible current power.
Max. Pact3	Numeric value in kW, MW, m³/h	Maximum permissible current power.

Gen. param. 4	Programming	Explanation
Set tariff	Bus, intrn, inp.	Determines whether the tariff switching time is input via the bus, the tariff switching input, or is defined internally. When intrn is chosen, the start LT and end LT parameters are active for programming the low tariff period
Max. Pact1	Numeric value in kW, MW, m³/h	Maximum permissible current power for this target value.
Min. Pact	Numeric value in kW, MW, m³/h	Minimum permissible current power.
Max. Pact limit adr.	Outputs O41–O47	Max. Pact. message output address
Min. Pact limit adr.	Outputs O41–O47	Min. Pact. message output address

Current power monitoring max. Pact1 limit, max. Pact2, max. Pact3

The lines are switched off according to priority and switching cycle. This requires that $Pact > max. Pact\ lim$. This can be set in General parameters 3 or 4 (according to which target value is active).

Maximum prewarning contact:

The default contact setting is closed, when active.

Prewarning contact parameters:

TYPE	Selection	Negative compensation power greater than available switch-off power
		Cumulated power greater than power warning threshold
		Trend power greater than power warning threshold
		Off (function deactivated)
Warning threshold	In % of active target value	30 to 150 percent
Hysteresis	in kW	0 to 50000 kW
Minimum on time	in minutes	0 to 999 minutes
Minimum down time	in minutes	0 to 999 minutes
Period time-out	in minutes	0 to 999 minutes
Prewarning contact address	0 48	fixed

```

Prewarning contact
-----
TYPE                Pcum>Pthresh
Warn.threshold      30%

On      min.        0.2 min
Aus     min.        0.2 min
(Off)   min.
Per.time-out       0.0 min
Prewarning contact adr.  A48
|  ←  |             |  +  |  Edit  |
    
```

Default values:

Prewarning contact active		
TYPE		-Pcorr > Pavail
Minimum on time	in minutes	0.2 minutes (=12 sec.)
Minimum off time	in minutes	0.2 minutes (=12 sec.)
Period time-out	in minutes	0 minutes
Prewarning contact address	O 48	Cannot be changed

Default setting function:

The contact switches when the compensation power is negative if there is no longer any line to switch off and the trend power is greater than the target value.

There is no hysteresis for the compensation power (if Pcorr fluctuates around 0).

The maximum prewarning contact is activated through the assignment of the virtual output O48 to a relay output (in I/O management).

Programming example:

Function type: Cumulated power greater than power warning threshold

Prewarning contact active		
TYPE		Pcum > Pthresh
Warning threshold	In % of active target value	90 percent
Minimum on time	in minutes	0.5 minutes
Minimum off time	in minutes	1.0 minutes
Period time-out	in minutes	10 minutes
Prewarning contact address	O 48	Cannot be changed

Currently-active period target value: 100kW

Warning threshold: 90% (corresponds to 90 kW)

Hysteresis: 10 kW

Minimum on time: 0.5 minutes (corresponds to 30 seconds)

Minimum down time: 1.0 minutes (corresponds to 60 seconds)

Period time-out: 10.0 minutes

The result is the following:

The contact switches if the cumulated power is greater than 90 kW (90% of the target value) and the message **E20 prewarning contact active** is issued.

No hysteresis is available, as the cumulated power only increases during the measuring period.

The contact remains switched until the measuring period ends. It drops at the beginning of the next measuring period because the cumulated power restarts below the warning threshold.

However, the prewarning contact is not deactivated if the minimum on time has not yet elapsed.

The message **E20 prewarning contact active** is issued when the contact is switched off.

When a measuring period is first started, the prewarning contact function is locked for the first 10 minutes (measurement period time-out). This means that the prewarning contact is not active or is deactivated (if the contact was active at the end of the previous period and no minimum on time is applied).

The measurement period time-out is always started at the beginning of a measurement period. The minimum on and off times take priority over the measurement period time-out.

Programming example:

Function type: Trend power greater than power warning threshold

Prewarning contact active		
TYPE		Ptrend > Pthresh
Warning threshold	In % of active target value	90 percent
Hysteresis	in kW	10 kW
Minimum on time	in minutes	0.5 minutes
Minimum off time	in minutes	1.0 minutes
Period time-out	in minutes	10 minutes
Prewarning contact address	O 48	Cannot be changed

Currently-active period target value: 100kW

Warning threshold: 90% (corresponds to 90 kW)

Hysteresis: 10 kW

Minimum on time: 0.5 minutes (corresponds to 30 seconds)

Minimum down time: 1.0 minutes (corresponds to 60 seconds)

Period time-out: 10.0 minutes

The result is the following:

The contact switches if the trend power is greater than 90 kW (90% of the target value) and the message I20  warning contact active is issued.

The hysteresis for switching back is 10kW, meaning that the contact will switch back if the trend power is 80 kW (90% of the target value minus a hysteresis of 10kW).

The contact remains switched on for 30 seconds even if the trend power falls under 80 kW during this period.

After the contact is switched off, the next switching operation is carried out after a minimum of 60 seconds, as the minimum off time is still applicable. The message **E 20 prewarning contact active** is issued when the contact is switched off.

When a measuring period is first started, the prewarning contact function is locked for the first 10 minutes (measurement period time-out). This means that the prewarning contact is not active or is deactivated if the minimum on time has not yet elapsed.

The measurement period time-out is always started at the beginning of a measurement period. The minimum on and off times take priority over the measurement period time-out.

9 Line parameters

The following assignments have been set for inputs (I) and outputs (O):

Inputs: I 00 to I 50

Outputs: O 00 to O 50

Whereby:

- O 01 to O 32 correspond to lines 1 to 32
(i.e. are permanently assigned to the lines)
- O 33 to O 39 = free
- O 40 = limit relay deactivated
- O 41 to O 47 = free (e.g. for limit relays or analog outputs)
- O 48 = Prewarning contact (permanently assigned to the function)
- O 49 = Error message contact (permanently assigned to the function)
- O 50 = Basic module digital output (permanently assigned to the functions)

In the Line parameters area, you can adjust the required settings for your devices.

1. From the main menu, select **Line parameters** > **Enter**

Li	MC	Adr	P	Pr	Ac
Line number	Three-digit number. Digits 1 and 2 represent the module (00 is the basic module) and digit 3 represents the contact number	Address	Configured power/consumption	Device shut-down priority: the device with priority 1 is shut down first, then the device with priority 2, etc.	Device deactivated/activated

2. Select a line and begin programming with **Para** and **Edit**.

Para Line (1, 2, etc.)	Programming	Explanation
Power	Numeric value in kW, MW, m³/h	Device power.
Priority	Numeric value 1–32	Device shut-down priority. The default setting is the line number.
TYPE	Standard, therm., signal, controllable	Standard, therm. Device, controllable device (via analog output), signal (in development)
on switch-off	open, closed	Defines whether the device is switched off when the contact is closed/opened.
active	On/Off	An activated optimization line is integrated into the optimization cycle.
Mode	Auto, Off, On	Defines whether the device is integrated into optimization (Auto), remains constantly on, or remains constantly off.

Notes on the line parameters

a) Power

b) Priority

c) Type:

a) Power

The power consumption should be entered **manually** here. A device's current power consumption can also be determined using the additional modules multimes 1D4 or multisio 2D2-4AI.

Determining a device's current power using multimes 1D4:

Using this function, a device's actual current power consumption can be determined. In this way, a suitable time for shut-downs that are necessary for optimization reasons can be determined (load-dependent power consumption).

The device's programmed power consumption (line parameters) is used in this case only for switching on the device. Settings per measuring channel: in the case of three-phase power, the measured

power per channel is extrapolated to a three-phase device.

multimes 1D4 I/O parameters channel 4 (mixed channel), 3-phase measuring:

- Channel name
- Primary transformer voltage value (taken from channels 1 to 3)
- Secondary transformer voltage value (taken from channels 1 to 3)
- Primary transformer current value (taken from channels 1 to 3)
- Secondary transformer current value (taken from channels 1 to 3)
- Measurement type: consumption
- Settings per measuring channel: Single-phase power



Note

When connecting the multimes 1D4 measuring module, it must be ensured that the measuring voltage is not switched off with the device, as the module receives its supply voltage from the measuring voltage.

In the case of single-phase measuring, it also should be ensured that the transformers are in phase with the measuring voltage.

Recording power using the analog input module multisio 4AI:

The analog input module multisio 4AI can record a current of 0 to 20 mA DC or a voltage of 0 to 10 V DC via each of its four analog inputs.

By appropriately configuring the inputs (minimum value, maximum value), a current power value can be established and forwarded for further processing. In this way, a suitable time for shut-downs that are necessary for optimization reasons can be determined (load-dependent power consumption).

The device's programmed power consumption (line parameters) is used in this case only for switching on the device.

The following parameters are available for each input:

- Module name
- Range selection
- Minimum value in kW
- Maximum value in kW
- Consumption power type

b) Priority

The programmed priority (the device shut-down order) can be changed using a timer program (see **Timer programs** chapter).

c) Type

A standard device is switched on and off based on its programmed power (taking into account any programmed time-outs).

The standard parameters are set for this device type. Parameters (example):	
Power	18 kW
Priority	01
Type	Standard
on switch-off	Open
active	yes
Mode	Automatic
Period time-out	0 minutes
Lead time	0 seconds
Shut-off delay	0 seconds
Minimum on time/day	0 hours
Minimum on time	0 minutes
Minimum down time	0 minutes
Maximum off time	0 minutes

Thermal devices

In addition to the standard parameters, the following parameters are available for this device type:

- The evaluation of the state of the device main switch via a digital input or, in the case of the multimes 1D4, via a voltage input
- The evaluation of the state of the device thermostat switch via a digital input or, in the case of the multimes 1D4, via a voltage input
- Optimization in the heat-up phase and the continued heating phase can be optionally activated or deactivated.

The following parameters are available (example):

Power	18 kW
Priority	01
Type	Thermal device
on switch-off	Open
active	yes
Mode	Automatic
Main switch input address	I 06
Thermostat switch input address	I 07
Optimization in the heat-up phase	yes

Optimization in the continued heating phase	yes
Maximum on time	0 minutes
Period time-out	0 minutes
Lead time	0 seconds
Shut-off delay	0 seconds
Minimum on time/day	0 hours
Minimum on time	0 minutes
Minimum down time	0 minutes
Maximum off time	0 minutes

Application examples:

Optimization in the heat-up phase	yes
Optimization in the continued heating phase	yes

Output state:

Main switch input address	Open (main device switch is off)
Thermostat switch input address	Closed (device is heating up)
Reason for optimization line switching	On/enable/0
This means that: the device is switched off, because there is no operating state feedback available from the device to integrate it into optimization.	

The main switch is switched on:

Main switch input address	closed
Thermostat switch input address	Closed (device is heating up)
Reason for optimization line switching	On/optimization/1
This means that: the device is switched on, there is operating state feedback available from the device and the device could be switched off for optimization reasons.	

Thermo-switch opens:

Main switch input address	closed
Thermostat switch input address	Open (device has reached its temperature)
Reason for optimization line switching	On/optimization/1
This means that: the device is now in the continued heating phase (after the thermostat switch first opens) and could be switched off for optimization reasons.	

No optimization in the heat-up phase:

Main switch input address	I 06
Thermostat switch input address	I 07
Optimization in the heat-up phase	no
Optimization in the continued heating phase	yes
Main switch input address	closed
Thermostat switch input address	closed
Reason for optimization line switching	On/heat-up/1
This means that: The device is in the heat-up phase and cannot be switched off for optimization reasons.	

The thermo-switch is not monitored:

Main switch input address	I 06
Thermostat switch input address	I 07
Optimization in the heat-up phase	yes
Optimization in the continued heating phase	yes
Main switch input address	closed
Thermostat switch input address	Open (not monitored)
Reason for optimization line switching	On/optimization/1
This means that: The device is immediately in the continued heating phase and could be switched off for optimization reasons.	

Cyclic operation (no forced cycles):

To set the device cycles, only the times

- Maximum on time

- Maximum off time

are programmed.

These times may not be followed to completion if

- in the case of max. off => there is already sufficient free power such that no further cycling must be carried out

- in the case of max. on => optimization has already been carried out

Display for programmed cyclic operation:

Line state on => The device is constantly on and there is sufficient free power available such that the device does not need to be cycled.

Line state off => The device is cycled, because there is not sufficient free power for constant operation.

Message in event memory => **Line switched off, reason: optimization.**

The switching interval configurable in the general parameters (in sec.) is not taken into account in cyclic operation.

Controllable devices

The multisiso 1D2-2AO can be used for this device type. If a controllable line is used, the multimax will attempt to configure the line output power such that the compensation power is zero and the trend power does not exceed the target value currently active. Irrespective of the actual device conditions, this will not happen immediately, which results in transient oscillation behavior.

The transient oscillation behavior does not depend on the programmed stage power. This is only determined when the next stage intervenes. The transient oscillation behavior is influenced by a real control loop: i.e. by the actuator (analog output module), the analog device and the measuring input (for Pact).

The delay times also influence the control behavior. The sum of the delay times (actuator, device, measuring input (pulses)) should be less than the switching cycle (risk: resonance in control loop). If the actuator is programmed such that the power change set by the controller at the measuring input leads to a larger power change, the controller will overshoot.

If the power change is less than that expected by the controller, the power to be adjusted will only be reached after several switching cycles.

Therefore, the actual conditions should be programmed as accurately as possible.

The line output power only changes in the switching cycle: once the output power has changed, it will not be changed again for the duration of the switching cycle.

Once output power reaches 0 or 100%, the next line is switched to (depending on the line priority). This is also the case for circuit switching (lines with the same priority).

The following parameters are considered:

- Minimum off time: Takes effect when the output power has reached zero.
- Minimum on time:
Takes effect when the output power is greater than zero. The output power can then not be reduced until the minimum on time has elapsed.

Additional notes:

On/off state:

When the output power is zero, then the state is "Off"

Otherwise, the state is "On." Switching reasons that switch the line on or off switch the power to 100% or 0% (e.g. Manual On/Manual Off). The period time-out switches the output power to 100%. Timer programs can currently only switch the analog lines off (0%) or on (100%). In the switching operations memory, only a change from 0% to greater than 0% and vice-versa is logged.

The following parameters are available:

1. Module name (module no., output no.)
2. Logical address O41 (example) to O47
3. Type: 10 V or 20 mA
4. min. value kW (+/-)
5. max. value kW (+/-)
6. Min. output value: 0 V or 0 mA
7. Max. output value: 10 V or 20 mA
8. Default value (output): 0 V or 0 mA
9. Edge (gradient) in milliseconds

Explanation:

Default value = output when power returns after power failure

Edge = change in output value in milliseconds (jump from min. to max.)

3. Program the address with **Adr** and **Edit**.

Para Lines (1, 2, ...)	Programming	Explanation
Adr. output	Numeric value O 01 – O 32, fixed	Device address, O 01–O 04 on the basic device; afterwards, numbering is continued for connected modules.
Adr. feedb.	I 00-I 50	The multimax checks whether the device is on or off and sends a message about this via the feedback input. If this does not occur, the multimax switches regardless of whether the device is on or off and then waits the set time until the next switching event.



Note

In addition to the digital input module inputs (for floating switches or electronic switches (ensure correct polarity)), the voltage inputs of the multimax 1D4 measuring module can also be used as feedback inputs. This module enables 230 VAC feedback (e.g. directly from the device main switch) to be evaluated, whereby an input voltage of > 70 VAC is evaluated as on.

4. Program the device's time-dependent parameters with **Time** and **Edit**.

Line times (1, 2, etc.)	Program- ming	Explanation
Per. Time-out	Numeric value in min	Defines the time that the device stays on from the start of the period under all circumstances.
Lead time	Numeric value in sec	Defines the lag time for turning the device on – the device only reaches its power after this time.
Shut-off delay	Numeric value in sec	Defines the lag time for turning the device off – the device power only reaches zero after this time.
Minimum on time/ day	Numeric value in hrs	Minimum time period for which the device must be switched on per day
Min. On Min. Off Max. Off	Numeric value in min	Minimum time period for which the device may be switched on or max./min. time period for which the device may be switched off in relation to a period.

Para Lines (1, 2, ...)	Programming	Explanation
Feedback type	Enable, Manual_Off, Manual_On, Emergency_Off, Emergency_On, priority 1–32	Defines whether the device is integrated into optimization via its feedback (enable), remains constantly on (Manual_On), or is switched off independently of its trend calculation (Manual_Off). In the case of running timer programs, there is an additional option to modify the process and influence the state of the optimization lines: Emergency_On (switches on the line in case of emergency) Emergency_Off (switches off the line in case of emergency) The current line priority can also be changed
Pact Adr.	Input I...	Message input address via which the current device power consumption is established using a power measuring module or analog input module.
Switch off in event of error	On/Off	Defines whether the device is switched off in event of error.
Power on state	On/Off	Determines the line state when the power returns after a power failure
Line group	0 to 65535	Line assignment to a line group

The following errors can trigger an emergency shut-down:

- the cumulated measurement period power is greater than the target value
- the “maximum current power” limit has been exceeded
- Meter 1 meter pulse failure
- Meter 2 meter pulse failure
- Meter 3 meter pulse failure
- Meter 4 meter pulse failure
- Meter 5 meter pulse failure

9.1 Meter inputs

In the **Meter inputs** area, you can set and configure inputs for meters.

1. From the **main menu**, select **Meter inputs** > **Enter**.
2. Begin programming by selecting **Edit**.

Meter inputs	Programming	Explanation
Input 1, 2, etc.	+/- I...	A + before the meter input adds the meter values to the total power and a - subtracts them from the total power, e.g. when a meter is measuring a self-generated energy supply.

Recording the operate values without sum offsetting:

Is it now possible to record a meter input (load profile memory, energy meters) without the value being added to or subtracted from the current power. This can be done by selecting "/" for the relevant meter input instead of "+" or "-". This means that the power of a photovoltaic device can be recorded without this power being included in the total power under consideration.

counter inputs						
Input	1	+I01				
Input	2	+I02				
Input	3	+I03				
Input	4	+I04				
Input	5	/I05				
<table border="1"> <tr> <td>↩</td> <td>Pact</td> <td>Para</td> <td>EDIT</td> </tr> </table>			↩	Pact	Para	EDIT
↩	Pact	Para	EDIT			

3. You can display the current values of each meter using **Pact**. This is only possible here.
4. Program meter pulse monitoring using **Para**.

9.2 Module management

In the Module management area, you can manage and program the basic and additional modules.

From the **main menu**, select **Module management > Enter**.

Select a module.

ATTENTION: If necessary, start a module scan using **Scan**. This function recognizes your connected modules; however, it only does so one after the other and if they are in scan mode.

Select a module from the list and begin programming with **Para**.

Para Module (0, 1, 2, etc.)	Programming	Explanation
Time-out	Numeric value in sec	Defines the time accepted for feedback from the module in network operation. This is particularly helpful for slower networks in terms of avoiding unnecessary error messages.
Flashing	On/Off	Makes the selected module's LEDs blink sequentially to be able to assign a number to a connected module.
Removal	On/Off	Deregisters an additional module from the basic module.

9.3 I/O parameters

In the I/O parameters section, you can define and program the inputs and outputs.

1. From the main menu, select I/O parameters > Enter.
2. Select an input/output from the list and define it with Edit.
 - The available inputs are: synchronous input, tariff, digital input and pulse counter.
 - The available outputs are: relay output, error message, limit mess. and digital output.
3. Select an input/output from the list and configure it with Para.

E.g. when defining as a pulse counter

Para (...) Input	Program- ming	Explanation
Log. address	I...	Fixed logical address.
inverse	On/Off	Determines whether the input reacts to a positive or negative pulse.
t Pact -> 0	Numeric value in sec	Determines the time before the power drops to 0.
Imp. val	Numeric value in I/kW, MW, m³	Pulse value as per energy supplier.
I/V prim/ sec	Numeric value in A/V	Transformer ratio Current/voltage

E.g. when defining as a relay output

Para (...) Outputs	Program- ming	Explanation
Log. address	O...	Configurable lines can be assigned to a terminal. The terminal is determined by hardware
inverse	On/Off	Determines whether the relay reacts to a positive or negative pulse.
Relay group	Numeric value in sec	Assigns the relay to a relay group (switches independently of the multimax)

When defining as a limit signaling relay, the following additional parameters are available:

t-delay: Delay until relay is switched

t-drop: Hold time beyond the duration of the limit violation

9.4 Timer programs

Time Programs			
no	EA	Action	Mode
01	11	linegroup	on
02	10	switchgrp.	off
03	10	tariff	HT
04	10	limit	Auto
05	10	priority	set
06	10	targetval	Auto
←	↓		Para

In the timer program overview, the following information is displayed:

- **Number** of the timer program
- **Enable** (0 = not enabled, 1 = enabled)
- **Active** (0 = inactive, 1 = active)
- **Action** of the program
- **Mode** (current state)

If a timer program is in Auto mode, the device functions with the values defined in the device (General parameters).

The following actions are available:

- Switch switch group
- Tariff switching
- Set limit
- Switch line group
- Set priority
- Set target value



Note

For „Set target value,“ in addition to the three target values programmed under Menu/General parameters, the target values from the target value list can also be used. These max. 96 entries (daily target value list) are managed as target values 4 to 99.

Setting the parameters:

Para. time prog	
	Prog 1
ID-No	1
TYPE	day
domain	07:30:00
start	01.01.2013
domain	16:15:00
end	01.01.2039
←	→ EDIT

Para. time prog	
enabling	✓
start	08:00
end	16:00
	su MO TU WE TH FR sa
action	linegroup
←	act. EDIT

**Note**

To start a programmed timer program, Enable must be activated and the time range must have been entered (time, date).

**Note**

The timer programs have a priority order corresponding to their ID no., where-by ID 01 is the most important timer program, then ID 02, etc.

When carrying out an action, timer programs (internal or external) always have priority over bus switching, digital input (manual switching) and device programming.

The device can manage and process up to 10 timer programs. The timer programs are divided into daily programs and weekly programs.

Daily programs:

One or more days can be selected on which the timer program runs. If the time of the final action is before that of the start action or at the same time (e.g. 04:00 am to 04:00 am), the end time will not be reached until the next day (irrespective of the day).

If the time is set to 00:00 am to 23:59 pm, the timer program runs for 24 hours on the same day.

Weekly programs:

The start and end day can be selected. The started function is active until the end day and is repeated in a weekly cycle. If the end day is before the start day (e.g. start day is Friday, end day is Monday), then the program runs, including over the weekend.

**Note**

For all daily and weekly programs, the month in which the program is to be active can also be selected. For example, January, February and December can be chosen, meaning that March to November are excluded.

9.5 Measured value output

measurēm. output	
channel	1
channel	2
channel	3
channel	4
←	↓
Enter	

Measured value output	Programming	Explanation
	Channels 1 to 4	Four programmable channels are available for measured value output
Measured value output	Output address	Addresses O 41 to O 47
	Measured value	See table below
	Input address	For "current input power" measured value

Available measured values:

- Current power P_{act}
- Cumulated power P_{cum}
- Trend power P_{trend}
- Compensation power P_{corr}
- Current power meter input 1 M1
- Current power meter input 2 M2
- Current power meter input 3 M3
- Current power meter input 4 M4
- Current power meter input 5 M5
- Current power input I 01 to I 50 (selectable)

9.6 Time/date

In the **Time/date** area, you can set the time and date and configure daylight saving time settings.

1. From the **main menu**, select **Time/date** > **Enter**.
2. Begin programming by selecting **Edit**.

Time/date	Program-ming	Explanation
Time	Numeric value in HH:MM:SS	Defines the time if this is not provided by an external system (eBus).
Date	Numeric value in DD:M-M:YYYY	Defines the date if this is not provided by an external system (eBus).
Daylight saving time	AUTO/OFF	AUTO activates daylight savings time automatically according to the data entered for Start and End.
Start	Numeric value from 1–12	Beginning of daylight savings time. The default is 03 (March).
End	Numeric value from 1–12	Beginning of daylight savings time. The default is 10 (October).
Runtime	Numeric value in DD HH:MM:SS	Indicates how long the multimax is in continuous operation.

9.7 Bus parameters

In the **Bus parameters** area, you can set the **KBR eBus** address.

1. From the **main menu**, select **Bus parameters** > **Enter**.
2. If necessary, start a bus scan using **scan**.
3. Begin programming by selecting **Edit**.

Bus param-eters	Program-ming	Explanation
TYPE	eBus fixed	Currently, only the KBR eBus is available as a bus.
Address	Numeric value 0–9999	Defines the bus address. You can either enter a fixed bus address or find and assign the bus addresses using SCAN mode (for each device individually).
Baud rate	Numeric value kBd	Defined by KBR and used as an indication of the bus speed.

9.8 Display parameters

In the **Display parameters** area, you can change the LED display settings.

1. From the **main menu**, select **Display parameters** > **Enter**.
2. Begin programming by selecting **Edit**.

Display parameters	Programming	Explanation
Contrast	Numeric value in %	Defines the text contrast in relation to the background.
Brightness	Numeric value in %	Defines the brightness of the background lighting.
inverse	On/Off	Defines whether dark text is displayed on a light background or light text is displayed on a dark background.
Language	Choice between German and English	Defines the display language.
Dimming brightness	Numeric value in %	Decreases the display brightness to the given percentage.
Dimming time	Numeric value in min	Decreases the display brightness as per the given time to the value set under Dimming brightness . This makes sense if you want to work on the device for a while and then dim the display to save energy. After dimming, the display returns to its original brightness once a key is pressed.
Version	Number/letter combination	Information on the display version.

3. Test the display for pixel errors with **test**.
 4. Press **OK** if the horizontal lines are correctly displayed.
 5. Press **OK** if the vertical lines are correctly displayed.
 6. Test the function keys by following the instructions on the device.
- After pressing all function keys, you are returned to the menu.

9.9 Error message parameters

In the **Error message parameters** area, you can set the type of message for different errors.

1. From the **main menu**, select **Error message param.** > **Enter**.
2. Begin programming by selecting **Edit**.

Error message param.	Programming	Explanation
Error message parameter type	Mess., Mess. Rel. + Mess., Off	<p>Mess. simply sends an error message if there is an error of this type.</p> <p>Mess. Rel. + Mess. sends a message and activates an error message relay.</p> <p>Off triggers no action.</p>

You can find a list of all parameters in the "Error message parameters" menu.

9.10 Password/reset

In the **Password** area, you can define a password to protect the device from unauthorized inputs and reset the password. Here you can also reset the device to factory settings.

1. From the **main menu**, select **Password** > **Enter**.
The device displays "Unlocked," meaning the standard value 9999 has not been changed and the device does not require a password to enter data.
2. Begin programming by selecting **Edit**.
3. Enter a four-digit figure as a password.

The device now displays **Lckd** . You now must enter a password when you want to enter data into the device.

When you have unlocked the device with the password, the device will relock itself after a few minutes.

RESET PASSWORD

You can unlock the device if you no longer require a password.

- Unlock the device using the current password and enter **9999** as a password in the **Password** menu.

The device displays **Unlocked**, meaning the standard value **9999** has been reinstated and the device does not require a password to enter data.

RESET

You can reset the device to factory settings if you no longer need your current settings.

1. Select **Reset**.
2. Select **Edit**.
3. Select **Reset to factory settings**.
4. Confirm with **YES**.

All of your settings are lost and the device is reset.

10 Description of display items

10.1 P actual

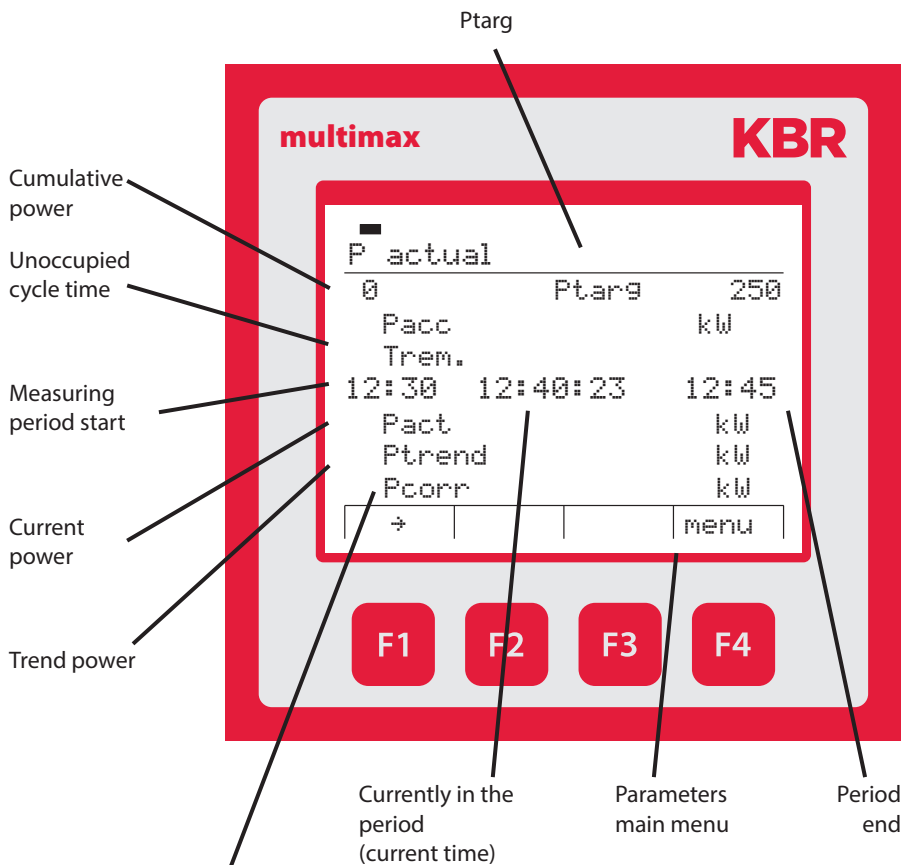

If this value reaches the value of a configured device, a device is switched off (when compensation value is negative) and switched on (when the compensation value is positive) as per the stage parameters.

10.2 Potential

Power values of all devices that can still currently be switched off

Lines with this power have already been switched off

Lines with this power have been switched off

Power in the previous period (exceeded, target reached, fallen short)

Highest daily period value

Highest monthly period value

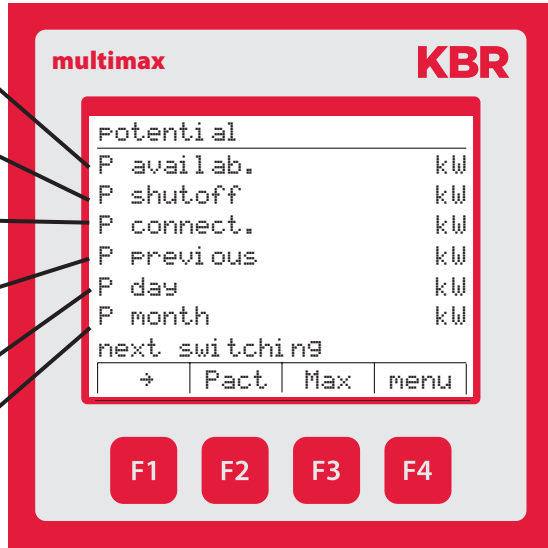

Measuring period maximum values: (with respect to the active target value)

Use the **F3** key to display the maximum values for target values 1, 2 and 3.

Daily maximum:

Max 1: Value, date, time

Max 2: Value, date, time

Max 3: Value, date, time

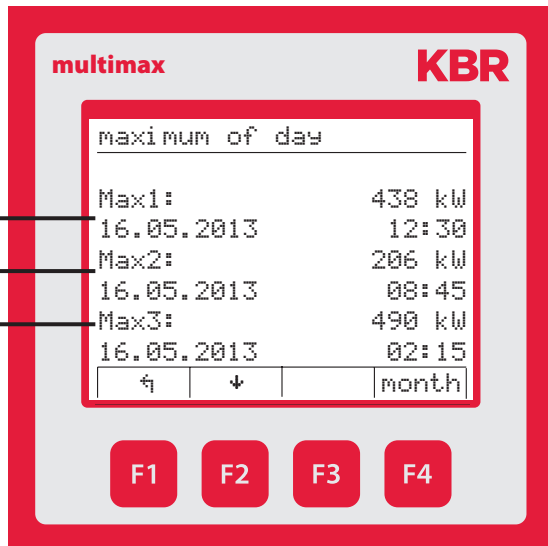

Use the **F4** key to switch the display from the daily maximum to the monthly maximum values.

Monthly maximum:

Max 1: Value, date, time

Max 2: Value, date, time

Max 3: Value, date, time

Use the **F2** key to display the maximum values from the previous month and other previous months going back 12 months.

Use the **F4** key to switch the display from the monthly maximum to the annual maximum values.

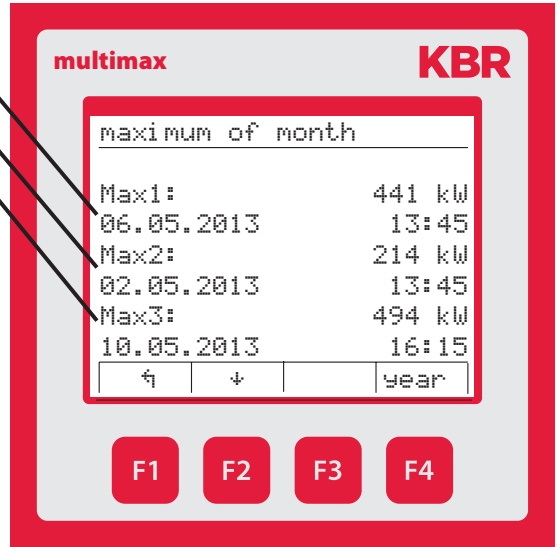
**Annual maximum:**

Max 1: Value, date, time

Max 2: Value, date, time

Max 3: Value, date, time

Use the **F4** key to switch the display of the annual maximum back to the daily maximum values.

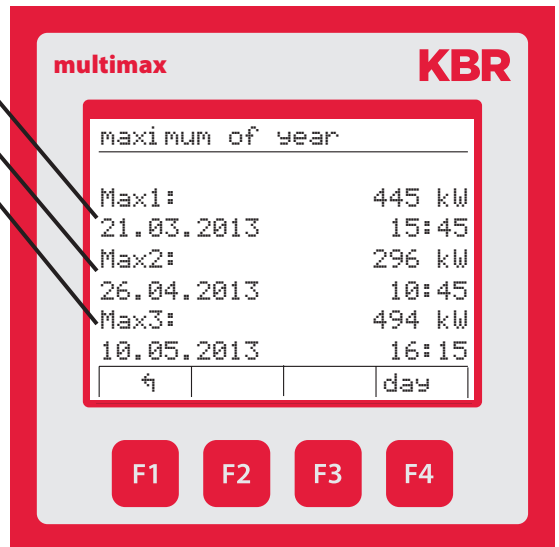
**Note**

If a target value list is being processed, the max. values are registered at target value 1.

10.3 Line data

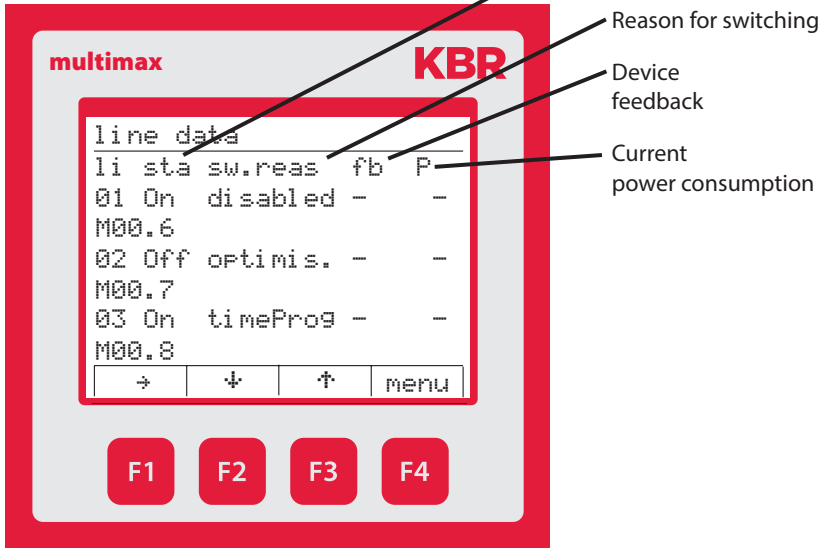

In the Line data menu, in addition to the items

- Line number (Li)
- Switching output state for the device (Sta)
- Reason for switching (S.reason)
- Device feedback input (Fb, state (if available))

the item

- Current device power consumption (P) (measured using multimes 1D4, if available)

is displayed.

10.4 I/O state

Recording input and output states

Connected/not connected

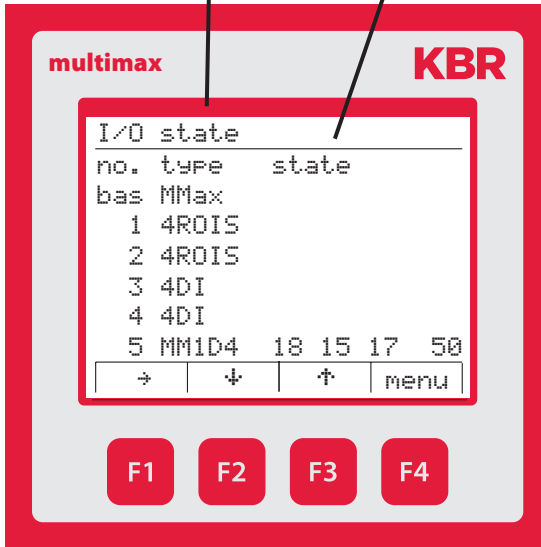

Possible messages:

- i No pulse at pulse input (low level)
- I Pulse detected at pulse input (high level)
- o Output passive (relay or pulse)
- O Output active (relay or pulse)

In the I/O state menu in the additional module multimes 1D4 (if available), the measured current power of the three phases and the total power, as per the configuration of the measuring module, are displayed in the State column.

Example: L1 = 18 kW, L2 = 15 kW, L3 = 17 kW, Ptotal = 50 kW

10.5 Tracked Ptarg

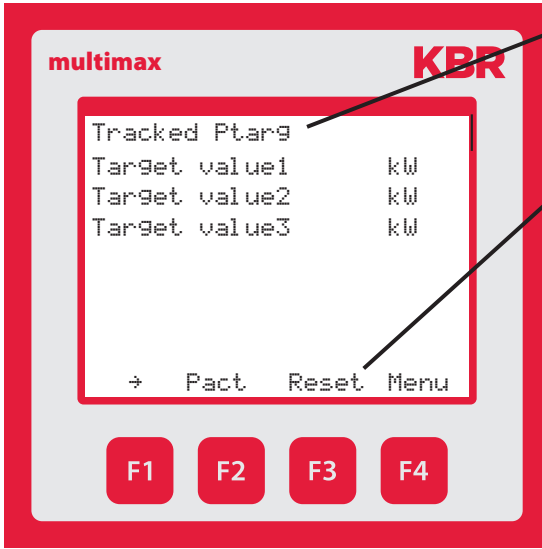

Display of the set target values or the tracked target values, if target value tracking is activated

Resets to the configured target value

10.6 Meter values

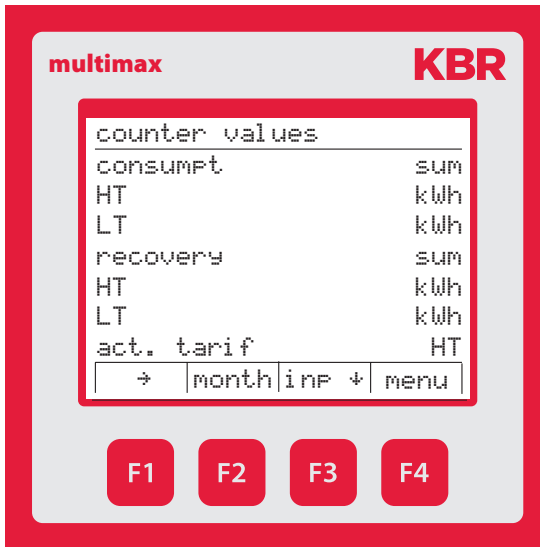

In the Meter values menu, in addition to the current tariff, the following values can also be displayed:

Total values
up to now

Continuous energy meter
Total HT consumption

Continuous energy meter
Total LT consumption

Continuous energy meter
Total HT recovery

Continuous energy meter
Total LT recovery

Use the **F3** key to display meter inputs meter 1 to meter 5 individually.

Use the **F2** key to display

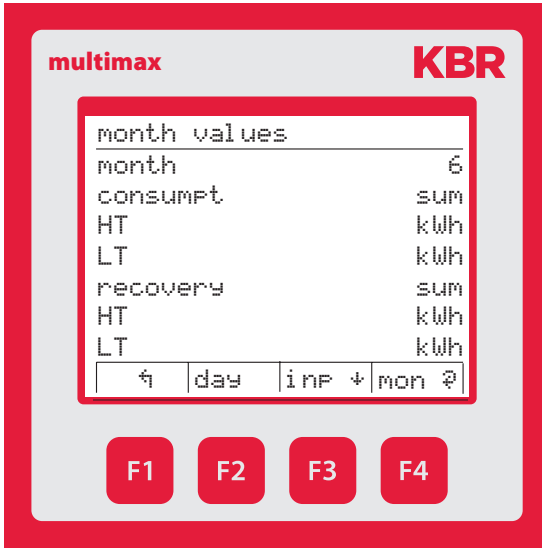

Monthly values – current month

Continuous energy meter
Total HT consumption

Continuous energy meter
Total LT consumption

Continuous energy meter
Total HT recovery

Continuous energy meter
Total LT recovery

Use the **F3** key to display meter inputs meter 1 to meter 5 individually.

Use the **F4** key to switch from the display of the current month to the previous month.

Use the **F2** key to display

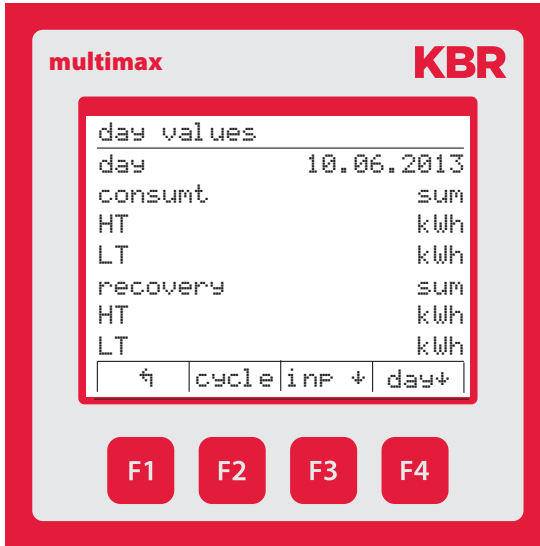

Daily values

Continuous energy meter
Total HT consumption

Continuous energy meter
Total LT consumption

Continuous energy meter
Total HT recovery

Continuous energy meter
Total LT recovery

Use the **F3** key to display meter inputs meter 1 to meter 5 individually.

Use the **F4** key to switch from the display of the current day to the last 30 days, starting with the most recent.

Use the **F2** key to display

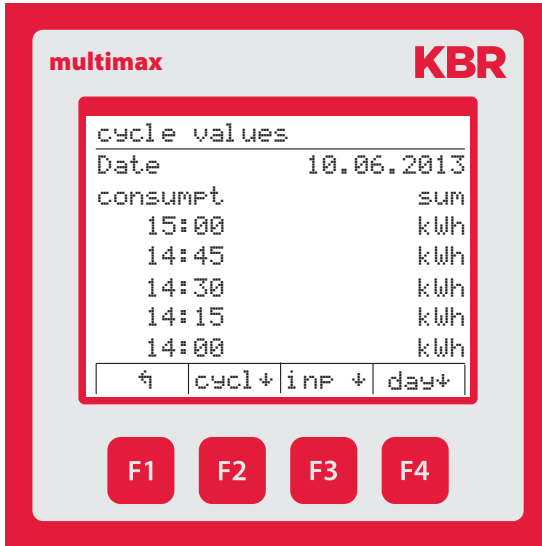

Period values

Period values in
period duration grid

Consumption and recovery

Use the **F2** key to display the period values, starting with the latest.

Use the **F3** key to

- display meter inputs meter 1 to meter 5 individually.
- Display of respective active target value for the period
- Display of reduced power in the relevant period (saving)

Use the **F4** key to switch from the display of the current day to the last 30 days, starting with the most recent.

10.7 Current error messages

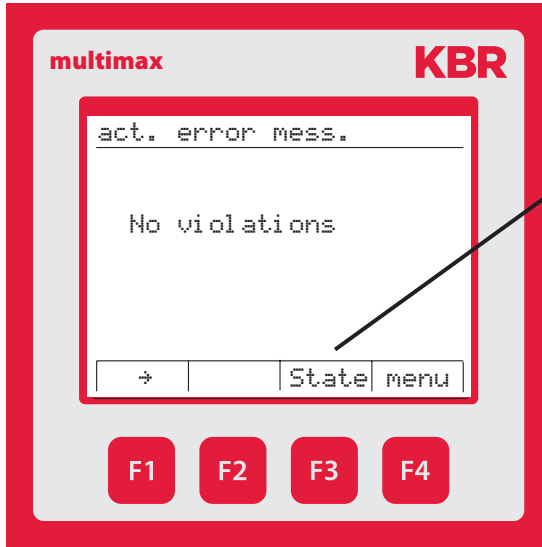

Active error messages do not have to be acknowledged and disappear when the error is resolved

Messages that have to be acknowledged (Del.) e.g. lim. violated, power failure

11 Technical data multimax 4D6

11.1 General technical data for additional modules

Power supply:	Via module bus	24 VDC/approx. 2W for multimes 1D4 only for the interface RS485 24 VDC/approx. 0.3 W
	Connection	Modular connector RJ12 6P6C
Module bus interface:	serial interface	RS485
	Module bus connection	RJ12 for ready-made KBR system cable, max. length 30 m when placed suitably
	Transmission speed	38400 Bps
	Bus protocol	KBR module bus

Mechanical data (for all models except for multisio 1D4-4RO-ISO and multimes 1D4):

Top hat rail device	Housing dimensions	90 x 36 x 61 mm (H x W x D)
	Mounting type	Wall mounting on DIN rail 7.5 mm deep, in accordance with DIN EN 50022. Suitable for distribution board mounting
	Weight	Approx. 100g

Mechanical data multisio 1D4-4RO-ISO:

Top hat rail device	Housing dimensions	90 x 70 x 61 mm (H x W x D)
	Mounting type	Wall mounting on DIN rail 7.5 mm deep, in accordance with DIN EN 50022. Suitable for distribution board mounting
	Weight	Approx. 130g

Mechanical data multimes 1D4:

Top hat rail device	Housing dimensions	90 x 70 x 61 mm (H x W x D)
	Mounting type	Wall mounting on DIN rail 7.5 mm deep, in accordance with DIN EN 50022. Suitable for distribution board mounting
	Weight	Approx. 175g

Standards and Miscellaneous:		
Ambient conditions:	Standards	DIN EN 60721-3-3/A2: 1997-07; 3K5+3Z11; (IEC721-3-3; 3K5+3Z11)
	Operating temperature	-5°C ... +55°C
	Humidity	5% ... 95%, non-condensing
	Storage temperature	-25°C ... +70°C
Electrical safety	Standards	DIN EN 61010-1/A2: 2001 + B1: 2002-11 + B2: 2004-1; (IEC1010-1/A2)
	Protection type	IP20 in accordance with DIN EN 40050 part 9:1993-05
	Electromagnetic compatibility	DIN EN 61000-6-3: 2001 + A11: 2004; (IEC61000-6-3) DIN EN 61000-6-2: 2001 (IEC61000-6-2)

11.2 Technical data for multimax 4D6 basic module

11.2.1 Operating and display elements

Operation	Pushbutton for reset and scan mode (accessible after housing cover removal)
Control display	6 green LEDs: 5 x input status, 1 x operating status

11.2.2 Device memory

Energy, data and program memory	2 MB RAM battery-buffered/ 256k Flash
Memory type	Ring buffer
Long-term memory for max. 160 days, min. 64 hours, depending on memory configuration	Load profile memory: Maximum of 4*3840 entries; 60 / 30 / 15 / 1 min. interval duration
Event memory	A maximum of 4096 entries to record tariff switching commands, mains failures, error messages etc.
Parameter memory	non volatile
Switching operations memory	Maximum of 2450 entries
Operation logbook	Maximum of 512 entries
Timer programs:	Maximum of 512 entries
Password memory	4-digit code

11.2.3 Power supply

Power supply	85 to 265V AC/DC; 50/60Hz
Power consumption	15 VA

11.2.4 Hardware inputs

Digital inputs	As pulse counter input 1 to 5	Digital input for floating contact, S_0 compatible, pulse length ≥ 30 ms
	As status input	Digital input for floating contact, S_0 compatible, e.g. to synchronize the measuring interval; pulse length ≥ 250 ms

11.2.5 Electrical connection

Connection elements		Screw terminals
Max. permissible connection line cross-section		2.5 mm ²
Input power supply	Fuse protection	F1: Recommended: 1A slow-blowing < fuse < 4 A slow-blowing
KBR eBus connection	Connection material	For proper operation, use shielded twisted-pair cables only, e.g. I-Y(St)Y 2x2x0.8
Pulse inputs	Connection and cables	Ensure proper polarity!
Synchronous input	Connection and cables	Ensure proper polarity!
KBR eBus connection	via RS485	Terminal 90 (L) Terminal 91 (A) Terminal 92 (B)

11.2.6 Hardware outputs

Interface	Serial interface	RS 485 for connection to the KBR eBus; a maximum of 32 devices per bus segment, up to 1000 m without bus repeater if placed suitably. For additional information, see KBR eBus installation guide.
	Transmission speed	38,400 baud
	Bus protocol	KBR eBus
	KBR eBus address assignment	Can be addressed up to address number 9999, scan mode can be activated on the device
Module bus interface	Serial interface	RS 485 (RJ12) for ready-made KBR system cable (modular cable)
Display and configuration interface	Serial interface	RS485 (RJ12)
Relay outputs	Switching stages	5 relays
	Switching capacity	250V (AC)/2A per relay, potential depending on shared connection
Alarm relay	Switching capacity	250V (AC) / 2A potential-free
1 digital output	S ₀ compatible	max. 35V / 50mA

11.2.7 Mechanical data and dimensioned drawing of the basic module

Top hat rail device	Housing dimensions	90 x 106 x 61 mm (H x W x D)
	Mounting type	Wall mounting on DIN rail 7.5 mm deep, in accordance with DIN EN 50022; suitable for distribution board mounting
	Weight	Approx. 650g

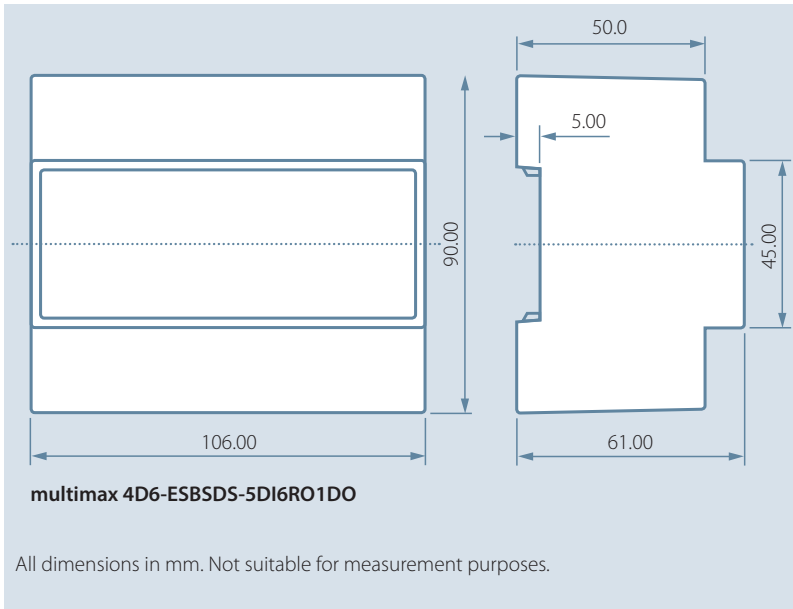

11.2.8 Environmental conditions / electrical safety

Ambient conditions	Standards	DIN EN 60721-3-3/A2: 1997-07; 3K5+3Z11; (IEC721-3-3; 3K5+3Z11)
	Operating temperature	-5°C ... +55°C
	Humidity	5% ... 95%
	Storage temperature	-25°C ... +70°C
Electrical safety	Standards and amendments	DIN EN 61010-1: Aug. 2002 (IEC1010-1/A2)
	Protection class	I, in accordance with DIN EN 61010-/August 2002
	Overvoltage category	CAT III: Relay CAT II
	Protection type	IP20 in accordance with DIN EN 40050 part 9: 1993-05
	Electromagnetic compatibility	DIN EN 61000-6-2: 2000-03; (IEC 61000-6-2) DIN EN 61000-6-3: 2000-03; (IEC 61000-6-3); 2005 - 06

11.2.9 Mechanical data and dimensioned drawing for multimax 4F96-DS display

Power supply:	Via module bus	ext. 24VDC, 1W,
	Connection	Module bus connector RJ12
Serial interface:	Module bus	RS485 via RJ12 interface
	Baud rate	38,400
Module bus connection	Connection material	ready-made KBR system cable (6-pole modular cable, unshielded), max. length 30m if placed suitably

Mechanical Data:		
Switchboard installation	Housing dimensions	96 x 96 x 46 mm (H x W x D)
	Assembly cut-out	92 x 92 mm (according to manufacturer's specifications)
	Protection type	Front IP 51
	Weight	Approx. 175g

Standards and Miscellaneous:		
Ambient conditions:	Standards	DIN EN 60721-3-3/A2: 1997-07; 3K5+3Z11; (IEC721-3-3; 3K5+3Z11)
	Operating temperature	-5°C ... +55°C
	Humidity	5% ... 95%, non-condensing
	Storage temperature	-25°C ... +70°C
Electrical safety	Standards	DIN EN 61010-1/A2: 1996-05; (IEC1010-1/A2)
	Protection type	IP20 in accordance with DIN EN 40050 part 9: 1993-05
	Electromagnetic compatibility	DIN EN 61000-6-3: 2005-06; (IEC 61000-6-3) DIN EN 61000-6-2: 2000-03; (IEC 61000-6-2)

EDEBDA0220-3714-1_EN

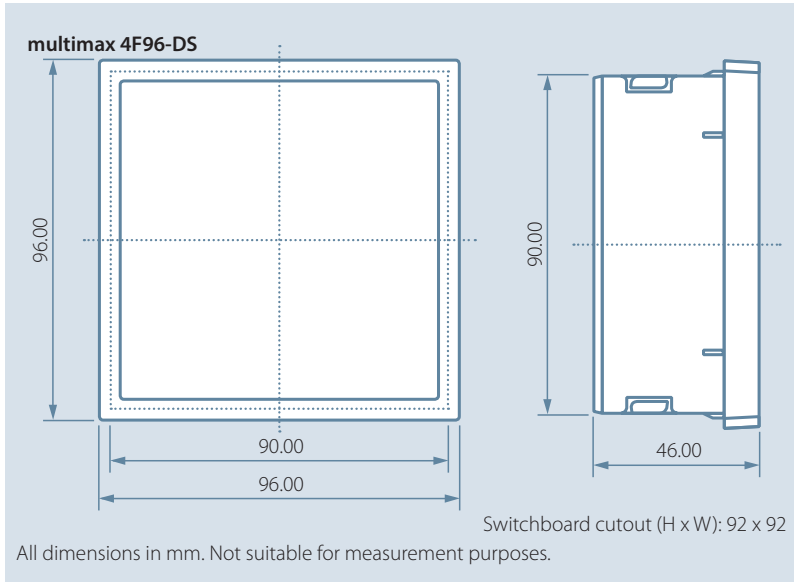

11.2.10 Serial interface

Operating modes and interface configuration RS 485 bus operation

The multimax's RS485 interface is designed for operation on the **KBR eBus**. You can operate one or several multimax 4D6 devices together on the **KBR eBus** across great distances. Typically, the bus is connected to the computer via the **KBR eBus TCP** gateway. Using the relevant Windows® software, all bus devices can be configured and visualized. We will be glad to provide information on which other devices you can connect to the **KBR eBus** as well as on the functionality of our software.

Information on the structure and technical parameters of the **KBR eBus** can be gathered from our installation guide for the **KBR eBus**. Just send a request for this installation guide.

11.2.11 Protective measures – overvoltage and lightning protection

It is recommended to install overvoltage protection measures to protect our high-quality devices from damage. We also recommend to protect control voltage inputs and pulse lines, if required.

12 Connecting additional modules

You can expand your **multimax** with the additional modules **multisio** and **multimes**. You will find a description of the functions of these devices in the following section.

12.1 Function description of the relay output module **multisio 1D4-4RO ISO**

The **multisio 1D4-4RO ISO** hardware supports four floating relay outputs, 5 LEDs and an 8-fold DIP switch.

The relay outputs serve to control contactors of devices or other systems.

The module can be accessed by a basic device (**multimax 3**, **multisio 5D6** or higher, or a computer with **visual energy** via **multisys 3D2-ESBS**) using the module bus interface. The master device has to configure the module.

The operating voltage is supplied via the module bus interface.

12.2 Relay output module connection diagram

Terminal Assignment

- Terminal 40: Input relay 1 (A1)
- Terminal 41: Output relay 1 (A1)
- Terminal 42: Input relay 2 (A2)
- Terminal 43: Output relay 2 (A2)
- Terminal 44: Input relay 3 (A3)
- Terminal 45: Output relay 3 (A3)
- Terminal 46: Input relay 4 (A4)
- Terminal 47: Output relay 4 (A4)

IN/OUT:
Module bus/supply voltage

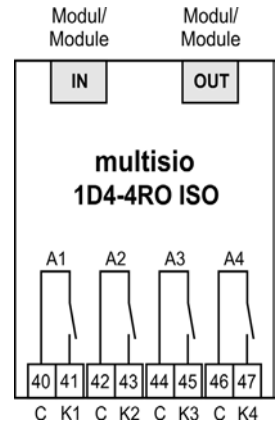

Note

The module relay outputs are designed as floating outputs.

12.3 Relay output module LED display

In KBR module bus scanning mode, all four output LEDs flash. In module detection mode, the output LEDs generate a chase light effect.

The displays are:

LED1 for: Output relay 1 (A1) switched

LED2 for: Output relay 2 (A2) switched

LED3 for: Output relay 3 (A3) switched

LED4 for: Output relay 4 (A4) switched



Power LED: Operating voltage

12.4 Function of the scan button



Note

If the scan button is pressed briefly, the module enters scanning mode.

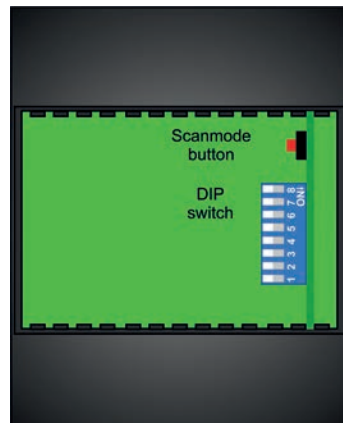

12.5 Function of the DIP switches

Mode of operation:

For every output, the **multisio 1D4-4RO ISO** differentiates between the operating modes “normal” and “manual.” Switching is performed via the DIP switches 5 to 8.

The DIP switches are assigned to the outputs as follows:

- DIP switch 5 determines the operating mode of output 1
- DIP switch 6 determines the operating mode of output 2
- DIP switch 7 determines the operating mode of output 3
- DIP switch 8 determines the operating mode of output 4



If the DIP switch is set to Off, the respective output is in the normal operating mode. If the DIP switch is set to On, the respective output is in the manual operating mode.

Switch setting illustrated:

OFF = white

ON = gray

Normal operating mode

In the normal operating mode, the state created in the module is issued at the corresponding output.

Manual operating mode

In the manual operating mode, the state of DIP switches 1 to 4 is issued at the corresponding output, instead of the state created in the module. The DIP switches are assigned to the outputs as follows:

- DIP switch 1 determines the state of output 1
- DIP switch 2 determines the state of output 2
- DIP switch 3 determines the state of output 3
- DIP switch 4 determines the state of output 4

If the DIP switch is set to **Off**, the output is passive / off. If the DIP switch is set to **On**, the output is active/on.

12.6 DIP switch settings

Mode of operation DIP		State DIP		Explanation
S5	Off	--	--	Output 1 = normal operating mode
	On	S1	Off	Output 1 = manual operating mode passive / off
			On	Output 1 = manual operating mode passive / off
S6	Off	--	--	Output 2 = normal operating mode
	On	S2	Off	Output 2 = manual operating mode passive / off
			On	Output 2 = manual operating mode passive / off
S7	Off	--	--	Output 3 = normal operating mode
	On	S3	Off	Output 3 = manual operating mode passive / off
			On	Output 3 = manual operating mode passive / off
S8	Off	--	--	Output 4 = normal operating mode
	On	S4	Off	Output 4 = manual operating mode passive / off
			On	Output 4 = manual operating mode passive / off

12.7 Function description of the digital input module multisio 2D2-4DI

The **multisio 2D2-4DI** hardware is equipped with four digital inputs.

The module detects an input as active if the input is shorted out. An open switch is detected as passive.

Observe correct polarity when connecting electronic switches.

The four input LEDs indicate the state of the digital inputs and the power LED shows whether an operating voltage is present.

The digital inputs can be used differently, e.g. as state or meter inputs.

The module can be accessed by a master device (**multimax**, **multisio xD6** (from 5D6-ESBS-5DI6RO1DO) with a module bus, multicom with a module bus or via computer with **visual energy via multisys 3D2-ESBS/multisys 3D2-BSES**) using the module bus interface. The master device has to configure the module and read out the data acquired by the module for further processing.

The operating voltage is supplied via the module bus interface.

The module cannot be used on its own.

12.8 Digital input module connection diagram

Terminal Assignment

Terminal 50: Digital input 1 +
 Terminal 51: Digital input 1 -
 Terminal 52: Digital input 2 +
 Terminal 53: Digital input 2 -
 Terminal 54: Digital input 3 +
 Terminal 55: Digital input 3 -
 Terminal 56: Digital input 4 +
 Terminal 57: Digital input 4 -

IN/OUT:

Module bus/supply voltage



12.9 Digital input module LED display

In KBR module bus scanning mode, all four input LEDs flash.

In module detection mode, the input LEDs generate a chase light.

The displays are:

LED1 for input 1
 LED2 for input 2
 LED3 for input 3
 LED4 for input 4

Power LED on:

Operating voltage present

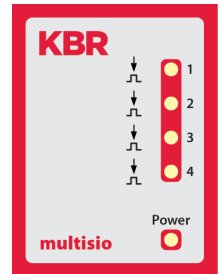

The LEDs on the digital input module indicate the current state of the digital input. If the input is active, the LED is lit. If the input is passive, the LED is off.

12.10 Function of the scan button



Note

If the scan button is pressed briefly, the module enters the scanning mode.

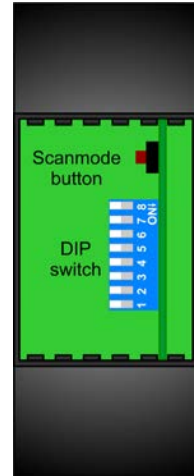

12.11 Function of the DIP switches

Mode of operation:

For every input, the **multisio 2D2-4DI** differentiates between the operating modes "normal" and "manual." Switching is performed via the DIP switches 5 to 8.

The DIP switches are assigned to the inputs as follows:

- DIP switch 5 determines the operating mode of input 1
- DIP switch 6 determines the operating mode of input 2
- DIP switch 7 determines the operating mode of input 3
- DIP switch 8 determines the operating mode of input 4

If the DIP switch is set to Off, the respective input is in normal operating mode. If the DIP switch is set to On, the respective input is in manual operating mode.

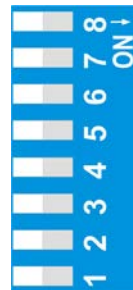

Switch setting illustrated:

OFF = white

ON = gray

Normal operating mode

In manual operating mode, the current state of the respective input is further processed.

Manual operating mode

In manual operating mode, the state of DIP switches 1 to 4 is further processed instead of the state of the relevant input. The DIP switches are assigned to the inputs as follows:

- DIP switch 1 determines the state of input 1
- DIP switch 2 determines the state of input 2
- DIP switch 3 determines the state of input 3
- DIP switch 4 determines the state of input 4

If the DIP switch is set to **Off**, the input state passive/off is further processed. If the DIP switch is set to **On**, the input state active/on is further processed.

12.11 DIP switch settings

Mode of operation		State DIP		Explanation
DIP				
S5	Off	--	--	Input 1 = normal operating mode
	On	S1	Off	Input 1 = manual operating mode passive/off
			On	Input 1 = manual operating mode active/on
S6	Off	--	--	Input 2 = normal operating mode
	On	S2	Off	Input 2 = manual operating mode passive/off
			On	Input 2 = manual operating mode active/on
S7	Off	--	--	Input 3 = normal operating mode
	On	S3	Off	Input 3 = manual operating mode passive/off
			On	Input 3 = manual operating mode active/on
S8	Off	--	--	Input 4 = normal operating mode
	On	S4	Off	Input 4 = manual operating mode passive/off
			On	Input 4 = manual operating mode active/on

12.12 Function description of measuring module multimes 1D4

The multimes 1D4 is a multimeter for DIN rail mounting.

On the output side, it can measure all typical alternating and direct current parameters of devices.



- For busbar assembly (7.5 mm rail)
- Connection to measuring voltage Ph-N 230 VAC
- Measuring-current connection via transformer x/1A or x/5A
- Plug terminal connection 2.5 mm²
- RJ12 module bus connection for supply voltage of the bus interface/
connection of additional measuring modules.
- Recording of current current and voltage values.

Mounting the device

The applicable DIN / VDE regulations must be observed for installation! Before the device is connected to the power supply, check whether the local power supply conditions comply with the specifications on the nameplate. A faulty connection may destroy the system! The device must be connected in accordance with the connection diagram.

Connections	
Terminals 10–13 (L1, L2, L3, N)	Measuring voltage. The power supply of the device is also provided by the measuring voltage. For technical data, please refer to the nameplate.
Terminals 20 (k1) and 21 (i1), 22 (k2) and 23 (i2), 24 (k3) and 25 (i3)	Measuring inputs for current. The measuring inputs for current must be connected via current transformers x/1A AC or x/5A AC. When connecting transformers, pay attention to the current flow direction and the correct assignment of measuring voltage inputs to the current transformers.

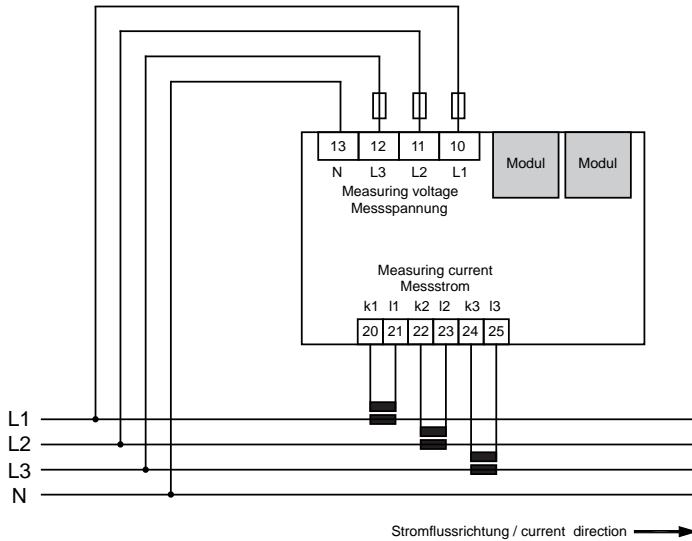

First use of the multimes 1D4 with multimax 4D6

When first using the multimes 1D4 with multimax 4D6, please proceed as follows:

1. Connect the measuring module to the multisys 4D6 via the module bus interface.
2. At the terminals 10 (L1), 11 (L2), 12 (L3) and 13 (N), connect the measuring voltage (the operating voltage of the measuring module).
3. In the multimax 4D6 main menu, select the sub-menu Module management to scan for the connected measuring module.
4. Pre-existing modules are displayed, in addition to the menu item "scan."
5. After selecting the menu item "scan," scan mode is activated and the function LED on the measuring module flashes slowly.
6. At the measuring module, the scan sensor button (close to the status LED, flashing green) is unlocked.



7. To set the measuring module into scan mode, touch the scan sensor button for about 4 seconds (the green status LED flashes more quickly)
8. The multimax 4D6 basic module now recognizes the measuring module and adds it to the list of connected modules.

12.13 Function description of analog input module multisio 2D2-4AI

The multisio 2D2-4AI hardware supports four analog inputs and five LEDs. With its four analog measuring inputs, current values from 0 to 20 mA and voltage values from 0 to 10 V can be measured. The four input LEDs indicate the state of the analog inputs and the power LED shows whether an operating voltage is present. The operating voltage is supplied via the module bus interface

Analog input module connection diagram

IN/OUT: Module bus/supply voltage

Terminal Assignment

- Terminal 70: Analog input 1 +
- Terminal 71: Analog input 1 -
- Terminal 72: Analog input 2 +
- Terminal 73: Analog input 2 -
- Terminal 74: Analog input 3 +
- Terminal 75: Analog input 3 -
- Terminal 76: Analog input 4 +
- Terminal 77: Analog input 4 -

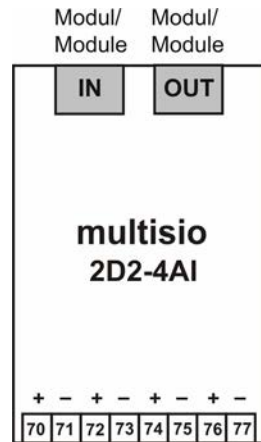

Analog input module LED display

In eBus scanning mode, all four input LEDs flash.

In module detection mode, the input LEDs generate a chase light effect.

The displays are:

- LED1 for input 1
- LED2 for input 2
- LED3 for input 3
- LED4 for input 4

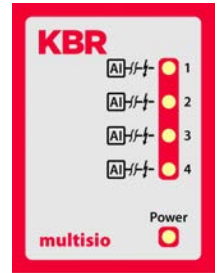

Power LED on: Operating voltage present



Note

For operation on the basic device multimax 4D6, the module always operates at 0–20 mA/0–10 V, meaning the LEDs for inputs 1–4 are always on. The conversion to 4–20 mA/2–10 V is carried out in the basic device.

Function of Scan Button



Note

If the scan button is pressed briefly, the module enters the scanning mode.

Switch setting illustrated = OFF

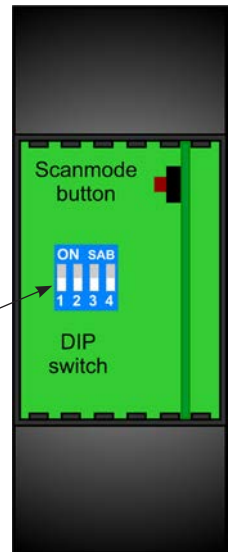

Function of the DIP Switches

Switching of inputs 1 to 4:

In switch position off: In switch position on:

- | | |
|------------------|-------------------|
| S1 = 0 / 2 – 10V | S1 = 0 / 4 – 20mA |
| S2 = 0 / 2 – 10V | S2 = 0 / 4 – 20mA |
| S3 = 0 / 2 – 10V | S3 = 0 / 4 – 20mA |
| S4 = 0 / 2 – 10V | S4 = 0 / 4 – 20mA |

Switch setting illustrated = OFF



12.14 Function description of analog output module multisio 1D2-2AO

The multisio 1D2-2AO hardware supports 2 analog outputs, 5 LEDs, an eightfold DIP switch and a button to start scanning.

LEDs 1 and 2 display the output level of the analog outputs. If the LEDs are on continuously, the output level lies between 80% and 100%. The shorter the “on” time of the LEDs, the lower the output level (if the lengths of the flashes vary, see description of test operation).

At its outputs, the module provides a voltage of 0 to 10 volts or a current of 0 to 20 mA, in accordance with the configuration made via module bus.

For the analog outputs, the following values are given as typical:

Current output: Load max. 400 ohms

Voltage output: Load min. 1,000 ohms

The analog outputs are each connected via a dipolar connector plug. The connectors are marked with “+” and “-” signs. The analog outputs are not electrically isolated from each other.

It is possible to switch between normal and test operation using the DIP switches. The power LED shows whether the operating voltage is present.

Analog Output Module – Connection Diagram

IN/OUT: Module bus/supply voltage

Terminal Assignment

Terminal 60: Analog output 1 +

Terminal 61: Analog output 1 -

Terminal 62: Analog output 2 +

Terminal 63: Analog output 2 -



EDEBDA0220-3714-1_EN

Analog input module LED display

In the KBR eBus scanning mode, all four output LEDs flash. In module detection mode, the output LEDs generate a chase light effect.

The displays are:

LED 1 for output 1 (analog value)

LED 2 for output 2 (analog value)

LED 3 for output 1 (test operation)

LED 4 for output 2 (test operation)

Note: For operation on the basic device multimax 4D6, the module always operates at 0–20 mA/0–10 V, meaning the LEDs for inputs 1–4 are always on. The conversion to 4–20 mA/2–10 V is carried out in the basic device.

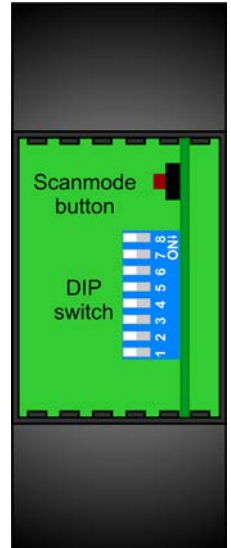
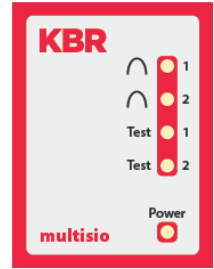

Function of Scan Button



Note

If the scan button is pressed briefly until the LEDs flash quickly, the module enters scanning mode.

Function of the DIP Switches

Normal and Test Operation:

It is possible to switch between normal and test operation using the DIP switches.

OFF ON



Switch setting illustrated = OFF



The individual DIP switches signify the following:

Switch	Off	On
1	Channel 1: normal operation	Channel 1: test operation
2	Channel 1: 0 V to 10 V (in test operation)	Channel 1: 0mA to 20mA (in test operation)
3	Channel 2: normal operation	Channel 2: test operation
4	Channel 2: 0 V to 10 V (in test operation)	Channel 2: 0mA to 20mA (in test operation)

In test operation, DIP switches 5 to 8 indicate the analog value output as a percentage.

Switch	Meaning in Test Operation
5	10% of the analog end value (in test operation, for both channels)
6	20% of the analog end value (in test operation, for both channels)
7	30% of the analog end value (in test operation, for both channels)
8	40% of the analog end value (in test operation, for both channels)

The analog output value and mode of operation should be set first. Only after this should the DIP switch be set to test operation. The output value for this channel will then be saved and output. In this way, it is possible to assign an individual output value to each channel. Changes to the operating mode and value output will be discarded until the normal/test switch is set to test operation.

LEDs 1 and 2 display the analog value of the respective output channels. For this purpose, the LEDs are controlled by flashing. The speed of the flashes shows the analog output value. The flash rhythm is divided into 20% stages. If the LED is on for 20% of the time, the output value is < 20%. If the LED is on continuously, the output value is > 80%. In between, the time during which the LED is on is increased in 20% increments. LED 3 is switched on if output 1 is in test operation. LED 4 indicates the test operation of channel 2.

12.15 Function description of digital output module multisio 2D2-4DO

The multisio 2D2-4DO hardware supports four digital outputs, 5 LEDs and an 8-fold DIP switch.

The module provides digital pulses to its outputs as configured via the module bus.

For each hardware output, a maximum voltage of 35 V is to be applied to the + input. When in the "On" state, the digital output transfers this voltage to the corresponding terminal. To ensure that the current applied does not exceed 50mA, external wiring is necessary. With these parameters, the digital output is compatible with the S0 interface as per DIN 43864.

Observe correct polarity when connecting.

Each output can manually be set to active. If the DIP switch for the channel is set to "OFF," the output state is established within the module. If the DIP switch is set to "ON," the state for this output is kept as active, regardless of the state of the output that has actually been determined.

The LEDs on the digital output module indicate the current state of the digital output. If the output is closed, the LED is lit. If the output is open, the LED is off. A blinking LED indicates that the corresponding digital output has been switched to manual operation.

The operating voltage is supplied via the module bus interface.

Digital output module connection diagram

IN/OUT: Module bus/supply voltage

Terminal Assignment

Terminal 80: Digital output 1 +
 Terminal 81: Digital output 1 -
 Terminal 82: Digital output 2 +
 Terminal 83: Digital output 2 -
 Terminal 84: Digital output 3 +
 Terminal 85: Digital output 3 -
 Terminal 86: Digital output 4 +
 Terminal 87: Digital output 4 -

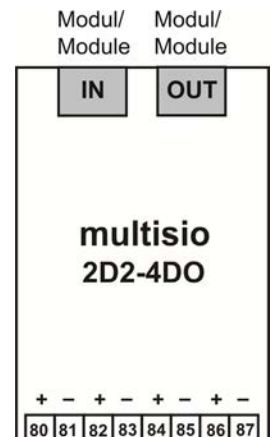

Digital output module LED display

In eBus scanning mode, all four output LEDs flash. In module detection mode, the output LEDs generate a chase light effect. A blinking LED indicates that the corresponding digital output has been switched to manual operation.

The displays are:

LED1 for output 1

LED2 for output 2

LED3 for output 3

LED4 for output 4

Power LED on: Operating voltage present

The LEDs on the digital output module indicate the current state of the digital output. If the output is active, the LED is lit. If the output is passive, the LED is off.

Function of Scan Button



Note

If the scan button is pressed briefly, the module enters the scanning mode.

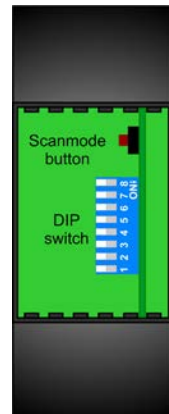
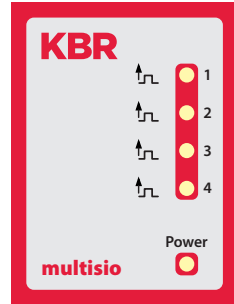

Function of the DIP Switches

Manual operation:

Each output can manually be set to active. If the DIP switch for the channel is set to "OFF," the output state is established within the module. If the DIP switch is set to "ON," the state for this output is kept as active, regardless of the state of the output that has actually been determined.



Switch setting illustrated = OFF

DIP	OFF	ON		
S 8	automatic	address		Output 4
S 7	automatic	address		Output 3
S 6	automatic	address		Output 2
S 5	automatic	address		Output 1
		OFF	ON	
S 4	No function	Passive/off	Active/on	Output 4
S 3	No function	Passive/off	Active/on	Output 3
S 2	No function	Passive/off	Active/on	Output 2
S 1	No function	Passive/off	Active/on	Output 1

Technical Data:

Hardware outputs:		
Four digital outputs	S ₀ -compatible	Max. 35 VDC/50 mA
	8-pole plug terminal	
Display	LED	4x message 1x operation display
Control unit	DIP switch	1x eightfold, output configuration
	Button	Scan button (module bus)



ERKLÄRUNG DER KONFORMITÄT
DECLARATION OF CONFORMITY
DÉCLARATION DE CONFORMITÉ

Wir **KBR GmbH Schwabach**

We/Nous (Name des Anbieters / supplier's name / nom du fournisseur)

Am Kieferschlag 7
D-91126 Schwabach

(Anschiff / address / adresse)

erklären in alleiniger Verantwortung, dass das (die) Produkt(e) /
 declare under our sole responsibility that the product(s) / Déclarons sous notre seule responsabilité, que le(s) produit(s)

multimax 4D6-ESBDS-5DI6RO1DO

(Bezeichnung, Typ oder Modell oder Seriennummer / name, type or model or serial number / nom, type ou modèle, N° de lot ou de série)

mit folgenden Europäischen Richtlinien übereinstimmt (übereinstimmen)
 is (are) in conformity with the following directives / Répond(e)nt aux directives suivantes

Niederspannungsrichtlinie Nr.
 Directive Basse Tension N°

2006/95/EG
 2006/95/EC
 2006/95/CE

EMV-Richtlinie Nr.
 EMV Directive No.
 EMV Directive N°

2004/108/EG
 2004/108/EC
 2004/108/CE

Dies wird nachgewiesen durch die Einhaltung folgender Norm(en)

This is documented by the accordance with the following standard(s) / Justifié par le respect de la (des) norme(s) suivante(s)

DIN EN 61010-1:2001;

DIN EN 61010-1/B1:2002

DIN EN 61010-1/B2:2004

DIN EN 61000-6-1:2007

DIN EN 61000-6-2:2005

DIN EN 61000-6-3:2007

DIN EN 61000-6-4:2007

(Titel und/oder Nr. sowie Ausgabedatum der Norm(en))

Title and/or number and date of issue of the standard(s)

Titre et/ou numéro et date d'édition de la (des) norme(s)

CE

Schwabach, 27.05.2014

(Ort und Datum der Ausstellung)

Place and date of issue

Lieu et date de l'édition

Geschäftsführer
 General manager

KBR GmbH · Am Kieferschlag 7 · D-91126 Schwabach · T +49 (0) 9122 6373-0 · F +49 (0) 9122 6373-83 · E info@kbr.de · www.kbr.de

KBR Kompensationsanlagenbau GmbH

Am Kieferschlag 7
D-91126 Schwabach,
Germany

P +49 (0) 9122 6373-0
F +49 (0) 9122 6373-83
E info@kbr.de

www.kbr.de
www.visualenergy.de